

# Measuring Resistance/Impedance with the Four-Wire Kelvin Method

By JP Martin

To measure the resistance or impedance of a load, multimeters often use a technique known as "constant current." In this method, a source current of constant and known amperage flows across the load under test. The multimeter simultaneously measures the voltage across the load and employs Ohm's Law to calculate the resistance, which in this case results in the formula  $R = V/I$ .

A relatively simple setup for constant current resistance measurement is the two-wire method, also called the two-probe method. This entails connecting two probes to the load under measurement, running a known current through the load and measuring the resulting voltage, and then calculating the resistance. A simplified representation of this setup is shown below:

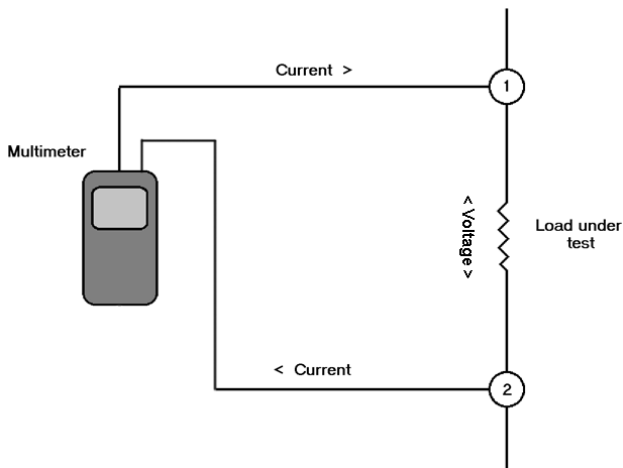

Two-wire setup for measuring resistance/impedance

In the preceding diagram, the probes numbered 1 and 2 provide constant current to the load under test, and also measure the voltage across the load in order to determine the resistance.

The two-wire method works well for moderate-to-high load resistance or impedance. However, for very low load resistances, the resistance inherent in the probe wiring and contacts can contribute a significant percentage to the overall results, making the measurement of the test load resistance inaccurate.

To accommodate this issue, more advanced instruments employ a setup known as the four-wire or Kelvin method. As the name implies, this involves using four probes in an arrangement similar to the example shown below:

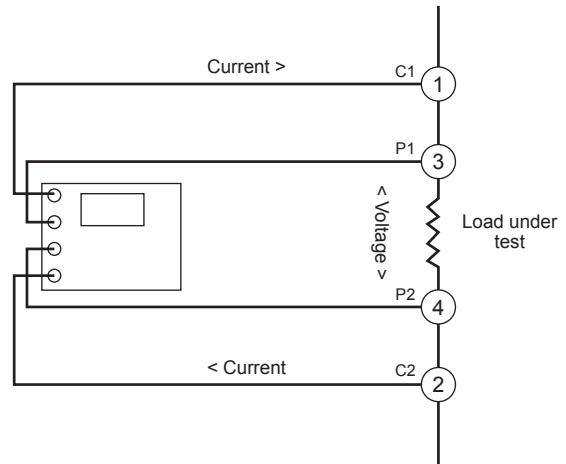

Four-wire (Kelvin) setup for measuring resistance/impedance

In the preceding illustration, two separate pairs of probes are used. Pair 1 and 2 (sometimes referred to as the "source" probes) provides a known quantity of constant current, as in the two-wire setup. In addition, the Kelvin technique employs a second pair of probes (labeled 3 and 4 above) to sense voltage. This second pair is often called the "sense" probes. The placement of these probes ensures that only the voltage across the load is measured, independent of any resistance contributed by the current (source) probes. Virtually no current passes through the sense probes; the current instead passes through the source probes. This allows for a high level of measurement sensitivity and accuracy when the load under test is of low resistance. The ability to accurately measure low resistances can be critical in applications that involve high current, since even a small change in resistance (for example, due to fluctuating temperature) can have a significant effect on voltage levels.

## AEMC Micro-Ohmmeter Model 6292

AEMC® Instruments offers a family of micro-ohmmeters capable of performing four-wire measurements for load resistance and impedance. This includes the recently announced 200A Micro-Ohmmeter **Model 6292**. This instrument is designed for testing EHV circuit-breaker contact resistances, bushing contact joints, welding joints, or any low-resistance measuring application. The Model 6292 can provide high current up to 200A, and is designed to meet the IEEE C57.09-1999 (5.15) requirement for testing circuit breaker contact resistance.

This instrument can precisely measure resistance values from  $1\mu\Omega$  to  $1\Omega$ , with a resolution of  $0.1\mu\Omega$  with current up to 200A<sub>DC</sub> and down to 5A at  $1\Omega$ .

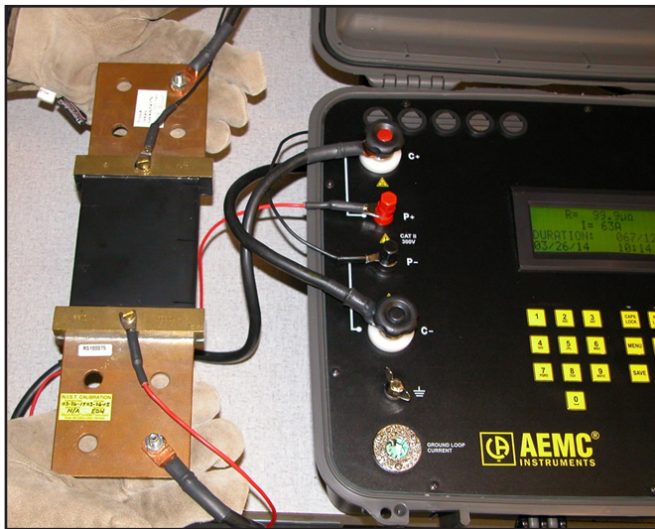

Four-wire Kelvin connection. In this example, an AEMC® 200A Micro-Ohmmeter Model 6292 is measuring the resistance of a test shunt.

Other AEMC® micro-ohmmeter instruments that provide 4-wire testing include:

- **Model 6240:** This is compact and economical 10A micro-ohmmeter designed for applications such as aerospace, telecommunications, automotive, research laboratories, and maintenance departments. This instrument is lightweight (5kg) and can be easily carried into the field or other remote locations.
- **Model 6250:** This 200A micro-ohmmeter is also easily portable, with a very high accuracy and temperature compensation, and can be used in a variety of locations. It offers a wide measurement range ( $0.1\mu\Omega$  to  $2500\Omega$ ) and provides three measurement modes optimized

to suit the application: inductive (small transformers, engines, motors, and so on), non-inductive (contacts, metallization, and others), and automatic non-inductive.

Note that the four-wire method is not suitable for all applications. For example, when the load resistance is high, the resistance in the probes is relatively negligible as a percentage of the overall resistance and therefore does not introduce an unacceptable margin of error. Further, measuring high resistance loads requires that the constant current be kept at very low levels. As a result, ground leakage resistance can become a significant contributor to the overall resistance measurement, in the process rendering the measurement inaccurate.

Note that the Model 6292 mitigates the problem of ground leakage by offering a mode called "Both Sides Grounded" (BSG). Utilities require transformers to employ safety grounds on both sides for safety and expediency testing. In BSG mode, the Model 6292 uses an external DC current probe to measure and eliminate ground leakage current from the total test current, as illustrated in the following diagram:

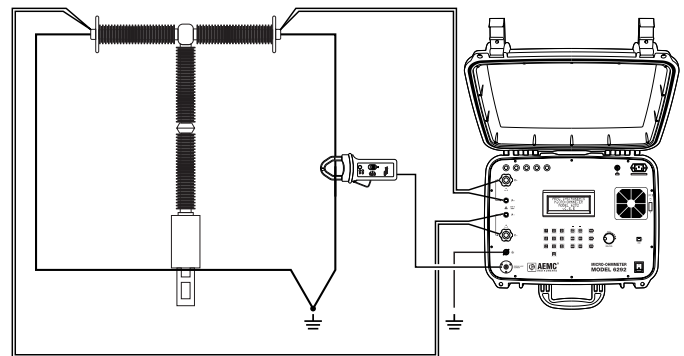

Model 6292 setup for Both Sides Grounded (BSG) testing



About the Author:

JP Martin is the Director of Manufacturing for AEMC® Instruments, Dover NH.