

# RELAYS CATALOG

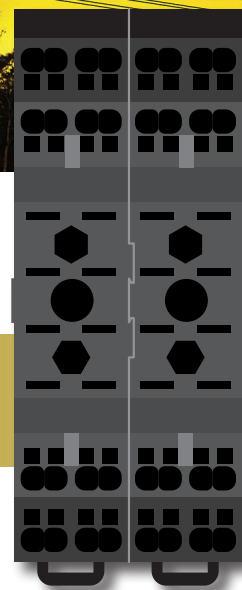

*Measure Up*  
WITH AEMC INSTRUMENTS<sup>®</sup>

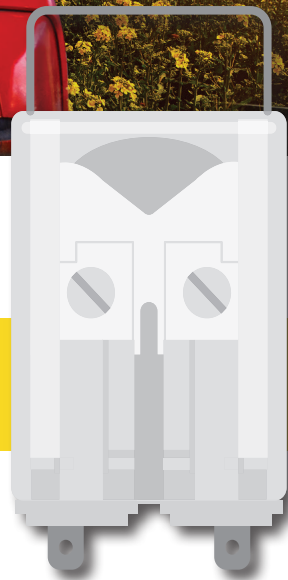

# WHY AEMC® INSTRUMENTS?

## RELAYS & ENERGY MONITORING SOLUTIONS

### OUR STORY

## A CENTURY OF ENGINEERING. A U.S. HOME FOR YOUR TEAM.

When you choose AEMC® Instruments for relay and energy monitoring solutions, you're not choosing a catalog — you're choosing a **relationship built on over 130 years of electrical engineering heritage**, backed by a global group and delivered through a U.S. partner who knows your market, speaks your language, and answers the phone.

AEMC Instruments is the authorized commercial partner for the **Chauvin Arnoux® Group** across North America, South America, and ANZ. Part of a cross-ownership partnership established in 1976, AEMC brings the full weight of European precision manufacturing to customers who need U.S.-based commercial access, application support, and technical service — without navigating an ocean to get it.

The Chauvin Arnoux Group has invested **nearly 11% of annual revenues into R&D every year** — not because they have to, but because it's who they are. That commitment to in-house design and development is what makes this portfolio different from everything else on the market.

**130+**  
YEARS  
HERITAGE

**10**  
SUBSIDIARIES

**11%**  
REVENUE  
IN R&D

### THE ENGINEERING BEHIND THE BRAND

## TWO CA GROUP COMPANIES. ONE PORTFOLIO.

The relay and energy monitoring products available through AEMC are manufactured by two CA Group companies with distinct and complementary expertise — together covering everything from standard automation relays to fully custom solutions for the world's most demanding environments.

### CHAUVIN ARNOUX ENERGY

Manufacturing relays since 1960 and fixed electrical measurement equipment for over six decades. CA Energy is the primary source for the standard relay line, power monitors, energy meters, measurement transducers, panel meters, and current sensors in this catalog. Built in France. Backed by a global quality system.

### AMRA S.P.A. — MILAN, ITALY

The CA Group's specialist for custom relay engineering. Building electromechanical relays since 1975, AMRA's portfolio is approved and certified by major operators across rail, nuclear, naval, and industrial sectors worldwide — including Paris Metro's fully automated Line 14.

Together, they bring you a relay portfolio with **over 200 references**, built across **3 manufacturing sites** and validated by **20+ years of K3 nuclear qualification** — offered through AEMC with full U.S. commercial and technical support.

**"Global engineering strength. U.S. accountability. One partner for the life of your installation."**

<b>WHAT WE BUILD</b> .....	P. 2
<b>FROM SUBSTATION TO STATION — AEMC® INSTRUMENTS FOR RAIL APPLICATIONS</b> .....	P. 4
<b>MAIN PARAMETERS FOR DEFINING ELECTROMECHANICAL RELAYS</b> .....	P. 6
<b>MAIN FEATURES OF OUR RELAYS</b> .....	P. 8
<b>SELECTION GUIDE — RELAYS</b> .....	P. 9
<b>SELECTION GUIDE — SOCKETS</b> .....	P. 12
<b>ORDERING SCHEME</b> .....	P. 13
<b>RELAYS</b> .....	P. 14
<b>INSTANTANEOUS MONOSTABLE RELAYS</b> .....	P. 16
POK SERIES .....	P. 18
OK SERIES .....	P. 20
F-OK B SERIES .....	P. 28
<b>INSTANTANEOUS MONOSTABLE RELAYS WITH FORCIBLY GUIDED CONTACTS</b> .....	P. 38
RCG / RDG SERIES .....	P. 42
RGG SERIES .....	P. 44
RMGX SERIES .....	P. 50
<b>TIME DELAY RELAYS (ON PICK-UP OR DROP-OUT), LOGIC FUNCTION</b> .....	P. 56
TMM SERIES .....	P. 62
TM SERIES .....	P. 64
TOK SERIES .....	P. 74
<b>SOCKETS</b> .....	P. 82
<b>EXPLANATION OF SOCKET NUMBERING</b> .....	P. 88
<b>SOCKETS WITH FRONT CONNECTION</b> .....	P. 90
SOCKETS WITH FRONT CONNECTION / SPRING CLAMP TERMINALS .....	P. 92
SOCKETS WITH FRONT CONNECTION / SCREW TERMINALS .....	P. 94
<b>SOCKETS WITH REAR CONNECTION</b> .....	P. 98
SOCKETS WITH REAR CONNECTION / SPRING CLAMP TERMINALS .....	P. 98
SOCKETS WITH REAR CONNECTION / SCREW TERMINALS .....	P. 102
SOCKETS WITH SINGLE FASTON REAR CONNECTION .....	P. 103
SOCKETS WITH DOUBLE FASTON REAR CONNECTION .....	P. 105
<b>MOUNTING ON PCB</b> .....	P. 108
<b>RETAINING CLIPS</b> .....	P. 110
<b>KEYING PINS</b> .....	P. 114
<b>INSTALLATION, OPERATION AND MAINTENANCE</b> .....	P. 118

# WHAT WE BUILD

Purpose-built for critical electrical infrastructure — from standard automation relays to fully custom solutions for the harshest environments on earth.

## 01 • AUTOMATION RELAYS

### WHERE FAILURE IS NOT AN OPTION

Standard and custom electromechanical relays for the world's most demanding environments. **Over 200 references**, manufactured by CA Energy and AMRA S.p.A. — a combined relay engineering legacy stretching back to 1960.

- Instantaneous monostable relays
- Time-delay relays (pick-up / drop-out)
- Function & logic relays
- Connectors, sockets & accessories
- Custom relay engineering (AMRA)

## 02 • POWER & ENERGY MONITORING

### MEASURES. MONITOR. MANAGE.

Fixed electrical measurement and monitoring for LV, MV, and HV networks. **Built for continuity of service** in power generation, T&D, industrial environments, and rail, where uptime is non-negotiable.

- Power monitors (LV / MV / HV)
- Power quality analyzers
- Energy meters (IEC/MID submeters)
- Tariff meters & multi-channel metering
- Monitoring networks & communications

## 03 • FIXED MEASUREMENT & CONTROL

### THE SIGNALS YOUR SYSTEM DEPENDS ON

Precision fixed-installation measurement for demanding switchboard, industrial, and infrastructure applications. **IEC-compatible**, modular, built to outlast the installation.

- Analog & digital transducers
- Analog & digital panel meters
- Hour meters
- Current transformers (standard & tariff)
- Measurement shunts

## FIELD-PROVEN REFERENCES

**RATP and SNCF:** Trusted by **Paris Metro** (including fully automated Line 14) and **French National Rail**.

**Mexico City Metro:** 16 train models (rubber-tired and steel wheel). **CRRC (China Railway Rolling Stock Corporation):** The world's largest supplier of rail transit equipment. **Projects include:** Xi'an, Jiaying, Harbin, Wuhan, Taiyuan metro lines; Jinyi-Dong Urban Rail Project, Brazil Vale Mainline Railway Passenger Train Project, CR450 High-Speed Train Project, etc.



## KEY CERTIFICATIONS

EN 61810-3A

### Forced-Guided Contacts

Weld-no-transfer. Gold standard for SIL-rated and safety-critical relay systems.

SIL-4 · IEC 61508

### Highest Functional Safety Level

Our relays support fully automated and driverless transit requirements.

K3 · 20+ Yrs

### Nuclear Qualification

Continuous qualification for safety-critical environments.

ISO 9001/14001

### Quality & Environmental

Design, manufacturing, and sales — fully certified.

EN 45545-2

### Railway Fire Behavior

Required for all modern rolling stock applications.

EN 61373

### Shock & Vibration

All AMRA rail relays tested and certified to this standard.

RFI Approval

### Italian National Rail

Internationally recognized quality and performance benchmark.

## APPLICATION SECTORS

Validated across sectors where performance is non-negotiable. Highlighted sectors reflect active certifications and field references.

RAIL & ROLLING STOCK

NUCLEAR

POWER GENERATION

NAVAL & DEFENSE

INDUSTRIAL AUTOMATION

T&D INFRASTRUCTURE

RENEWABLES

OIL & GAS

SWITCHBOARD & MCC

BUILDING & FACILITY

Highlighted (yellow) = active certifications and field references. All sectors supported through AEMC application engineering.

# MORE THAN A SUPPLIER. A PARTNER FOR THE LONG GAME.

From the first specification conversation to the last install call — and every application challenge in between.

## 01 • SPECIFICATION SUPPORT

### THE RIGHT RELAY. THE FIRST TIME.

AEMC provides access to a **joint U.S. and European technical team** — engineers who understand your environment, compliance requirements, and certifications before the order is placed.

- Application engineering consultation
- Certification & compliance guidance
- SIL / functional safety scoping
- Custom relay definition via AMRA
- Joint U.S. + European technical support

## 02 • PRODUCT AVAILABILITY

### BUILT TO LAST. AVAILABLE TO MATCH.

Relay infrastructure isn't replaced on a product cycle — it's maintained for decades. CA Energy and AMRA engineer for **long-term product availability**, with integrated in-house manufacturing from design through final testing ensuring supply chain stability you can plan around.

- Long lifecycle product commitments
- Integrated design-to-production control
- In-house manufacturing — 3 global sites
- Custom configurations via AMRA
- OEM solutions available on request

## 03 • SERVICE & SUPPORT

### SUPPORT THAT DOESN'T STOP AT DELIVERY.

When something needs attention in the field, AEMC's U.S.-based team is ready.

**Direct access to technical support, repair consultations, and commercial assistance** — no overseas time zones, no language barriers, no runaround.

- U.S. technical support hotline
- Repair consults for field failures
- Coast-to-coast District Sales Engineers
- Worldwide distributor network
- Direct access: (800) 343-1391 x543

## STEP 01

### SPECIFY

Application engineers identify the right solution before a single unit ships.

## STEP 02

### IMPLEMENT

Technical support and documentation keep your installation on track from day one.

## STEP 03

### SUSTAIN

Repair services and ongoing field support keep systems performing for the life of the installation.

## BUILT FOR WHAT'S NEXT

**Renewable energy, EV infrastructure, microgrids, and smart grid communications** are creating new demands on relay performance and monitoring precision across every sector we serve.

The CA Group's R&D investment — nearly 11% of annual revenues — means this portfolio evolves with the grid. AEMC ensures North American customers access those innovations as they happen, not years later.

RENEWABLES

SMART GRID

MICROGRIDS

EV INFRASTRUCTURE

IEC COMMS

MODULAR MONITORING

## THE VALUE EQUATION

European-engineered performance at a competitive North American price point — with **higher margin percentages than many comparable product categories**. A win for end-users and distribution partners alike.

Custom OEM solutions, long product availability cycles, and integrated manufacturing from design through final testing — total cost of ownership made clear.

### OEM Solutions Available

Custom relay configurations engineered to your exact requirements. Contact AEMC to discuss your application.

Ready to specify the **right solution?** Let's talk.

Technical Hotline (800) 343-1391 x543  
Sales [sales@aemc.com](mailto:sales@aemc.com)

# FROM SUBSTATION TO STATION: AEMC® INSTRUMENTS FOR RAIL

## PORTABLE MEASURING INSTRUMENTS

**1**  **GROUND RESISTIVITY MEASUREMENTS**

- Programmable ground clamp: ground loop testing and leakage current measurement.
- MODEL 6416**

**2**  **Earth and resistivity tester:** comprehensive grounding surveys.

**MODEL 6471**

**3**  **INSULATION MEASUREMENTS**

- Digital megohmmeters: insulation testing on electrical installations and equipment.
- MEGOHMMETER**
- MODEL 5070**

**4**  **Expert insulation tester up to 15 kV.**

**MEGOHMMETER**

**MODEL 6555**

**5**  **CURRENT MEASUREMENT**

- Digital TRMS ammeter with flexible sensor.
- DIGITAL FLEXPROBE® MINIFLEX®**
- MODEL 4000D**

**6**  **POWER & ENERGY QUALITY**

- Industrial electrical network analyzer: For electrical maintenance of power supply installations and buildings.
- POWERPAD® IV - CLASS A**
- MODEL 8435**

**7**  **CONTINUITY**

- 10 A micro-ohmmeter: detection of deterioration between 2 contacts.
- MICRO-OHMMETER**
- MODEL 6255**

**8**  **ELECTRICAL MEASUREMENTS**

- TRMS digital multimeter: portable instrument for maintenance applications.
- DIGITAL MULTIMETER**
- MODEL MTX 3292B**

**9**  **ENVIRONMENTAL MEASUREMENTS**

- Air quality measurement in a confined environment (CO<sub>2</sub>, humidity, temperature) with parameterized compliance thresholds
- LIGHTMETER DATA LOGGER**
- MODEL 1110**

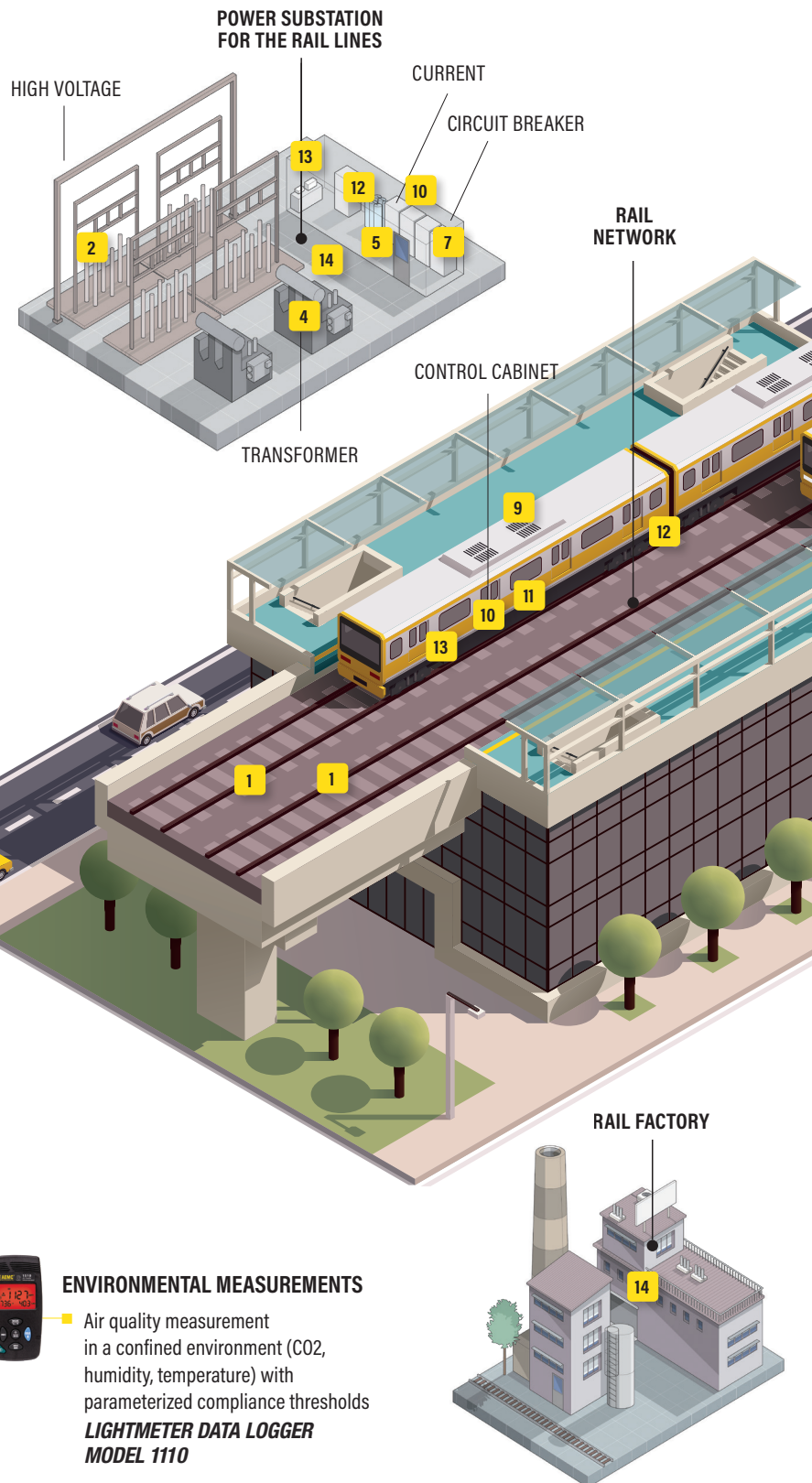

Rail has been part of the Chauvin Arnoux Group's DNA from the beginning — and AEMC Instruments brings that expertise directly to North American rail operators, engineers, and specifiers. Our portfolio spans rolling stock, infrastructure, substations, and power supply installations, with solutions engineered to meet the evolving demands of modern rail networks and the international standards they operate under.

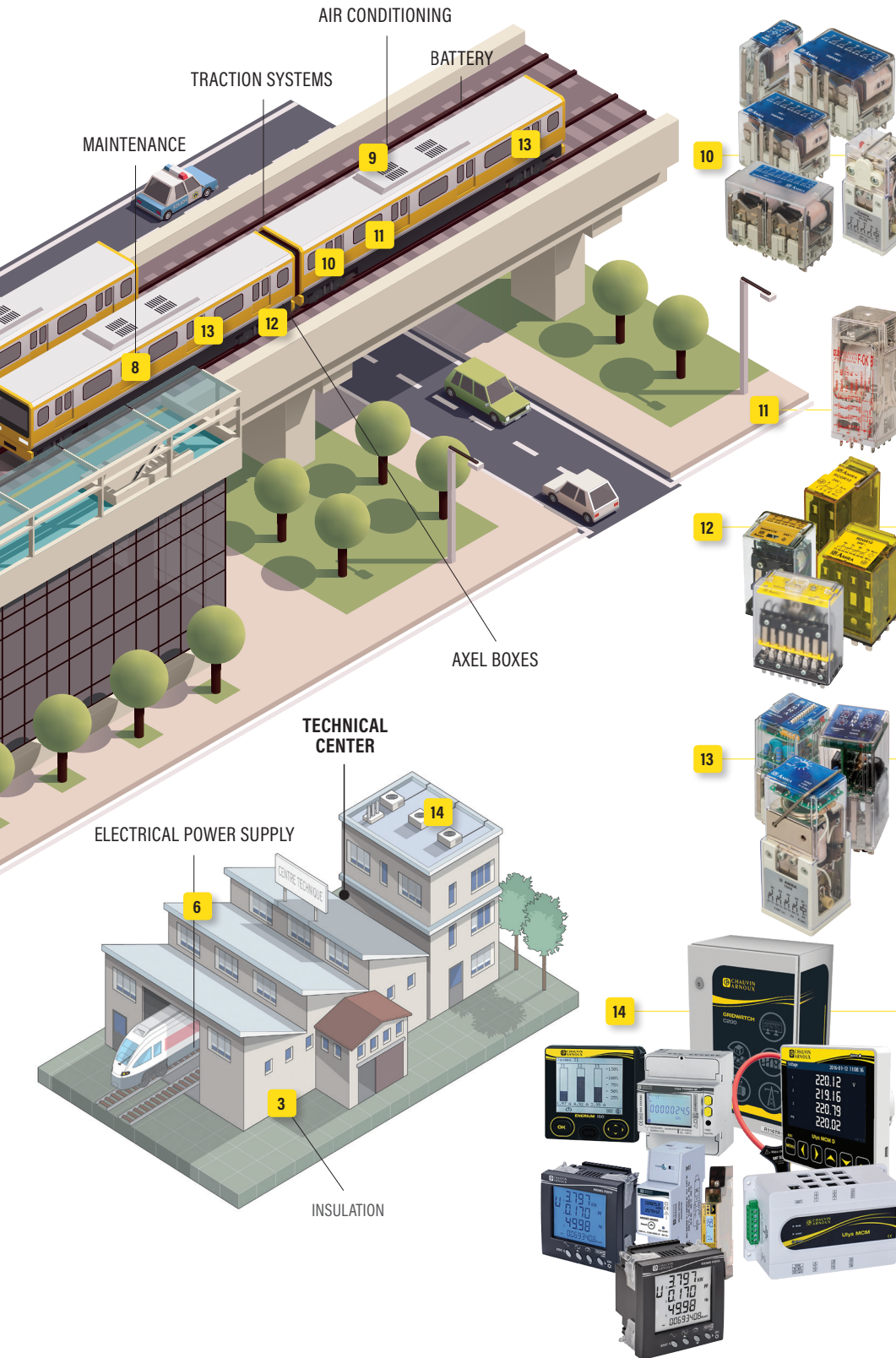

## FIXED MEASUREMENT EQUIPMENT

### AUTOMATION RELAYS

- **Monostable safety relays and timers:** control of the electrical command systems on board railway rolling stock.

**COMPACT PLUG-IN MODELS:** POK, BIPOK, TRIPOK, QUADRIPOK & ESAPOK

(2-4-6-8 and 12 CHANGE OVER CONTACTS)

**PLUG-IN MODELS:** OK, OKS, OKFC, OKSFC, OKScd, OKSGcCd, OKUIC, OKB184

(4, 8 and 12 change over contacts)

- **Double-break monostable relay:** command-control of electrical systems.

**MODELS:** F-OK B

(4 double-break changeover contacts)

- **Monostable relays with forcibly guided contacts (Mechanically linked):** control safety circuits where mechanically guaranteed contact states ensure fail-safe operation.

**MODELS:** RCG, RDG (2-4 forcibly guided contacts); RGG (4 forcibly guided contacts),

RMGX (6 CO + 2 NO forcibly guided contacts)

### TIME DELAY RELAYS

- **Multifunction multiscale timer delay relays:** delay or sequence the switching of electrical circuits by a preset time interval

**MODELS:** TMM (multifunction, 10 programmable delay functions, 4 contacts)

TM (Time delay on pick-up or drop-out, 4 contacts),

TOK (Time delay on pick-up or drop-out, high breaking capacity, 4 contacts)

### ENERGY MANAGEMENT

- **Meter and power monitor:** monitoring and remote retrieval of electrical energy consumption data.

**MODELS:** ENERIUM SERIES (power monitors),

MEMO P200 (simpler power monitor), ULYS

SERIES (advanced Iv energy meters), ULYS

MCM MULTI-CHANNEL METER (MCM9,

MCM18 centralizes measurement up to 18

feeders), GRIDWATCH (c50 and c200 – remote monitoring for multi-site data retrieval)

# APPLICATIONS

Marketed under the **CHAUVIN ARNOUX** brand, our products have become essential in the most demanding applications and sectors, mainly in electrical power generation, transmission and distribution, the petrochemical and mining industries, commercial shipbuilding and the rail industry (rolling stock and infrastructure). All these applications share a common requirement: continuity of service. A shutdown of the system may often cause serious inconvenience for the public and additional costs for the industrial company, as well as damaging its image. Working as a designer means choosing components whose reliability and durability are proven, with a high operational responsibility.

## POWER GENERATION, TRANSMISSION AND DISTRIBUTION



- Protection, control and monitoring systems for HV distribution stations
- Protection, control and monitoring systems for electrical power generation stations
- Automation systems for turbines, alternators and transformers
- Monitoring and control systems for reservoirs, dams and valves/sluices
- Trip relays



## PETROCHEMICALS AND CHEMICALS INDUSTRIES, SHIPBUILDING, HEAVY INDUSTRY



- Protection, control and monitoring systems for power transformation and conversion
- Instrumentation desks and automation of manufacturing processes
- MV load centers
- Electrical switchboards in motor control centers (MCC)





Use the symbol of the application to identify the right product more easily.

## ROLLING STOCK



- Door control
- Brake systems
- Safety loops
- Pantograph control
- Lighting and air-conditioning control
- Battery charge monitoring
- Traction systems
- Vehicle safe-running control systems (ECO, MS, SCMT, ATS, etc.)



## POWER SYSTEMS, AC/DC CONVERSION AND ELECTRIC RAIL TRACTION



- Protection, control and monitoring systems for AC/DC conversion stations
- Line disconnect control panels
- Supervision of line voltage presence
- PPF power supply systems
- Trip relays
- Railway signaling power supply systems



# MAIN PARAMETERS FOR DEFINING ELECTROMECHANICAL RELAYS

## TYPES OF RELAYS

Electromechanical relays can offer several functions:

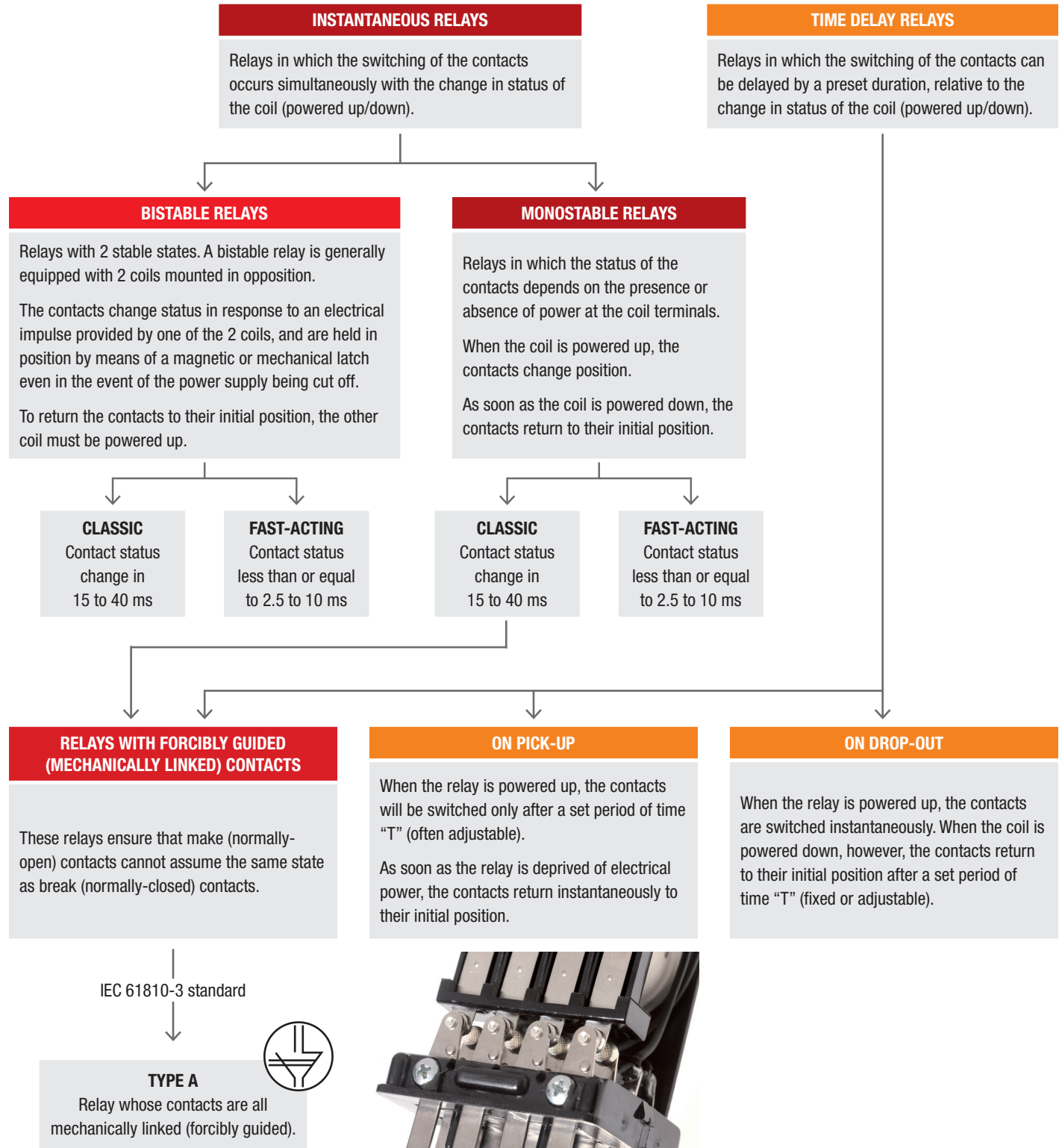

# MAIN FEATURES OF OUR RELAYS

INSTANTANEOUS  
MONOSTABLE

INSTANTANEOUS  
MONOSTABLE WITH  
FORCIBLY GUIDED CONTACTS

TIME DELAY  
(ON PICK-UP  
OR DROP-OUT)

EXPLANATION OF  
SOCKET NUMBERING

FRONT  
CONNECTION

BACK  
CONNECTION

PCB MOUNT

RETAINING CLIPS

KEYING PINS

## COIL SUPPLY VOLTAGE

The power supply used by relays is characterized by a number of factors, and principally:

**NOMINAL VOLTAGE ( $U_n$ ):** voltage value which is sufficient to actuate the contacts

**OPERATING RANGE:** the voltage range within which the relay functions correctly, expressed usually as a percentage of the nominal voltage

**CONSUMPTION:** power drawn by the relay during operation

**DROP-OUT VOLTAGE:** standard value (expressed as percentage of nominal voltage) defining the voltage at which drop-out/de-energization of the relay is certain to occur.

Some applications require particularly wide operating ranges, for example 0.7 to 1.25  $U_n$  in the case of electromechanical components used on rolling stock.

## PROTECTION DEVICES

On a relay, when the power supply is discontinued, energy stored in the coil inductance creates an electromotive force contrary to that of the power supply. This stray voltage can reach values measured in thousands of volts. In this situation it is possible to install voltage suppression components, such as **FLYBACK DIODES**, **VARISTORS** or **TRANSIL DIODES**.

### FLYBACK DIODE

The most widely adopted suppression component. This component provides a very low recirculation resistance for the energy accumulated at the terminals of the coil.

### DIODE TRANSIL

#### UNIDIRECTIONAL TRANSILS

These block disturbances in one direction only, whereas in the presence of voltages with opposite polarity they respond as normal diodes.

#### BIDIRECTIONAL TRANSILS

These are installed in circuits where an alternating voltage is present; they consist of two Transil diodes connected in anti-series.

### VARISTOR

A variable resistor (non-polarized), whose resistance value depends on the applied voltage.

# MAIN FEATURES OF OUR RELAYS

## CONTACT

### TYPE

#### FORM C

This operates on the principle of **Break Before Make** (BBM). When the coil is energized, the COM (common) pole first breaks electrical continuity with the NC (normally closed) pole, then establishes electrical continuity with the NO (normally open) pole. Versions available with 2 to 20 contacts.

#### FORM D

This operates on the principle of **Make Before Break** (MBB).

### SYMBOL DEFINITION



Normally open (Make)



Normally closed (Break)



Changeover (CO)

### CONTACT LOAD

Depending on the type of load circuit to be broken, contacts can be specified with different materials or finishes, and mounted in conjunction with a magnetic blow-out function that helps to extinguish the electric arc generated by the electrical load to which the relay is connected. It is important to take note of the difference between the nominal current (range) of the contact and its **breaking capacity**:

- **NOMINAL CURRENT:** The current that can flow through a contact for an indefinite period of time without the contact suffering damage.
- **THE BREAKING CAPACITY:** Depending on its specific attributes, the relay can break high or low power loads. The breaking capacity, expressed in amperes, is the maximum level of current that can be broken by the particular relay under specific conditions.

By determining these parameters, it is possible to establish the electrical life expectancy of the contact/relay. The contacts of relays are subject to wear; depending on the type of use envisaged, the manufacturer indicates an electrical life expectancy and a mechanical life expectancy.

### LIFE EXPECTANCY

#### ELECTRICAL

The number of successful operations that can be accomplished by a contact, breaking or making a given load circuit at a selected hourly frequency, with no impairment of its electrical specifications.

#### MECHANICAL

The number of successful operations that can be accomplished by a contact under no-load conditions (no electrical load) at a selected hourly frequency, with no impairment of specifications designed to ensure correct operation of the relay.

### PROTECTION

#### MAGNETIC ARC BLOW-OUT

Permanent magnet allowing an electric arc to be extinguished more quickly, thus increasing the breaking capacity.

#### GOLD-PLATING OF THE CONTACTS

This has the effect of lowering surface resistance and enabling the conduction of lower currents than would be possible with an untreated contact.



*POK relay with gold-plated contacts and terminals plus tropicalized coil.*

# MAIN FEATURES OF OUR RELAYS

## CONTACT

### ENVIRONMENTAL AND OPERATING CONSTRAINTS

To ensure that you choose the right relay for a given application, any environmental constraint must first be interpreted correctly. Depending on the application for which it has been chosen, any relay may be exposed to diverse environmental constraints which may prevent correct operation and accelerate its deterioration if it is incorrectly assessed. The following factors need to be taken into consideration for correct analysis:

<b>OPERATING TEMPERATURE RANGE</b>	The ambient temperature at which the relay is required to operate. In the event of conditions being variable, worst case minimum and maximum values must be considered.
<b>RELATIVE HUMIDITY</b>	Percentage value indicating the level of ambient humidity; for values higher than 75 % and up to 95 %, selection of a relay with tropicalized coil is advisable.

### RAIL, TRAM, TROLLEY AND METRO

In the case of transport applications (rail, tram, and metro), consideration must be given to the regulations governing this sector, with specify more stringent operating constraints than those of standard product regulations.

Harmonized European and extra-European standards tend to regulate the following parameters:

<b>RESISTANCE TO SHOCK AND VIBRATION</b>	These can damage the component or cause contacts to open spontaneously.
<b>REACTION TO FIRE</b>	The specified requirements are intended to protect passengers and crew in the event of fire breaking out on board.
<b>OPERATING RANGE</b>	The operating range is wider than indicated normally for standard electromechanical components, as relays can also be battery-powered.
<b>OPERATING TEMPERATURE</b>	In rolling stock, the temperature range will usually be wider than the range indicated for industrial applications.

### ELECTRICAL POWER GENERATION

Electricity generating stations are complex environments. The loads supervised by control systems often use DC voltages, so the relay contacts must be suitable for switching these loads.

Nuclear, thermoelectric, hydroelectric and wind power installations are also required to withstand heavy duty, non-stop operating conditions. They impose particularly stringent requirements in terms of guaranteeing continuity of service and long-term reliability. In the case of hydroelectric and wind power generating facilities located in places where access is difficult (mountains or offshore platforms), maintenance costs tend to be high.

Particular care must also be taken where there are significant variations in temperature and vibration for these applications.

<b>K3 QUALIFICATION</b>	Category K3 (seismic stresses) corresponds to EDF qualification for use of our products in nuclear power plants.
-------------------------	--

INSTANTANEOUS  
MONOSTABLE

INSTANTANEOUS  
MONOSTABLE WITH  
FORCIBLY GUIDED CONTACTS

TIME DELAY  
(ON PICK-UP  
OR DROP-OUT)

EXPLANATION OF  
SOCKET NUMBERING

FRONT  
CONNECTION

BACK  
CONNECTION

PCB MOUNT

RETAINING CLIPS

KEYING PINS

# SELECTION GUIDE - RELAYS

 Power generation	 Nuclear	 Power transmission	 Rolling stock	 Fixed railway installation	 Shipbuilding	 Petroleum industry	 Heavy industry
---	--	---	--	---	---	---	---





Depending on products



Model	Monostable instantaneous	Forcibly guided contacts	Time delay	Contacts	In	Notes	Rolling stock equipment (*)	Nuclear	Page
POK - POKS	■			2 CO	5-10 A	Compact			18
BIPOK - BIPOKS	■			4 CO	5-10 A	Compact			18
TRIPOK - TRIPOKS	■			6 CO	5-10 A	Compact			18
QUADRIPOK	■			8 CO	10 A	Compact			18
ESAPOK	■			12 CO	10 A	Compact			18
OK	■			4-8-12 CO	10 A	High breaking capacity			26
OKB184	■			4 CO	10 A	High breaking capacity, K3-qualified			26
F-OK B	■			4 CO NC-NO	13 A	High breaking capacity, NF F62-002			36
RCG	■	■		2 CO	10 A	Forcibly guided contacts, type A, EN 61810-3			42
RDG	■	■		4 CO	10 A	Forcibly guided contacts, type A, EN 61810-3			42
RGG Previous name RGMZX	■	■		4 CO	10 A	High breaking capacity, forcibly guided contacts, type A, EN 61810-3			48
RMGX	■	■		8 CO	10 A	High breaking capacity, forcibly guided contacts, type A, EN 61810-3			54
TMM			■	4 CO	10 A	Multifunction relay, 10 functions			62
TM - TMS Previous names OK-TMF/S			■	4 CO	5-10 A	Time delay on pick-up or drop-out			72
TOK			■	4 CO	10 A	High breaking capacity, time delay on pick-up or drop-out			80

\* These relays comply with regulations applicable to rolling stock; **also suitable for use in other applications.**

# SELECTION GUIDE - SOCKETS

TERMINAL	FRONT Connection			REAR Connection			PCB
	SCREW		SPRING CLAMP	SCREW	DOUBLE FASTON	SPRING CLAMP	
MOUNTING	PLATE-WALL / DIN RAIL	PLATE-WALL	PLATE-WALL / DIN RAIL	FLUSH MOUNTING			SOLDER
 RELAY MODEL	 SOCKET MODEL						
<b>POK - POKS</b>	50IP20-I DIN	50L	PAIR080	53IL	ADF1	PRIR080	65
<b>BIPOK - BIPOKS</b>	48BIP20-I DIN	48BL	PAIR160	43IL	ADF2	PRIR160	65
<b>TRIPOK - TRIPOKS</b>	78BIP20-I DIN	78BL	PAIR240	73IL	ADF3	PRIR240	-
<b>QUADRIPOK</b>	96IP20-I DIN	96BL	PAIR320	43IL	ADF4	PRIR320	65
<b>ESAPOK</b>	156IP20-I DIN	78BL	PAIR480	73IL	ADF6	PRIR480	-
<b>OK / OKB184</b>	48BIP20-I DIN	48BL	PAIR160	43IL	ADF2	-	65
<b>F-OK B</b>	-	-	-	-	84F*	-	-
<b>RCG</b>	50IP20-I DIN	-	PAIR080	-	ADF1	PRIR080	65
<b>RDG</b>	48BIP20-I DIN	-	PAIR160	-	ADF2-BIPOK	PRIR160	65
<b>RGG</b>	48BIP20-I DIN	-	PAIR160	43IL	ADF2	PRIR160	65
<b>RMGX</b>	96IP20-I DIN	-	PAIR320	-	ADF4-E1	PRIR321	-
<b>TMM</b>	48BIP20-I DIN	48BL	PAIR160	43IL	ADF2	PRIR160	65
<b>TM - TMS</b>	48BIP20-I DIN	48BL	PAIR160	43IL	ADF2	PRIR160	65
<b>TOK</b>	48BIP20-I DIN	48BL	PAIR160	43IL	ADF2	PRIR160	65

OLD SOCKET NAME	NEW SOCKET NAME
50	50IP20-I DIN
48B	48IP20-I DIN
78B	78IP20-I DIN
50BF	50L
48BF	48BL
78BF	78BL
65F	65

\*84F: Single Faston

For more details, please see the socket datasheets.



# ORDERING SCHEME

The product code is obtainable from the “Ordering scheme” table indicated in the data sheets for each product.

Codes to order									
		1	2	3	4		5	6	7
Model	Number of CO contacts	Product code	Application	Configuration A	Configuration B	Label	Type of power supply	Nominal voltage (V)	Keying position / option
POK	2 - 5 A	POK	<b>E:</b> Energy Railway Fixed Equipment  <b>R:</b> Railway Rolling Stock	1: Standard	0: Standard	F	C: V <sub>DC</sub> A: V <sub>AC</sub> 50 Hz H: V <sub>AC</sub> 60 Hz	012 - 024 - 036 048 - 072 - 096 100 - 110 - 125 127 - 132 - 144 220 - 230	XXX <b>CS</b> = PCB-mount version  <b>L</b> = low temperature
POKS	2 - 10 A	POKS		2: Diode //	2: P2				
BIPOK	4 - 5 A	BPOK		3: Varistor	4: P4 GEO				
BIPOKS	4 - 10 A	BPOKS		4: LED	5: P5 GEO				
TRIPOK	6 - 5 A	TPOK		5: Diode // + LED	6: P6 GEO				
TRIPOKS	6 - 10 A	TPOKS		6: Varistor + LED	7: P7				
QUADRIPOKS	8 - 10 A	QPOK		7: Transil	8: P8				
ESAPOKS	12 - 10 A	EPOK		8: Transil + LED					

Example	<b>TPOKS</b>	<b>E</b>	<b>3</b>	<b>0</b>	<b>F</b>	<b>A</b>	<b>230</b>	
	TPOKSE30F-A230 - TRIPOKS relay, ENERGY series, nominal voltage 230 V <sub>AC</sub> , equipped with varistor							
	<b>POK</b>	<b>R</b>	<b>1</b>	<b>0</b>	<b>F</b>	<b>C</b>	<b>110</b>	<b>L</b>
POKR10F - C110 L - POK relay, rolling stock series, nominal voltage 110 V <sub>DC</sub> with option “L” (low temp.)								

<b>1 PRODUCT CODE</b>	Relay model. This field may correspond exactly to the name of the model (e.g. POKS) or may be an abbreviation of the name (e.g. QPOK = QUADRIPOK).
<b>2 APPLICATION</b>	<p>Sector in which the relay is used. Depending on the sector and application, relays may need to have different finish specifications and to meet special constructional constraints.</p> <p><b>E Series:</b> Energy/Railway fixed equipment These relays are suitable for use in sectors such as electrical power generation, transmission and distribution, petrochemicals, shipbuilding and heavy industries in general, as well as railway fixed equipment.</p> <p><b>R Series:</b> Railway rolling stock Relays suitable for use on rolling stock, particularly for railway applications, trams, trolleybuses and metros. “R” relays comply with the requirements of the standards in this sector.</p>
<b>3 CONFIGURATION A</b>	Available versions and options.
<b>4 CONFIGURATION B</b>	Available versions and options.
<b>5 TYPE OF INPUT SUPPLY</b>	DC voltage, 50 Hz AC voltage, 60 Hz AC voltage, DC + AC voltage.
<b>6 NOMINAL VOLTAGE</b>	Voltage rating of the relay.
<b>7 KEYING POSITION / OPTION</b>	<p>Field used to indicate the possible inclusion of a keying position and/or other options.</p> <ul style="list-style-type: none"> <li>Keying position</li> <li>PCB-mount model (code CS)</li> <li>“R” application (Railway, rolling stock): depending on the model of the relay, coils may be available with operating ranges different to those indicated in EN 60077 standard (0.75 - 1.25 U<sub>n</sub>). Consult the data sheets of the single products for more details.</li> </ul> <p>Example of code for ordering a special operating range = Z01, Z02, Z03, etc:</p> <ul style="list-style-type: none"> <li>Options (low temperature, manual operating lever, etc.)</li> </ul>



## OPTIONS

Depending on the product line, there is a wide range of options available.

Option	Description
<b>P2 / TROPICALIZATION</b>	Tropicalization of coil with epoxy resin for exposure to 95 % RH (@ T 50 °C). This treatment also protects the coil against corrosion that could occur through the combination of humidity and certain chemical agents, such as those found in acid atmospheres (typical of geothermal power stations) or saline atmospheres.
<b>P4GEO / GOLD PLATING</b>	Gold plating of contacts with gold-nickel alloy, thickness $\geq 6 \mu$ , on nickel. This treatment ensures long-term capacity of the contact to conduct lower currents in harsh ambient conditions such as acid atmospheres (typical of geothermal power stations) or saline atmospheres.
<b>P5GEO</b>	<b>P4GEO</b> gold-plating of contacts + <b>P2</b> coil tropicalization.
<b>P6GEO</b>	<b>P4GEO</b> type gold-plating, but applied to contacts, contact terminals and output terminals + <b>P2</b> coil tropicalization.
<b>P7</b>	AgCdO (silver cadmium oxide) contacts.
<b>P8</b>	Gold plating of contacts with gold-cobalt alloy, thickness $\geq 5 \mu$ , knurled fixed contact. This finish allows further improvement of the performance provided by gold-plated contact, compared with P4GEO treatment.
<b>LED</b>	LED indicator showing presence of power supply, wired in parallel with the coil.
<b>FLYBACK DIODE</b>	Polarized component connected in parallel to the coil (type 1N4007 or BYW56 for the rolling stock version) designed to attenuate the overvoltages generated by the coil when the contacts are opened.
<b>VARISTOR</b>	Non-polarized component connected in parallel with the coil, designed to suppress overvoltages higher than the clamping voltage, generated by the coil when de-energized.
<b>TRANSIL</b>	Non-polarized component connected in parallel with the coil. Behavior is similar to that of a varistor, with faster operating times.
<b>LOW TEMPERATURE</b>	Minimum operating temperature -50 °C, only for rolling stock version (option "L").
<b>C.S.</b>	PCB-mount version (for POK-POKS-BIPOK-BIPOKS relays only).
<b>LEVER FOR MANUAL OPERATIONS</b>	Allows manual operation of the relay, with the cover closed, using a screwdriver.

# RELAYS

# RELAYS

# RELAYS

# RELAYS

# RELAYS

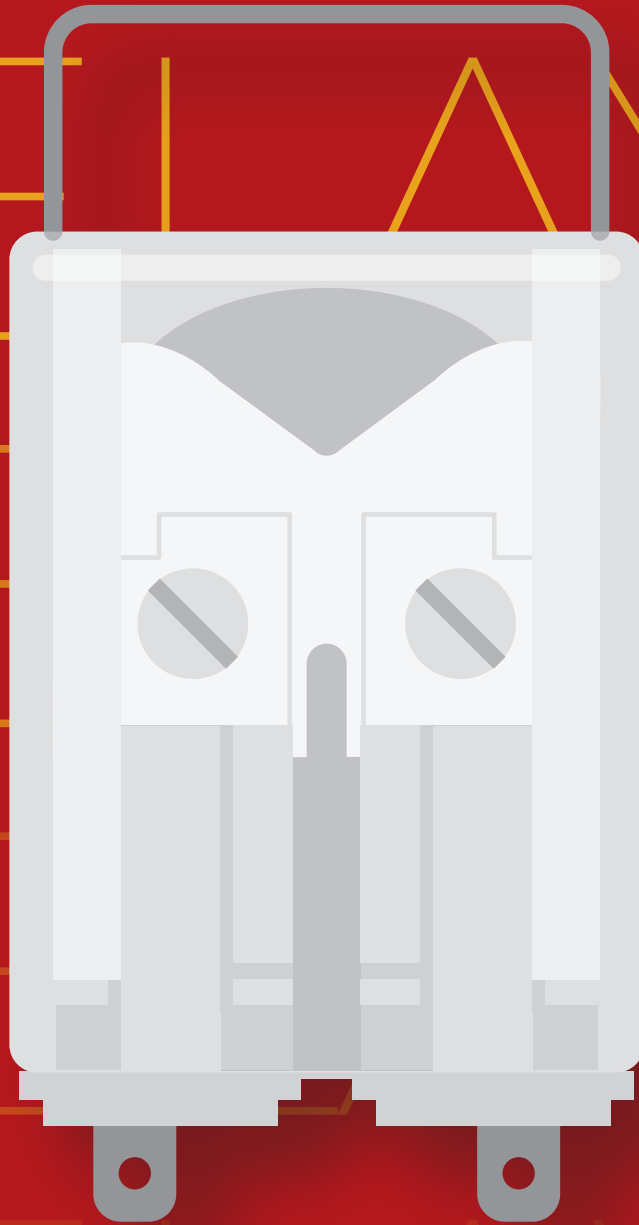

# RELAYS

<b>INSTANTANEOUS MONOSTABLE RELAYS</b> .....	P. 16
POK SERIES .....	P. 18
OK SERIES .....	P. 26
F-OK B SERIES .....	P. 36
<b>INSTANTANEOUS MONOSTABLE RELAYS WITH FORCIBLY GUIDED CONTACTS</b> .....	P. 40
RCG/RDG SERIES .....	P. 42
RGG SERIES .....	P. 48
RMGX SERIES .....	P. 54
<b>TIME DELAY RELAYS (ON PICK-UP OR ON DROP-OUT), LOGIC FUNCTION</b> .....	P. 60
TMM SERIES .....	P. 62
TM SERIES .....	P. 72
TOK SERIES .....	P. 80

# RELAYS

# RELAYS

# RELAYS

# RELAYS

# RELAYS

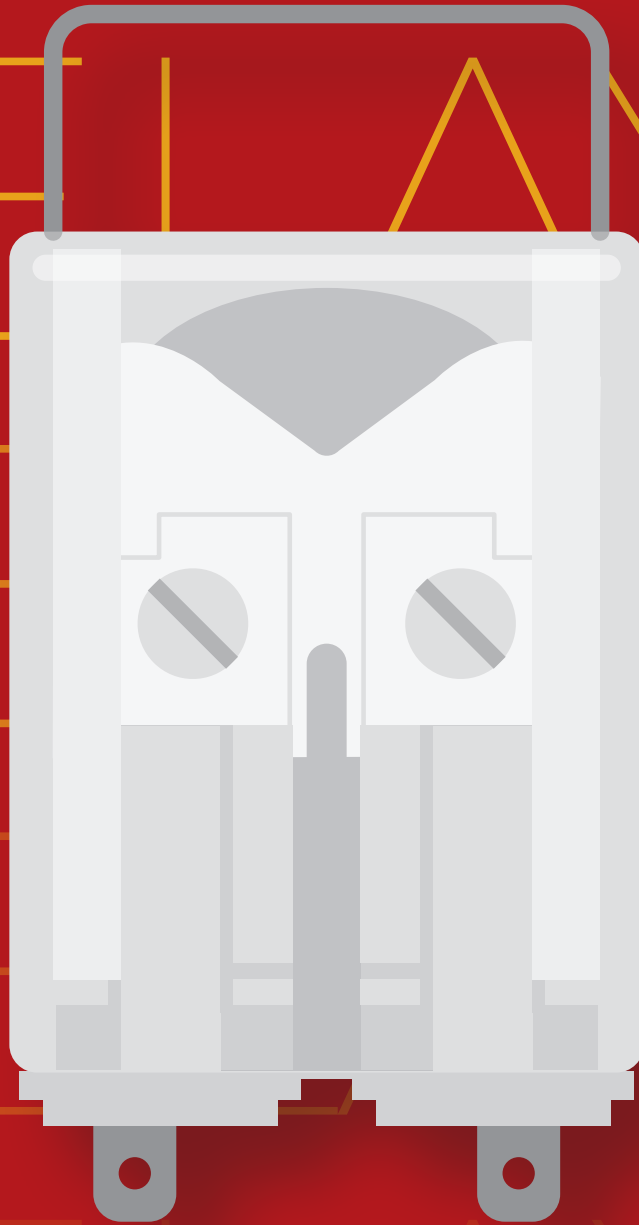

# INSTANTANEOUS MONOSTABLE RELAYS

INSTANTANEOUS  
MONOSTABLE

INSTANTANEOUS  
MONOSTABLE WITH  
FORCIBLY GUIDED CONTACTS

TIME DELAY  
(ON PICK-UP  
OR DROP-OUT)

EXPLANATION OF  
SOCKET NUMBERING

FRONT  
CONNECTION

BACK  
CONNECTION

PCB MOUNT

RETAINING CLIPS

KEYING PINS



RELAYS

## INSTANTANEOUS MONOSTABLE RELAY 2-4-6-8-12 CONTACTS

# POK SERIES

### USER SECTORS



Power generation



Nuclear



Power transmission



Rolling stock



Fixed railway installations



Shipbuilding



Petroleum industry



Heavy industry



POK



BIPOK



TRIPOK

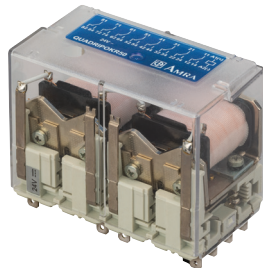

QUADRIPOK

### PRODUCT ADVANTAGES

- Compact plug-in monostable instantaneous relays
- Solid and rugged construction for heavy or intensive duty
- Long life expectancy
- Independent and self-cleaning contacts
- Separate arc breaking chambers
- Magnetic arc blow-out standard
- Excellent shock and vibration resistance
- Option for use in geothermal sites available
- Also available in current-monitoring version
- Also available in PCB-mount version
- Wide variety of configurations and customizations
- Wide range of sockets
- Retaining clip for secure locking of relay on socket
- Transparent cover, pull-out handle
- Positive mechanical keying for relay and socket

### DESCRIPTION

The POK series is made up of five basic models, created from a single module with two contacts that can be used in multiple combinations to provide solutions with **2 - 4 - 6 - 8 and 12 change-over contacts**.

The construction of the relays and careful choice of the materials are such that they ensure long life and considerable ruggedness even in harsh operating environments and in the presence of strong temperature fluctuations.

**A specific treatment (P5GEO or P6GEO)** combining coil tropicalization with gold-plated contacts allows the use of these items in geothermal electric power stations, as relays for signaling functions, for controlling intermediate devices and for all non-power circuits.

Excellent electrical and mechanical performance levels allow the product to be used in the most demanding of sectors such as, for example, control and signaling functions in electricity generating stations, electrical transformer stations, rail transport or in industries with continuous production processes (chemical industry, petroleum industry, rolling mills, cement factories, etc.).





Above all, the excellent ability to withstand shock and vibration allow their use on rolling stock.

Safe and reliable operation is guaranteed by:

- **Contact terminals without connecting braids and soldered joints.** The terminals connecting with the socket are provided by a direct extension of the contacts.
- Mechanism without return springs.
- Adoption of all-metallic operating mechanism, unaffected by the thermal aging that typically degrades organic materials, such as plastics.
- Excellent shock and vibration resistance.
- Notable resistance to high operating temperatures and high thermal shocks.

**The self-cleaning contacts are independent**, being anchored neither one to another nor to a common operating mechanism. Positioned in separate chambers, they enable better breaking of the arc.

In addition, they are equipped with magnetic arc blowout, guaranteeing a particularly efficient break of direct current loads. The common contact is mounted to a separate return device, consisting in a flexible blade designed to ensure uniformity of the pressures on break contacts. Given their dimensions and specifications, POK relays provide the logical complement to power relays of the OK series.

Models	Number of contacts	Nominal current	Rolling stock application
 POK	2	5 A	•
 POKS	2	10 A	•
 BIPOK	4	5 A	•
 BIPOKS	4	10 A	•
TRIPOK	6	5 A	•
TRIPOKS	6	10 A	•
QUADRIPOKS	8	10 A	•
ESAPOKS	12	10 A	•

**FOR CONFIGURATION OF PRODUCT CODE, SEE "ORDERING SCHEME" TABLE**

Coil specifications	POK - POKS	BIPOK - BIPOKS	TRIPOK - TRIPOKS	QUADRIPOKS	ESAPOKS
Nominal voltages $U_n$ <sup>(1)</sup>	DC: 12-24-36-48-72-96-110-125-132-144-220 AC: 12-24-48-110-127-220-230				
Maximum consumption at $U_n$ (DC/AC)	2.5 W / 3.5 VA	3 W / 4 VA	3.5 W / 5.5 VA	6 W / 8 VA	7 W / 11 VA
Operating range	Standard <sup>(1)</sup> DC: 80...115 % $U_n$ AC: 85...110 % $U_n$ Rolling stock version <sup>(2)(3)</sup> DC: 70...125 % $U_n$				
Type of duty	Continuous				
Drop-out voltage <sup>(4)</sup>	DC: > 5 % $U_n$ AC: > 15 % $U_n$				

<sup>(1)</sup> Other values on request. For ESAPOKS, values > 24 V.

<sup>(2)</sup> See "Ordering scheme" table for order code.

<sup>(3)</sup> For operating ranges different to that specified by EN 60077, refer to table "Railways, rolling stock - Special operating ranges".

<sup>(4)</sup> Limit value for supply voltage, expressed as % of the nominal value, beneath which the relay is certainly de-energized.

Contact specifications	POK - POKS	BIPOK - BIPOKS	TRIPOK - TRIPOKS	QUADRIPOKS	ESAPOKS
Number and type	2 CO, form C	4 CO, form C	6 CO, form C	8 CO, form C	12 CO, form C
Current	POK - BIPOK - TRIPOK		POKS - BIPOKS - TRIPOKS - QUADRIPOKS - ESAPOKS		
	Nominal <sup>(1)</sup>		5 A	10 A	
	Maximum peak (1 min) <sup>(2)</sup>		10 A	20 A	
Maximum pulse (10 ms) <sup>(2)</sup>		100 A	150 A		
Example of electrical life expectancy <sup>(3)</sup>	0.2 A – 110 V <sub>DC</sub> – L/R 40 ms: 10 <sup>5</sup> operations 1800 operations / hour		0.5 A – 110 V <sub>DC</sub> – L/R 40 ms: 10 <sup>5</sup> operations 1 A – 110 V <sub>DC</sub> – L/R 0 ms: 10 <sup>5</sup> operations		
Minimum load	Standard contacts		500 mW (20 V, 20 mA)		
	Gold-plated contact <b>P4GEO</b> <sup>(4)</sup>		100 mW (10 V, 5 mA)		
	Gold-plated contact <b>P8</b> <sup>(4)</sup>		50 mW (5 V, 5 mA)		
Maximum breaking voltage	250 V <sub>DC</sub> / 350 V <sub>AC</sub>				
Contact material	AgCu		Ag / AgCu		
Operating time at $U_n$ (ms) <sup>(5)(6)</sup>	DC - AC				
Pick-up (NO contact closing)	≤ 20 - ≤ 20	≤ 25 - ≤ 25	≤ 25 - ≤ 25	≤ 25 - ≤ 25	≤ 25 - ≤ 25
Drop-out (NC contact closing)	≤ 15 - ≤ 20	≤ 20 - ≤ 40	≤ 20 - ≤ 45	≤ 20 - ≤ 40	≤ 20 - ≤ 45

<sup>(1)</sup> On all contacts simultaneously, reduction of 30 %.

<sup>(2)</sup> The maximum peak and pulse currents are those currents that can be handled, for a specified time, by the contact. They do not refer to steady or interrupted currents.

<sup>(3)</sup> For other values, see electrical life expectancy curves.

<sup>(4)</sup> Specifications of contacts on new relay

a. Plating material: **P4GEO**: gold-nickel alloy (> 6 μ) **P8**: gold-cobalt alloy (> 5 μ), knurled contact

b. When the gold-plated contact is subject to heavy loads, it will be degraded on the surface. In this case, the specifications of the standard contact should be taken into consideration. This does not impair relay operation.

<sup>(5)</sup> Unless specified otherwise, the operating time signifies until stabilization of the contact (including bounces).

<sup>(6)</sup> Addition of a flyback diode connected in parallel with the coil (DC version only) causes an increase in operating time when the relay drops out.

 <b>Insulation</b>	
Insulation resistance (at 500 V <sub>DC</sub> ) between electrically independent circuits and between these circuits and ground between open contact parts	> 1,000 MΩ > 1,000 MΩ
Withstand voltage at industrial frequency between electrically independent circuits and between these circuits and ground between open contact parts between adjacent contacts	2 kV (1 min) - 2.2 kV (1 s) 1 kV (1 min) - 1.1 kV (1 s) 2.5 kV (1 min) - 3 kV (1 s)
Impulse withstand voltage (1.2/50 μs - 0.5 J) between electrically independent circuits and between these circuits and ground between open contact parts	5 kV 3 kV

 <b>Mechanical specifications</b>					
Mechanical life expectancy			<b>DC:</b> 20 x 10 <sup>6</sup> <b>AC:</b> 10 x 10 <sup>6</sup> operations		
Maximum switching rate		Mechanical		3,600 operations / hour	
Degree of protection (with relay mounted)			IP40		
Dimensions (mm) <sup>(1)</sup> Weight (g)	POK-POKS	BIPOK-BIPOKS	TRIPOK-TRIPOKS	QUADRIPOKS	ESAPOKS
	20 x 50 x 45 ~ 90	40 x 50 x 45 ~ 170	60 x 50 x 45 ~ 250	80 x 61 x 45 ~ 340	120 x 50 x 45 ~ 520

<sup>(1)</sup> Excluding output terminals

 <b>Environmental specifications</b>	
Operating temperature	Standard OKUIC (-13 to 131) °F (-25 to 55) °C (-13 to 158) °F (-25 to 70) °C
Storage and shipping temperature	(-58 to 185) °F (-50 to 85) °C
Relative humidity	Standard: 75 % RH, Tropicalized: 95 % RH
Resistance to vibrations	5 g - 10 to 55 Hz - 1 min
Resistance to shock	20 g - 11 ms
Fire behavior	V0

 <b>Standards and reference values</b>	
EN 61810-1, EN 61810-2, EN 61810-7	Electromechanical elementary relays
EN 60695-2-10	Fire behavior
EN 61000	Electromagnetic compatibility
EN 60529	Degree of protection provided by enclosures

Unless otherwise specified, the products are designed and manufactured according to the requirements of the above-mentioned European and International standards. In accordance with EN 61810-1, all items of technical data are referred to ambient temperature 23 °C, atmospheric pressure 96 kPa and 50 % humidity. Tolerance for coil resistance, nominal electrical input and nominal power is ± 7 %.

 <b>Railways, rolling stock - Standards</b>	
EN 60077	Electric equipment for rolling stock — general service conditions and general rules
EN 50155	Electronic equipment used on rolling stock
EN 61373	Shock and vibration tests, CAT 1, Class B
EN 45545-2	Fire behavior, CAT E10, Requirement R26, V0
ASTM E162, E662	Fire behavior

## Railways, rolling stock - Special operating ranges for POK(s) - BIPOK(s) relays <sup>(1)</sup>

Nominal voltage	Minimum pick-up voltage	Maximum operating voltage	Order symbol <sup>(1)</sup>
24 V <sub>DC</sub>	18	33	Z01
24 V <sub>DC</sub>	16	32	Z02
24 V <sub>DC</sub>	16.8	32	Z03
24 V <sub>DC</sub>	19	30	Z04
36 V <sub>DC</sub>	28	46	Z01
72 V <sub>DC</sub>	55	104	Z01
72 V <sub>DC</sub>	55	96	Z02
110 V <sub>DC</sub>	77	144	Z01

<sup>(1)</sup> To order the relay with the special operating range, indicate the “Z0x” symbol in the “Keying position” field of the ordering scheme. The special range may be subject to operating specifications different from standard specifications. Please contact us for further information.

## Configuration options

P2	Tropicalization of the coil with epoxy resin for use with 95 % RH (@ T 50 °C). This treatment also protects the coil against corrosion which could occur by combination of the humidity with certain chemical agents, such as those found in acid atmospheres (typical of geothermal power stations) or saline atmospheres.
P4GEO	Gold plating of contacts with gold-nickel alloy, thickness $\geq 6 \mu$ . This treatment ensures long-term capacity of the contact to conduct lower currents in harsh ambient conditions such as acid atmospheres (typical of geothermal power stations) or saline atmospheres.
P5GEO	<b>P4GEO</b> gold-plating of contacts + <b>P2</b> coil tropicalization.
P6GEO	<b>P4GEO</b> type gold-plating, but applied to contacts, contact terminals and output terminals + <b>P2</b> coil tropicalization.
P7	AgCdO (silver cadmium oxide) contacts.
P8	Gold plating of contacts with gold-cobalt alloy, thickness $\geq 5 \mu$ , knurled fixed contact. This finish allows further improvement of the performance provided by gold-plated contact, compared to P4GEO treatment.
LED	LED indicator showing presence of power supply, wired in parallel with the coil.
FLYBACK DIODE	Polarized component connected in parallel with the coil (type 1N4007 or BYW56 for rolling stock version) designed to suppress overvoltages generated by the coil when de-energized.
VARISTOR	Non-polarized component connected in parallel with the coil, designed to suppress overvoltages higher than the clamping voltage, generated by the coil when de-energized.
TRANSIL	Non-polarized component connected in parallel with the coil. Behavior is similar to that of a varistor, with faster operating times.
LOW TEMPERATURE	Minimum operating temperature -50 °C, only for rolling stock version (option “L”).
C.S.	PCB-mount version (for POK-POKS-BIPOK-BIPOKS only).

## Ordering scheme

Model	Number of CO contacts	Product code	Application <sup>(1)</sup>	Configuration A	Configuration B	Label	Type of power supply	Nominal voltage (V) <sup>(2)</sup>	Keying position <sup>(3)</sup> / option
POK	2 - 5 A	POK	<b>E:</b> Energy Railway Fixed Equipment	1: Standard	<b>0:</b> Standard	F	C: V <sub>DC</sub> A: V <sub>AC</sub> 50 Hz H: V <sub>AC</sub> 60 Hz	012 - 024 - 036 048 - 072 - 096 100 - 110 - 125 127 - 132 - 144 220 - 230	XXX <b>CS</b> = PCB-mount version <b>L</b> = low temperature**
POKS	2 - 10 A	POKS		2: Diode //					
BIPOK	4 - 5 A	BPOK		3: Varistor					
BIPOKS	4 - 10 A	BPOKS		4: LED					
TRIPOK	6 - 5 A	TPOK	<b>R:</b> Railway Rolling Stock*	5: Diode // + LED	<b>6:</b> P6 GEO				
TRIPOKS	6 - 10 A	TPOKS		6: Varistor + LED					
QUADRIPOKS	8 - 10 A	QPOK		7: Transil					
ESAPOKS	12 - 10 A	EPOK		8: Transil + LED					

Example	TPOKS	E	3	0	F	A	230	
	TPOKSE30F-A230 - TRIPOKS relay, ENERGY series, nominal voltage 230 V <sub>AC</sub> , equipped with varistor							
Example	BPOKS	R	5	8	F	C	024	
	BPOKSR58F-C024 - BIPOKS relay, ROLLING STOCK series, nominal voltage 24 V <sub>DC</sub> , equipped with diode, LED, with P8 finish (gold-plated contacts)							
Example	POK	R	1	0	F	C	110	L
	POKR10F - C110 L - POK relay, rolling stock series, nominal voltage 110 V <sub>DC</sub> with option "L" (low temp.)							

<sup>(1)</sup> **E = ENERGY:** All applications, except for railways rolling stock. Suitable on energy production, transport and distribution plants, railways fixed equipment, petrochemical and heavy industry.

**R = RAILWAYS, ROLLING STOCK:** Application on board rolling stock (rail-tram-trolley vehicles). Electrical specifications according to EN 60077.

Other product series available:

**RAILWAYS, FIXED EQUIPMENT:** Approved and conforming relays and products to RFI (FS Group) specification no. RFI DPRIM STF IFS TE 143 A. For the list of RFI approved and conforming products, consult dedicated catalog "RAILWAY SERIES – RFI APPROVED".

**STATIONS:** ENEL approved material meeting LV15/LV16 specifications. For the list of ENEL approved and conforming products, consult the dedicated catalog "STATIONS SERIES – LV15-LV16-LV20".

<sup>(2)</sup> Other values on request.

<sup>(3)</sup> Optional value. PCB-mount version available for POK - POKS - BIPOK - BIPOKS only. Multiple selection possible (e.g. CS - L). The positive mechanical keying is applied according to the manufacturer's model (not available for PCB-mount versions).

\* Except ESAPOKS

\*\* Except TRIPOKS, QUADRIPOKS and ESAPOKS

## Wiring diagram

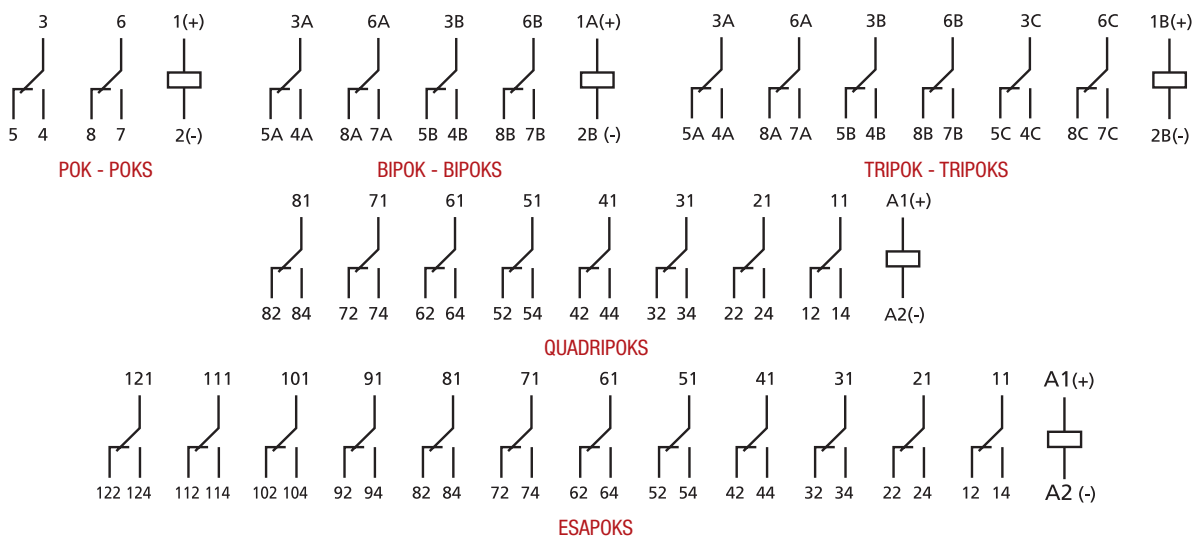

## Dimensions

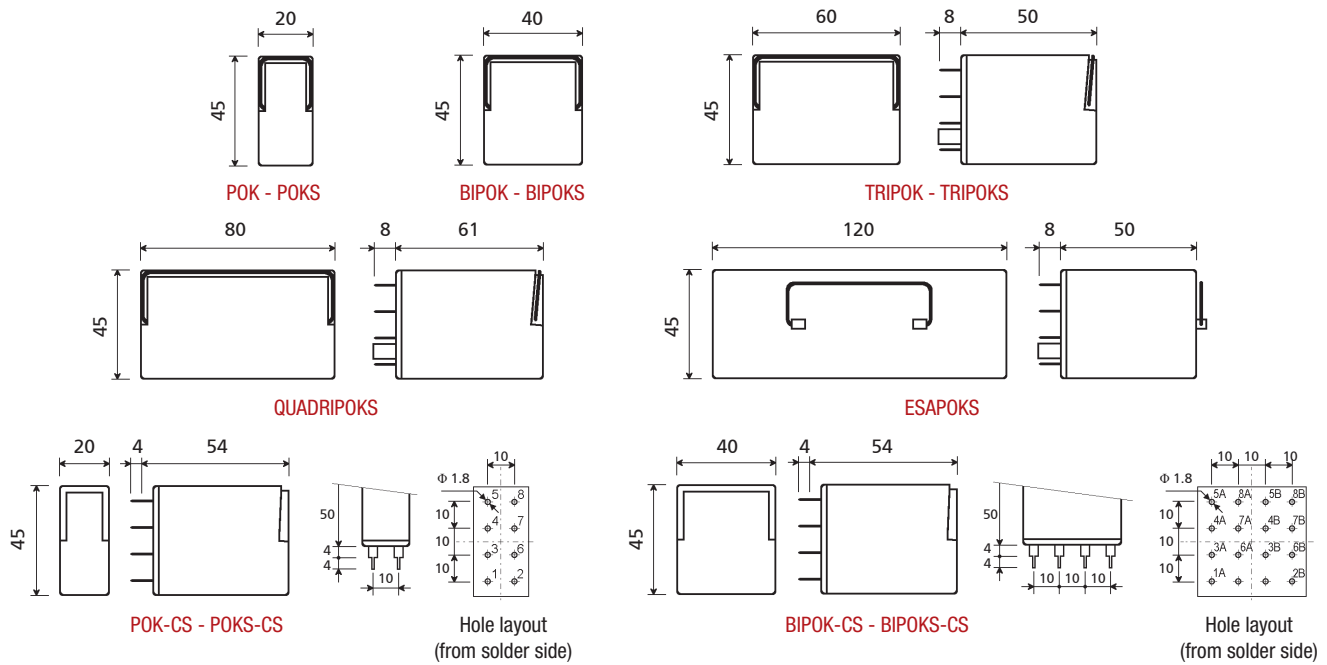

## Electrical life expectancy <sup>(1)</sup>

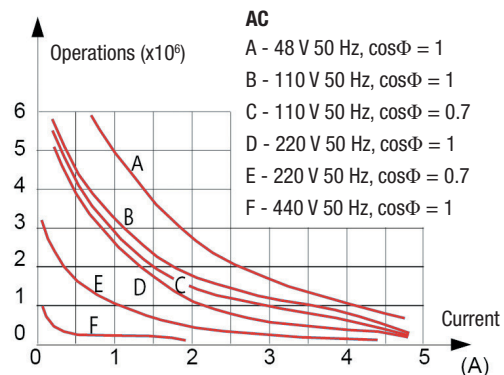
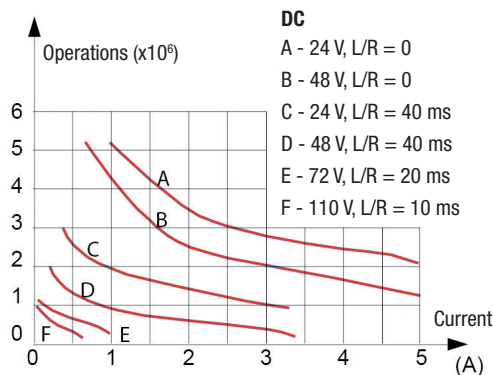

### Examples of electrical life expectancy:

48 V<sub>DC</sub> - 5 A - L/R = 10 ms : 5 × 10<sup>5</sup> operations  
 80 V<sub>DC</sub> - 5 A - Resistive: 5 × 10<sup>5</sup> operations  
 110 V<sub>DC</sub> - 0.5 A - L/R = 10 ms: 5 × 10<sup>5</sup> operations

220 V<sub>DC</sub> - 0.2 A - L/R = 10 ms: 10<sup>5</sup> operations  
 110 V<sub>AC</sub> - 5 A - cos $\Phi$  = 0.7: 5 × 10<sup>5</sup> operations  
 220 V<sub>AC</sub> - 3 A - cos $\Phi$  = 0.7: 5 × 10<sup>5</sup> operations  
 440 V<sub>AC</sub> - 0.2 A - Resistive: 5 × 10<sup>5</sup> operations

Switching frequency 1,200 operations / hour, 50 % cycle.

Sockets	POK - POKS	BIPOK - BIPOKS	TRIPOK - TRIPOKS	QUADRIPOKS	ESAPOKS
Number of terminals	8	16	24	32	48
For wall or rail mounting					
Spring clamp, wall or DIN H35 rail mounting	PAIR080	PAIR160	PAIR240	PAIR320	PAIR480
Screw, wall or DIN H35 rail mounting	50IP20-I DIN	48BIP20-I DIN	78BIP20-I DIN	96IP20-I DIN	156IP20-I DIN
Screw, wall mounting	50L	48BL	78BL	96BL	156BL
Double faston, wall mounting	51L	48L	78L	-	-
For flush mounting					
Double faston (4.8 x 0.8 mm)	ADF1	ADF2	ADF3	ADF4	ADF6
Screw	53IL	43IL	73IL	-	-
For mounting on PCB					
	65 <sup>(1)</sup>	65	-	-	-

<sup>(1)</sup> Suitable for mounting 2 relays side by side.

Retaining clips – Correspondence with sockets	POK - POKS	BIPOK - BIPOKS	TRIPOK - TRIPOKS	QUADRIPOKS	ESAPOKS
Number of clips per relay	1	1 <sup>(1)</sup>	2	2	2
SOCKET MODEL	CLIP MODEL				
For wall or rail mounting					
PAIR080, PAIR160, PAIR240, PAIR320, PAIR480	RPB48	RPB48	RPB48	RQ48	RPB48
50IP20-I DIN, 48BIP20-I DIN, 78BIP20-I DIN, 96IP20-I DIN, 156IP20-I DIN	RPB48	RPB48	RPB48	RQ48	RPB48
50L, 48BL, 78BL, 96BL, 156BL	RPB48	RPB48	RPB48	RQ48	RPB48
51L, 48L, 78L	RPB48	RPB48	RPB48	-	-
For flush mounting					
ADF1, ADF2, ADF3, ADF4, ADF6	RPB48	RPB48	RPB48	RQ48	RPB48
ADF, 53IL, 43IL, 73IL <sup>(2)</sup>	RPB43	RPB43	RPB43	-	-
For mounting on PCB					
	65	RPB43	RPB43	-	-

<sup>(1)</sup> Assume two clips for use on rolling stock.

<sup>(2)</sup> Insert the clip before fastening the socket on the panel.

### Mounting tips

- The preferred mounting position is on the wall, with the relay positioned horizontally in the reading direction on the nameplate.
- For correct use of the relays, they should be spaced apart by at least 5 mm in the horizontal direction and 20 mm in the vertical direction. This is to allow correct upward dissipation of the heat generated by the coil. Set these distances according to the socket used. Distances can be reduced depending on the environmental application conditions and on the relay duty cycle.
- For safe and secure operation, it is advisable to use retaining clips.
- No special maintenance is required.
- Condensation can form inside the relay when powered up and the outside ambient temperature is cold; this is quite normal and does not affect the operation of the relay. The plastic materials of the relay do not possess hygroscopic properties.





RELAYS

## INSTANTANEOUS MONOSTABLE RELAY 2-4-6-8-12 CONTACTS

## OK SERIES

## USER SECTORS



Power generation



Nuclear



Power transmission



Rolling stock



Fixed railway installations



Shipbuilding



Petroleum industry



Heavy industry



OKUIC

## PRODUCT ADVANTAGES

- Plug-in monostable instantaneous relay
- Solid and rugged construction for heavy or intensive duty
- Very long electrical life expectancy and exceptional endurance
- Patent operating mechanism, designed to ensure high contact pressure
- Ample clearance between open contact elements (from 1.2 to 4 mm)
- Independent and self-cleaning contacts with high breaking capacity
- Magnetic arc blow-out for higher breaking capacity
- Excellent shock and vibration resistance
- Wide variety of configurations and customizations
- Option for use in geothermal sites available
- Wide range of sockets
- Retaining clip for secure locking of relay on socket
- Transparent cover, pull-out handle
- Positive mechanical keying for relay and socket

## DESCRIPTION

The OK series is made up of seven basic models, created from **a patented common operating mechanism equipped** with four contacts. Solutions with eight or twelve contacts are obtainable by using two or three relays in combination.

The construction of the relays and careful choice of the materials are such that they ensure long life and considerable ruggedness even in harsh operating environments and when subject to strong thermal shocks. A **specific treatment (P5GEO or P6GEO)** combining coil tropicalization with gold-plated contacts allows the use of these items in geothermal electric power stations, as final relays for controlling field devices and for all power circuits.

The relays in the OK Series use a patented switching mechanism designed to minimize friction, resulting in a mechanical life expectancy of at least 100,000,000 operations.

This is made possible thanks to:

- The use of a solenoid with a core drawn in toward the main air gap, located at the center of the coil, the only position in which the available magnetic flux can be exploited to the full.
- The core motion being limited to the minimum, thereby optimizing mechanical forces and reducing friction. The motion is amplified by means of a W linkage, which allows an appreciable displacement of the contact (> 4 mm in the case of the version with NO contacts).

- The coil of elongated cylindrical geometry, best able to ensure high efficiency and effective dissipation of the heat produced.

Each contact is mounted on individual and independent blades, which are able to provide optimum shock and vibration resistance.

In particular, this generates pressure of around 0.8...1 N on the make and break contacts, which is unparalleled by other products.

The common contact slides against the fixed poles (NO and NC contacts) both when opening and when closing, which ensures a notably effective self-cleaning action.

With ample clearance between the open contact elements, it becomes possible to **guarantee an impulse withstand voltage of 5 kW** between the poles of the single contact.

Excellent electrical and mechanical performance levels allow the product to be used in the most demanding of sectors such as, for example, control and signaling functions in electricity generating stations, electrical transformer stations, rail transport or in industries with continuous production processes (chemical industry, petroleum industry, rolling mills, cement factories, etc.).

Above all, the excellent ability to withstand shock and vibration allow their use in seismic environments or on rolling stock.

## Description of models

There are seven relay models in the OK Series (OK, OKS, OKFC, OKSFC, OKSCD, OKSGcCd and OKUIC). The outputs are available on 16 terminals of standard dimensions (5 x 0.8) mm, evenly and symmetrically divided into four rows spaced 10 mm apart, in both directions. Internal connections are ordered symmetrically. Turning the relay through 180° on its connector has the effect simply of changing the contacts, without affecting operation (except in the case of relays with a polarized power input).

### OK – OKS

The OK relay offers ruggedness, easy installation, high breaking capacity (with magnetic arc blow-out, model OKS), safe operation and adaptability to any kind of circuit, making it suitable for all heavy duty applications in the field of remote control systems and automation. The distance between contacts is 2.2 mm. Superior shock and vibration resistance ensures that contacts are able to hold their operating position even when exposed to a shock force of 30 g - 1 ms. No opening of break contacts up to 3 g.

On the OKS model, a powerful magnetic arc blow-out located between the four change-over contacts has the effect of generating a permanent magnetic field. When an inductive load circuit is broken, the resulting arc is swiftly extended and finally extinguished through the action of the magnetic field created by the blow-out.

### OKFC – OKSFC – OKUIC

The OKFC relay is an energy saving component. The distance between contacts is 1.2 mm. Contact pressures and shock and vibration resistance are the same as specified for OK/OKS models. In the case of DC loads, the breaking capacity is reduced from that of the OK relay, although the addition of the magnetic arc blow-out (model OKSFC) provides breaking capacity of up to 15 A at 120 V<sub>DC</sub> (see example of electrical life expectancy). On the OKSFC model, a powerful magnetic arc blow-out located between the four change-over contacts has the effect of generating a permanent magnetic field. When an inductive load circuit is broken, the resulting arc is swiftly extended and extinguished through the action of the magnetic field created by the blow-out. With direct current, breaking capacity is doubled. For DC and AC currents that can be broken without the blow-out, the effect of having this feature available will be to reduce wear on the contacts, doubling electrical life expectancy.

The connection of two contacts in series increases electrical life expectancy and doubles breaking capacity when handling direct current.

The connection of two contacts in parallel likewise increases electrical life expectancy.

In the event that the four contacts are all available for breaking purposes, it is possible to use a series/parallel connection arrangement as illustrated below. In the case of high voltages, from 250 V upwards, it is best to avoid breaking opposite polarities on adjacent contacts.

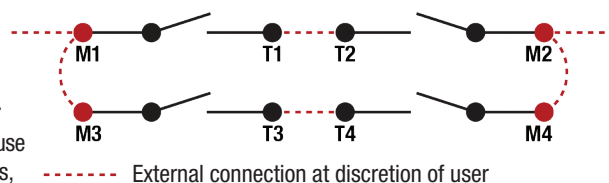

The use of the OKFC or OKSFC relay is advisable whenever the requirement is for detecting loss of voltage, hence where relays are permanently powered up, or when the ambient temperature may reach 70 °C. These relays can be powered up permanently, even at the maximum voltage of the specified operating range; they can also handle wide fluctuations in voltage and consequently are able to respond, for example, to standards for rolling stock, as in the case of the OKUIC model, which has a coil with a wide operating range.

### OKSCD

The silver-coated contacts of normal relays can fuse together when closed if exposed to a peak current of 50 A for at least 5 ms. Using cadmium oxide contacts, the surfaces will fuse only at currents higher than 150 A. With magnetic arc blow-out fitted as standard to these relays, there is no possibility of the arc creating a hot spot between the contacts that could cause them to become welded together.

This relay is especially suitable for handling highly inductive direct current loads, and circuits with filament lamps where the closing of contacts can produce current peaks of up to 10 or 15 times the nominal strength (public or industrial lighting systems). It can also be used for starting small electric motors and other appliances that produce high transient currents. The OKSCD relay has an electrical life expectancy equal to that of the OKS relay, but is also suitable for use with circuits generating high transient currents, given the factors indicated above. Controlling a circuit with 600 W filament lamps connected to a 110 V<sub>AC</sub> supply, for example, the OKSCD relay is capable of 1,500,000 operations.

### OKSGcCd

The OKSGcCd relay has a longer electrical life expectancy than the OKSCd model. It has four normally open contacts, and a distance between contacts of > 4 mm. Magnetic arc blow-out is fitted as a standard feature. The OKSGcCd relay can be used with heavily inductive DC loads, where there is no need for change-over contacts.

### OKB184

The OKB184 models are equipped as standard with a blow-out magnet and have low coil consumption. As these relays are K3-qualified, they are the relays of reference in the nuclear sector.

Models	Number of contacts	Continuous Duty	Magnetic arc blow-out	AgCdO contacts	Long travel	Rolling stock application
OK	4 <sup>(1)</sup>					
OKS			•			
OKFC		•				
OKSFC		•	•			
OKSCd			•	•		
OKSGcCd			•	•	•	
OKUIC		•	•			•
 OKB184				•		

<sup>(1)</sup> Versions with 8 and 12 contacts available (excluding OKUIC, OKSCd and OKSGcCd).

**FOR CONFIGURATION OF PRODUCT CODE, SEE "ORDERING SCHEME" TABLE**

Coil specifications	OK - OKS	OKFC - OKSFC	OKSCd - OKSGcCd	OKUIC	OKB184
Nominal voltages $U_n$ <sup>(1)</sup>	DC: 12-24-36-48-72-110-125-132-144-220 AC: 12-24-48-110-127-220-230-380			48, 125 V <sub>DC</sub>	
Maximum consumption at $U_n$ (DC/AC) <sup>(2)</sup>	4.5 W / VA	3.5 W / VA	5 W / VA	3.5 W	3.5 W
Operating range <sup>(3)</sup>	DC: 80...110 % $U_n$ AC: 85...115 % $U_n$	DC: 80...120 % $U_n$ AC: 85...115 % $U_n$	DC: 80...110 % $U_n$ AC: 80...110 % $U_n$	DC: 70...125 % $U_n$ <sup>(3)</sup>	DC: 80...110 % $U_n$
Type of duty	Continuous at $U_n$ <sup>(4)</sup>	Continuous	Continuous at $U_n$ <sup>(4)</sup>	Continuous	Continuous
Drop-out voltage <sup>(5)</sup>	DC: > 5 % $U_n$ AC: > 15 % $U_n$				

<sup>(1)</sup> Other values on request.

<sup>(2)</sup> For versions with 8 and 12 contacts, double and triple the value respectively.

<sup>(3)</sup> For operating ranges different to that specified by EN 60077, refer to table "Special operating ranges for OKUIC relay" on page 30.

<sup>(4)</sup> Continuous duty is possible at the maximum voltage of the operating range at T<sub>max</sub>: 40 °C.

<sup>(5)</sup> Limit value for supply voltage, expressed as % of the nominal value, beneath which the relay is certain to be de-energized.

Contact specifications	OK - OKS - OKFC - OKSFC - OKUIC - OKB184	OKSCd	OKSGcCd		
Number and type <sup>(1)</sup>	4 CO, form C	4 CO, form C	4 NO		
Current					
Nominal <sup>(2)</sup>	10 A	10 A			
Maximum peak (1 min) <sup>(3)</sup>	20 A	20 A			
Maximum pulse (10 ms) <sup>(3)</sup>	150 A	250 A			
Example of electrical life expectancy <sup>(4)</sup>					
1800 operations / hour	OK	0.7 A – 120 V <sub>DC</sub> – L/R 0 ms: 5.5 x 10 <sup>5</sup> operations			
	OKS	1 A – 120 V <sub>DC</sub> – L/R 40 ms: 5 x 10 <sup>5</sup> operations			
	OKFC	0.5 A – 110 V <sub>DC</sub> – L/R 40 ms: 10 <sup>5</sup> operations			
	OKSFC - OKUIC	0.7 A – 132 V <sub>DC</sub> – L/R 40 ms: 10 <sup>5</sup> operations			
	OKSCd	1 A – 120 V <sub>DC</sub> – L/R 40 ms: 5 x 10 <sup>5</sup> operations			
	OKSGcCd	5 A – 110 V <sub>DC</sub> – L/R 20 ms: 2 x 10 <sup>5</sup> operations			
Minimum load	Standard contacts	500 mW (20 V, 20 mA)			
	Gold-plated contacts <sup>(5)</sup>	200 mW (20 V, 5 mA)			
Maximum breaking voltage	350 V <sub>DC</sub> / 440 V <sub>AC</sub>				
Contact material	AgCu		AgCdO		
Operating time at $U_n$ (ms) <sup>(6) (7)</sup>	OK-OKS-OKSCd	OKFC-OKSFC	OKB184	OKSGcCd	OKUIC
	DC – AC				
Pick-up (NO contact closing)	≤ 28 - ≤ 40	≤ 38 - ≤ 40	≤ 30	≤ 30 - ≤ 45	≤ 40
Drop-out (NC contact closing)	≤ 20 - ≤ 70	≤ 18 - ≤ 80	≤ 20	-	≤ 18

See next page for <sup>(1)</sup> <sup>(2)</sup> <sup>(3)</sup> <sup>(4)</sup> <sup>(5)</sup> <sup>(6)</sup> <sup>(7)</sup>.

<sup>(1)</sup> Versions with 8 and 12 CO contacts available, excluding OKUIC, OKSCd and OKSGcCd.

<sup>(2)</sup> On all contacts simultaneously.

<sup>(3)</sup> The maximum peak and pulse currents are those currents that can be handled, for a specified time, by the contact. They do not refer to steady or interrupted currents.

<sup>(4)</sup> For other values, see electrical life expectancy curves.

<sup>(5)</sup> Specifications of contacts on new relay

a. Plating material: **P4GEO**: gold-nickel alloy (> 6 µ).

b. When the gold-plated contact is subject to heavy loads, it will be degraded on the surface. In this case, the specifications of the standard contact should be taken into consideration. This does not impair relay operation.

<sup>(6)</sup> Unless specified otherwise, the operating time signifies until stabilization of the contact (including bounces).

<sup>(7)</sup> Addition of a flyback diode connected in parallel with the coil (DC version only) causes an increase in operating time when the relay drops out.

Insulation		
Insulation resistance (at 500 V <sub>DC</sub> )	between electrically independent circuits and between these circuits and ground	> 1,000 MΩ
	between open contact parts	> 1,000 MΩ
Withstand voltage at industrial frequency	between electrically independent circuits and between these circuits and ground	2 kV (1 min) - 2.2 kV (1 s)
	between open contact parts	1 kV (1 min) - 1.1 kV (1 s)
	between adjacent contacts	2.5 kV (1 min) - 3 kV (1 s)
Impulse withstand voltage (1.2/50 µs - 0.5 J)	between electrically independent circuits and between these circuits and ground	5 kV
	between open contact parts	3 kV

Mechanical specifications						
Mechanical life expectancy			100 x 10 <sup>6</sup> operations			
Maximum switching rate		Mechanical		3,600 operations / hour		
Degree of protection (with relay mounted)			IP20 / IP40 or IP50 as an option <sup>(3)</sup>			
Type of power supply, n°C0	V <sub>DC</sub> , 4 CO	V <sub>AC</sub> , 4 CO	V <sub>DC</sub> , 8 CO	V <sub>AC</sub> , 8 CO	V <sub>DC</sub> , 12 CO	V <sub>AC</sub> , 12 CO
Dimensions (mm) <sup>(1) (2)</sup>	45 x 97 x 45	45 x 109 x 45	91.5 x 97 x 45	91.5 x 109 x 45	138 x 97 x 45	138 x 109 x 45
Weight (g)	~ 280	~ 280	~ 590	~ 590	~ 890	~ 890

<sup>(1)</sup> Excluding output terminals.

<sup>(2)</sup> OKUIC relay: height of 109 mm for standard version, height of 97 mm for version with LED, DIODE, VARISTOR.

<sup>(3)</sup> To order the relay with IP40 or IP50 protection, configure the ordering code by the "Keying position" column in "Ordering scheme".

Environmental specifications		
Operating temperature	Standard	(-13 to 131) °F (-25 to 55) °C
	OKUIC	(-13 to 158) °F (-25 to 70) °C
Storage and shipping temperature		(-40 to 185) °F (-40 to 85) °C
Relative humidity		Standard: 75 % RH, Tropicalized: 95 % RH
Resistance to vibrations		5 g - 10 to 60 Hz - 1 min
Resistance to shock		30 g - 11 ms
Fire behavior		V0

Standards and reference values	
EN 61810-1, EN 61810-2, EN 61810-7	Electromechanical elementary relays
EN 60695-2-10	Fire behavior
EN 50082-2	Electromagnetic compatibility
EN 60529	Degree of protection provided by enclosures

Unless otherwise specified, the products are designed and manufactured according to the requirements of the above-mentioned European and International standards. In accordance with EN 61810-1, all items of technical data are referred to ambient temperature 23 °C, atmospheric pressure 96 kPa and 50 % humidity. Tolerance for coil resistance, nominal electrical input and nominal power is ± 7 %.



### Railways, rolling stock - Standards

EN 60077	Electric equipment for rolling stock — general service conditions and general rules
EN 50155	Electronic equipment used on rolling stock
EN 61373	Shock and vibration tests, CAT 1, Class B
EN 45545-2	Fire behavior, CAT E10, Requirement R26, V0
ASTM E162, E662	Fire behavior



### Railways, rolling stock - Special operating ranges for OKUIC relay

Nominal voltage	Minimum pick-up voltage	Maximum operating voltage
24 V <sub>dc</sub>	18	33
36 V <sub>dc</sub>	28	46
72 V <sub>dc</sub>	55	104
110 V <sub>dc</sub>	77	144
128 V <sub>dc</sub>	85	160



### Configuration options

P2	Tropicalization of the coil with epoxy resin for use with 95 % RH (@ T 50 °C). This treatment also protects the coil against corrosion which could occur by combination of the humidity with certain chemical agents, such as those found in acid atmospheres (typical of geothermal power stations) or saline atmospheres.
P4GEO	Gold plating of contacts with gold-nickel alloy, thickness $\geq 6 \mu$ . This treatment ensures long-term capacity of the contact to conduct lower currents in harsh ambient conditions such as acid atmospheres (typical of geothermal power stations) or saline atmospheres.
P5GEO	<b>P4GEO</b> gold-plating of contacts + <b>P2</b> coil tropicalization.
P6GEO	<b>P4GEO</b> type gold-plating, but applied to contacts, contact terminals and output terminals + <b>P2</b> coil tropicalization.
LED	LED indicator showing presence of power supply, wired in parallel with the coil.
FLYBACK DIODE	Polarized component connected in parallel with the coil (type 1N4007 or BYW56 for rolling stock version) designed to suppress overvoltages generated by the coil when de-energized.
VARISTOR	Non-polarized component connected in parallel with the coil, designed to suppress overvoltages higher than the clamping voltage, generated by the coil when de-energized.
TRANSIL	Non-polarized component connected in parallel with the coil. Behavior is similar to that of a varistor, with faster operating times.
IP40	IP40 protection with “6” handle or closure with screws.
IP50	IP50 protection with “6” handle (only for 4 CO version).
8 CONTACTS	Version with 8 change-over contacts, obtained using 2 x 4 CO relay, coils connected in series.
12 CONTACTS	Version with 12 change-over contacts, obtained using 3 x 4 CO relay, coils connected in series.

**Ordering scheme**

Product code	Number of contacts	Application <sup>(1)</sup>	Configuration A	Configuration B	Label	Type of power supply	Nominal voltage (V) <sup>(2)</sup>	Keying position <sup>(3)</sup>
OK OKS OKFC OKSFC OKUIC OKScd OKSGcCd	<b>4:</b> CO <sup>(4)</sup> <b>8:</b> 8 CO <b>12:</b> 12 CO	<b>E:</b> Energy Railway Fixed Equipment  <b>R:</b> Railway Rolling Stock	1: Standard 2: Diode // 3: Varistor 4: LED 5: Diode // + LED 6: Varistor + LED 7: Transil 8: Transil + LED	0: Standard 2: P2 4: P4 GEO 5: P5 GEO 6: P6 GEO 7: P7 8: P8	F	C: V <sub>DC</sub> A: V <sub>AC</sub> 50 Hz H: V <sub>AC</sub> 60 Hz	012 - 024 - 036 048 - 072 - 100 110 - 115 - 125 127 - 132 - 144 220 - 230 - 380	XXX <b>A:</b> IP50 <b>B:</b> IP40

Example

<b>OKSFC</b>	<b>E</b>	<b>2</b>	<b>0</b>	<b>F</b>	<b>C</b>	<b>110</b>	
--------------	----------	----------	----------	----------	----------	------------	--

OKSFCE20F-C110 - OKSFC relay, ENERGY series, nominal voltage 110 V<sub>DC</sub>, equipped with a flyback diode

<sup>(1)</sup> **E = ENERGY:** All applications, except for railways rolling stock. Suitable on energy production, transport and distribution plants, railways fixed equipment, petrochemical and heavy industry.  
**R = RAILWAYS, ROLLING STOCK:** Application on board rolling stock (rail-tram-trolley vehicles). Electrical specifications according to EN 60077.  
 Other product series available:  
**RAILWAYS, FIXED EQUIPMENT:** Approved and conforming relays and products to RFI (FS Group) specification no. RFI DPRIM STF IFS TE 143 A. For the list of RFI approved and conforming products, consult dedicated catalog "RAILWAY SERIES – RFI APPROVED".  
**STATIONS:** ENEL approved material meeting LV15/LV16 specifications. For the list of ENEL approved and conforming products, consult the dedicated catalog "STATIONS SERIES – LV15-LV16-LV20".

<sup>(2)</sup> Other values on request. Voltage 380 V available as V<sub>AC</sub> only.  
<sup>(3)</sup> Optional value. The positive mechanical keying is applied according to the manufacturer's model.  
<sup>(4)</sup> For the standard version with four contacts, the field must be left empty.

Coded Products		
	<b>OKB 184</b>	<b>OK SFC UIC</b>
48 V <sub>DC</sub>	Please contact us	-
72 V <sub>DC</sub>	-	P01 4561 93
125 V <sub>DC</sub>	Please contact us	-

**Wiring diagram**

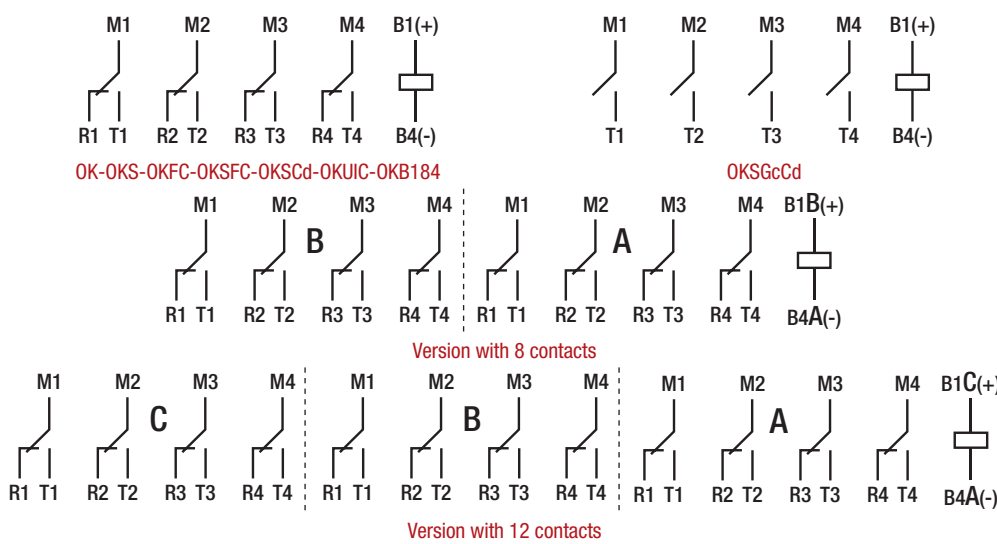

## Dimensions

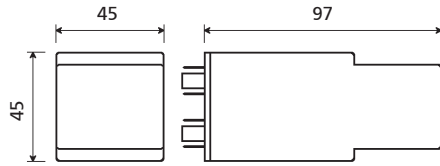

All OK DC relays and OKUIC  
with Diode and/or LED option

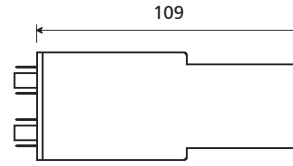

All AC OK and OKUIC relays

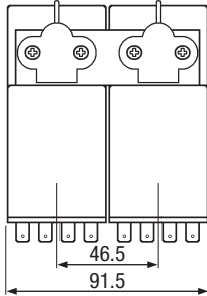

Version with 8 contacts

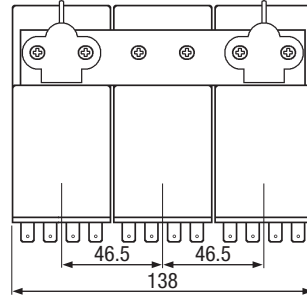

Version with 12 contacts

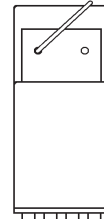

6B handle IP20  
(standard)

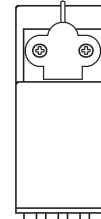

6B handle IP40 <sup>(1)</sup>  
(OKUIC)

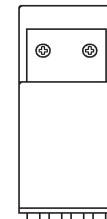

Closure with  
screws IP40 <sup>(1)</sup>

6 handle IP50 <sup>(1)</sup>

<sup>(1)</sup> IP40 or IP50 protection can requested as an option. See "Ordering scheme" for code details.

## Examples of electrical life expectancy

	U (Contact)	I (A)	L/R (ms) cosΦ	Operations	Notes		U (Contact)	I (A)	L/R (ms) cosΦ	Operations	Notes
OK	540 V <sub>AC</sub>	3	cosΦ = 0.5	15,000	②	OKFC	220 V <sub>AC</sub>	10	cosΦ = 0.7	500,000	
	380 V <sub>AC</sub>	15	cosΦ = 1	10,000	②		110 V <sub>DC</sub>	0.5	L/R = 5	1,000,000	
		10	cosΦ = 1	200,000			80 V <sub>DC</sub>	1	L/R = 0	2,000,000	
		3 x 3.3	cosΦ = 0.8	200,000			48 V <sub>DC</sub>	5	L/R = 0	1,000,000	
	220 V <sub>AC</sub>	20	cosΦ = 1	20,000	②	OKSFC OKUIC	120 V <sub>DC</sub>	15	L/R = 0	100	②
		15	cosΦ = 0.5	20,000				8	L/R = 0	2,000,000	
		10	cosΦ = 1	400,000	6			L/R = 10	500,000	③	
		3 x 6	cosΦ = 0.8	200,000	3			L/R = 10	100,000	②	
		5	cosΦ = 1	1,500,000	1			L/R = 10	500,000		
		5	cosΦ = 1	3,000,000	80 V <sub>DC</sub>			25	L/R = 0	100	
		2.5	cosΦ = 0.25	2,000,000		15	L/R = 20	100			
		2	cosΦ = 1	15,000,000		10	L/R = 0	400,000			
		1.25	cosΦ = 1	30,000,000		7.5	L/R = 0	1,500,000			
		120 V <sub>DC</sub>	1.5	L/R = 0	550,000			5	L/R = 10	400,000	
48 V <sub>DC</sub>	10	L/R = 0	1,000,000								
	1.5	L/R = 5	18,000,000								
OKS	400 V <sub>DC</sub>	6	L/R = 10	100	③	OKSCd	400 V <sub>DC</sub>	6	L/R = 10	100	③
	250 V <sub>DC</sub>	15	L/R = 0	1,000	②		250 V <sub>DC</sub>	15	L/R = 0	1,000	②
		3	L/R = 20	300,000				3	L/R = 20	300,000	
		1	L/R = 10	30,000				1	L/R = 10	30,000	
		0.1	L/R = 15	3,500,000				1	L/R = 0	1,000,000	
	120 V <sub>DC</sub>	30	L/R = 0	100	③		120 V <sub>DC</sub>	20	L/R = 0	10,000	②
		20	L/R = 0	10,000				10	L/R = 10	1,000	
		10	L/R = 10	1,000	10			L/R = 0	300,000		
		10	L/R = 0	300,000	5			L/R = 10	60,000		
		5	L/R = 10	60,000	1			L/R = 40	500,000		
		2	L/R = 100	50,000	1			L/R = 10	1,000,000		
		1	L/R = 40	500,000	48 V <sub>DC</sub>			10	L/R = 0	2,600,000	
	1	L/R = 10	1,000,000	3			L/R = 30	400,000			
	48 V <sub>DC</sub>	10	L/R = 0	2,600,000			24 V <sub>DC</sub>	30	L/R = 50	200,000	④
1.5		L/R = 5	25,000,000								
24 V <sub>DC</sub>	30	L/R = 50	200,000	④							

Notes:

- ② 2 contacts connected in series
- ③ 3 contacts connected in series
- ② 2 contacts connected in parallel
- ③ 3 contacts connected in parallel
- ④ 4 contacts connected in parallel

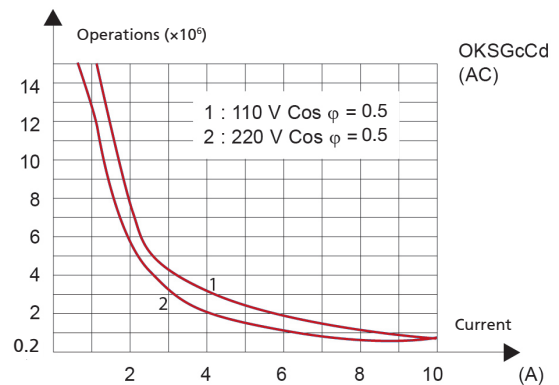
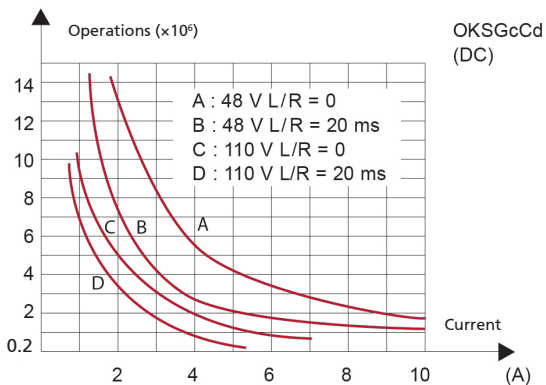
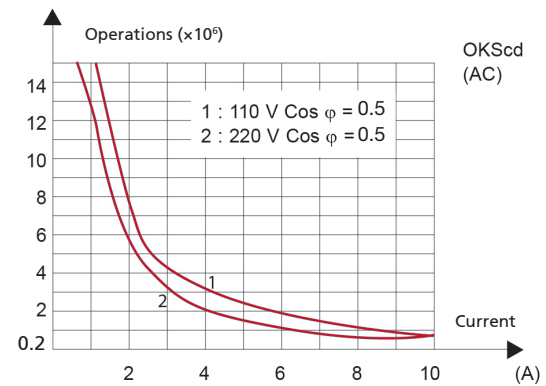
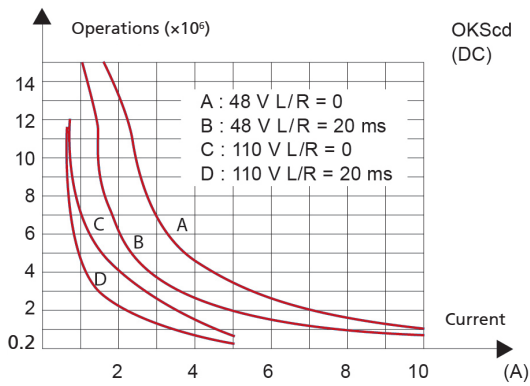
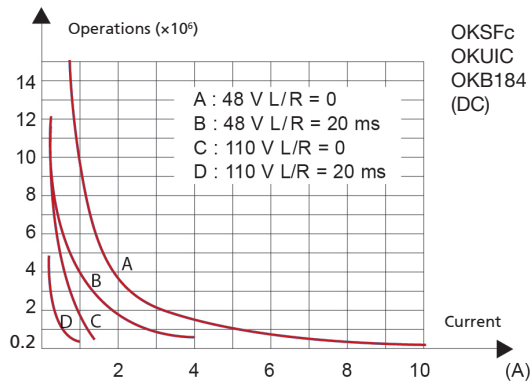
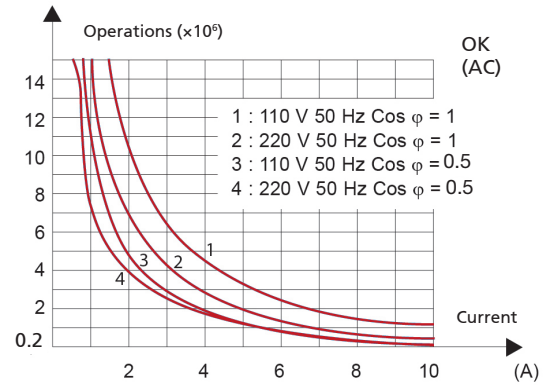
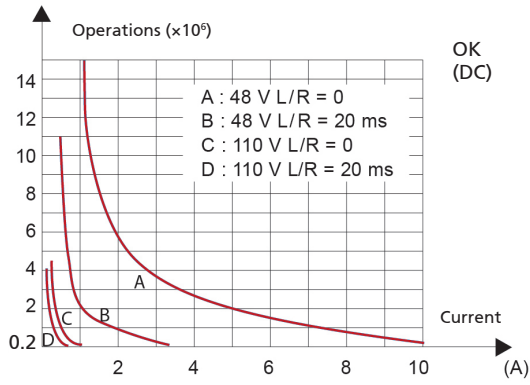

Switching frequency 1,200 operations / hour, 50 % cycle.

Sockets		OK series, 4 CO <sup>(1)</sup>
For wall or rail mounting		
Spring clamp, wall or DIN H35 rail mounting		PAIR160
Screw, wall or DIN H35 rail mounting		48BIP20-I DIN
Screw, wall mounting		48BL
Double faston, wall mounting		48L
For flush mounting		
Double faston (4.8 × 0.8 mm)		ADF2
Screw		43IL
For mounting on PCB		
		65

<sup>(1)</sup> For version with 8 and 12 contacts, assume two and three sockets respectively for each relay. In this instance, the mounting distance between centers of the sockets must be 45 mm. The ADF socket cannot be used. For more details, see specifications of mounting accessories.

Retaining clips - Correspondence with sockets	OK series - $V_{\text{supply}} = V_{\text{DC}}$	OK series - $V_{\text{supply}} = V_{\text{AC}}$ OKUIC	OKUIC with LED / VR / DIODE
Number of clips per relay	1, 2 for version with 8-12 CO contacts	1, 2 for version with 8-12 CO contacts and OKUIC	2
SOCKET MODEL	CLIP MODEL		
For wall or rail mounting			
PAIR160, 48BIP20-I DIN, 48BL, 48L	RC48	RL48	RC48
For flush mounting			
ADF2	RC48	RL48	RC48
43IL <sup>(1)</sup>	RC43	RL43	RC43
For mounting on PCB			
65	RC43	RL43	RC43

<sup>(1)</sup> Insert the clip before fastening the socket on the panel.

### Mounting tips

- The preferred mounting position is on the wall, with the relay positioned horizontally in the reading direction on the nameplate.
- For correct use of the relays, they should be spaced apart by at least 5 mm in the horizontal direction and 20 mm in the vertical direction. This is to allow correct upward dissipation of the heat generated by the coil. Set these distances according to the socket used. Distances can be reduced depending on the environmental application conditions and on the relay duty cycle.
- For safe and secure operation, it is advisable to use retaining clips.
- No special maintenance is required.
- Condensation can form inside the relay when powered up and the outside ambient temperature is cold; this is quite normal and does not affect the operation of the relay. The plastic materials of the relay do not possess hygroscopic properties.



RELAYS

## RAILWAY-APPROVED DOUBLE-BREAK MONOSTABLE RELAY

# F-OK B SERIES

### USER SECTORS



Power generation



Nuclear



Power transmission



Rolling stock



Fixed railway installations



Shipbuilding



Petroleum industry



Heavy industry

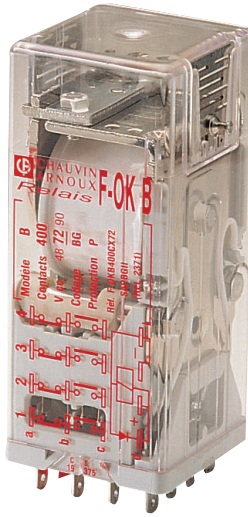

F-OK B

### PRODUCT ADVANTAGES

- Four double-break changeover contacts / 13 A
- NF-F 62002 railway certification
- High reliability for intensive use in harsh conditions
- Long-travel contacts and excellent break reliability

### DESCRIPTION

The relays in the **F-OK Series** are designed and manufactured with materials and solutions which make them particularly **long-lasting and rugged**. They are ideal for use in **difficult operating environments**, even in the event of significant thermal shocks. Thanks to their high resistance to **shocks and vibrations**, these relays are particularly suitable for use on rolling stock.

Because of the high electrical and mechanical performance provided by these relays, they can not only be used on rolling stock, but also in sectors such as **control and signaling** in railway transport or in applications with **continuous production processes**. Equipped with **“double break”** contacts, they are effective at **breaking DC loads**.

Models	Number of contacts	Nominal current
F-OK B	4	5 A

Coil specifications	F-OK B	F-OK B
Nominal voltages $U_n$ <sup>(1)</sup>	V <sub>DC</sub> : 24-36-48-72-96-110-125-550	V <sub>AC</sub> : 48-127-220
Maximum consumption at $U_n$ (DC/AC)	< 4.8 W	< 4.8 VA
Operating range <sup>(1)</sup>	<b>DC:</b> 70...125 % $U_n$	<b>AC:</b> 80...110 % $U_n$
Type of duty	Continuous	
Drop-out voltage <sup>(2)</sup>	> 10 % $U_n$	> 10 % $U_n$

<sup>(1)</sup> Other values on request. For ESAPOKS, values > 24 V.

<sup>(2)</sup> Limit value for supply voltage, expressed as % of the nominal value, beneath which the relay is certain to be de-energized.

Contact specifications		
Number and type	4 CO, Form Z	
Current	Nominal <sup>(1)</sup>	13 A
	Maximum pulse (10 ms) <sup>(2)</sup>	300 A for 10 ms
Maximum breaking voltage	350 V <sub>DC</sub>	
Contact material	AgNi AgCd010	
Contact closure pressure	> 0.3 N	
Contact opening pressure	> 0.3 N	
Contact closure time	DC	≤ 55 ms
	AC	≤ 55 ms
Contact opening time	DC	≤ 25 ms
	AC	≤ 25 ms

<sup>(1)</sup> On all contacts simultaneously, reduction of 30 %.

<sup>(2)</sup> The maximum peak and pulse currents are those currents that can be handled, for a specified time, by the contact. They do not refer to steady or interrupted currents.

Insulation		
Insulation resistance (at 500 V <sub>DC</sub> )	between the independent circuits and the ground	> 1,000 MΩ
	between open contact parts	> 1,000 MΩ
Withstand voltage at industrial frequency	between the independent circuits and the ground	2.5 kV (1 min)
	between open contact parts	2 kV (1 min)

Mechanical specifications		
Mechanical life expectancy	100 x 10 <sup>6</sup> operations	
Degree of protection (with relay mounted)	IP40	
Dimensions (mm) <sup>(1)</sup>	45 x 45 x 105	
Weight (g)	300	

<sup>(1)</sup> Excluding output terminals

Environmental specifications		
Operating temperature	Standard	(-13 to 158) °F (-25 to 70) °C
Storage and shipping temperature		(-40 to 158) °F (-40 to 70) °C
Relative humidity	Standard: 80 %	
Fire behavior	NF-F 16-101, NF-F 16-102, NF-F 62002	



## Standards and reference values

Resistance to vibrations (as per NF-F 62002)

Railway standards

2 g from 10 to 120 Hz (1 min)

NF-F 16-101, NF-F 16-102 (materials), NF-F 62002



## Ordering scheme - Please contact us

## Connection diagram and positive mechanical keying

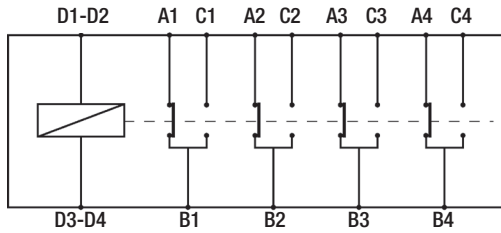

Coil voltage Keying position	Safety blank recess A	Safety blank recess B
220 V <sub>AC</sub>	C	G
24 V <sub>DC</sub>	A	G
36 V <sub>DC</sub>	F	L
48 V <sub>DC</sub>	D	G
72 V <sub>DC</sub>	B	G
72 V <sub>DC</sub> double winding	J	F
110 V <sub>DC</sub>	F	G
125 V <sub>DC</sub>	E	G
550 V <sub>DC</sub>	F	G

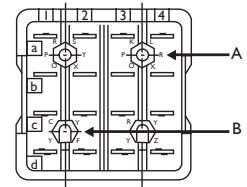

## Dimensions

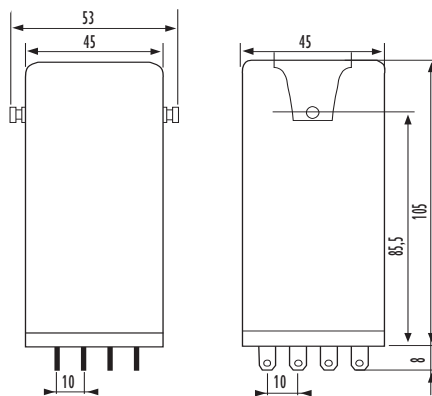

## Electrical life expectancy

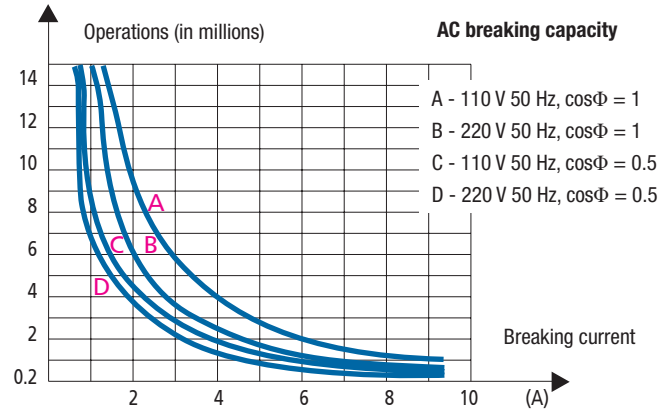
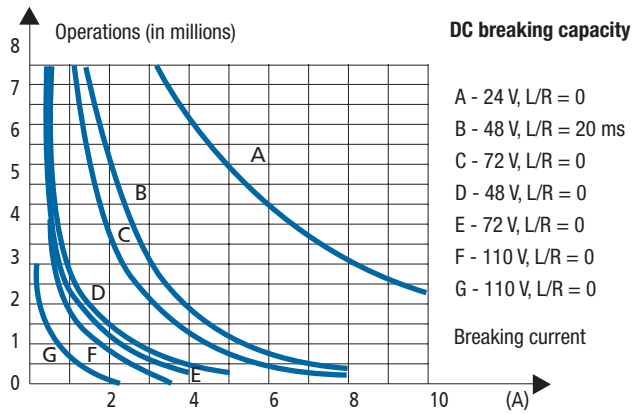

## Sockets and retaining clips

### F-OK B

Type of installation	Type of outputs	Model	Retaining clip
For flush mounting and DIN rail	Single faston	84F	Delivered with the socket

## Mounting tips

- The preferred mounting position is on the wall, with the relay positioned horizontally in the reading direction on the nameplate.
- For correct use of the relays, they should be spaced apart by at least 5 mm in the horizontal direction and 20 mm in the vertical direction. This is to allow correct upward dissipation of the heat generated by the coil. Set these distances according to the socket used. Distances can be reduced depending on the environmental application conditions and on the relay duty cycle.
- For safe and secure operation, it is advisable to use retaining clips.
- No special maintenance is required.
- Condensation can form inside the relay when powered up and the outside ambient temperature is cold; this is quite normal and does not affect the operation of the relay. The plastic materials of the relay do not possess hygroscopic properties.

# RELAYS

# RELAYS

# RELAYS

# RELAYS

# RELAYS

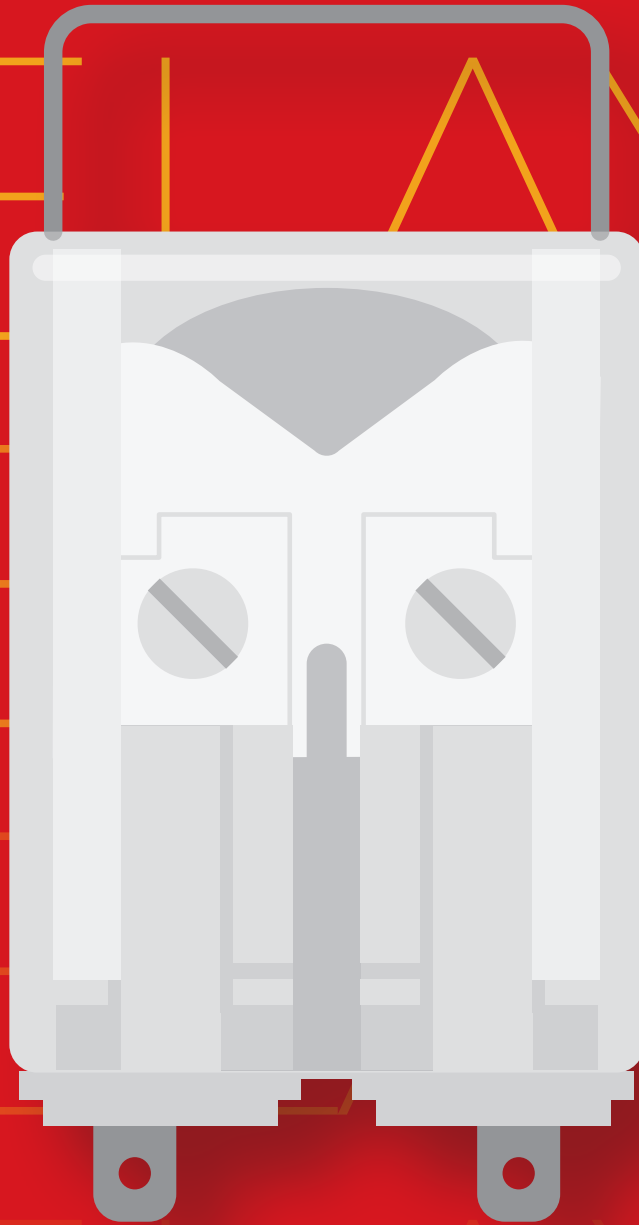

# INSTANTANEOUS MONOSTABLE RELAYS WITH FORCIBLY GUIDED CONTACTS

INSTANTANEOUS  
MONOSTABLE

INSTANTANEOUS  
MONOSTABLE WITH  
FORCIBLY GUIDED CONTACTS

TIME DELAY  
(ON PICK-UP  
OR DROP-OUT)

EXPLANATION OF  
SOCKET NUMBERING

FRONT  
CONNECTION

BACK  
CONNECTION

PCB MOUNT

RETAINING CLIPS

KEYING PINS



RELAYS

## INSTANTANEOUS RELAYS WITH 2-4 FORCIBLY GUIDED CONTACTS

# RCG | RDG SERIES with forcibly guided contacts

### USER SECTORS



Power generation



Nuclear



Power transmission



Rolling stock



Fixed railway installations



Shipbuilding



Petroleum industry



Heavy industry

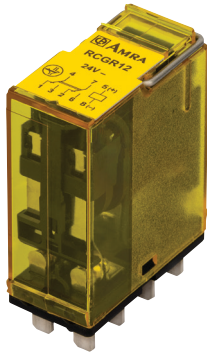

RCG



RDG

### PRODUCT ADVANTAGES

- Forcibly guided (mechanically linked) contacts, relay compliant with EN 61810-3, type A
- Weld-no-transfer technology
- Compact plug-in monostable instantaneous relay
- Suitable for safety applications
- Solid and rugged construction for heavy or intensive duty, IP50 protection
- Self-cleaning knurled contacts
- Long electrical life expectancy
- New "HIGH POWER" magnetic arc blow-out for improved breaking capacity, as option
- Wide range of options: LED indicating power on, FLYBACK DIODE
- Retaining clip for secure locking of relay on socket
- Transparent cover, pull-out handle

### DESCRIPTION

The relays in the RCG / RDG line are **highly reliable products** featuring high performance, suitable for applications in very harsh and disturbed environments. They are provided with forcibly guided (mechanically linked) contacts. The component conforms to the **EN 61810-3 requirements, type A** relay (all contacts are mechanically linked). Forcibly guided contacts are also known as weld-no-transfer contacts. A typical application is the check reading of a contact for determining, with absolute certainty, the state of the other contacts in self-monitoring control systems.

Thanks to the exceptional breaking capacity, the relay is suitable for controlling **heavy duty loads** with intensive switching frequency where safety and electrical continuity is an all-important factor.

The versatility in manufacture allows producing relays with various voltages.

The types of contacts allow obtaining remarkable performance levels both for high, inductive loads or very low loads; the optional presence of the **magnetic arc blow-out** contributes considerably to the **breaking capacity**. The knurled contacts ensure **better self-cleaning characteristics and lower ohm resistance** thanks to the various points of electrical connection, thereby improving the electrical life of the component.

In relays with forcibly guided (mechanically linked) or weld-no-transfer contacts, special design and constructional measures are used to ensure that make (normally-open) contacts can not assume the same state as break (normally-closed) contacts.

- If, when powering up a relay, a NC contact fails to open, the remaining NO contacts must not close, maintaining a contact gap  $\geq 0.5$  mm.
- When the relay is de-energized, if a NO contact fails to open, the remaining NC contact must not close, maintaining a contact gap  $\geq 0.5$  mm.

**EN 61810-3** lays down the standard requirements for relays with forcibly guided contacts. This standard defines two types of relay with forcibly guided contacts, namely:

- Type A: Relay whose contacts are all mechanically linked (forcibly guided).
- Type B: Relay containing mechanically linked contacts and contacts which are not mechanically linked.

In the case of relays that include changeover contacts, either the make circuit or the break circuit of a changeover contact can be considered to meet the requirements of this standard.

Models	Number of contacts	Magnetic arc blow-out	HIGH POWER Magnetic arc blow-out
RCG.x2	2		
RCG.x6	2	•	
RCG.x8	2		•
RDG.x2	4		
RDG.x6	4	•	
RDG.x8	4		•

**FOR CONFIGURATION OF PRODUCT CODE, SEE "ORDERING SCHEME" TABLE**

Coil specifications	RCG	RDG
Nominal voltages $U_n$ <sup>(1)</sup>	DC: 24-36-48-72-96-110-125	
Consumption at $U_n$	2.2 W	2.7 W
Operating range	80 - 115 % $U_n$	
Operating range for rolling stock version <sup>(2)</sup>	70 - 125 % $U_n$	
Type of duty	Continuous	
Drop-out voltage <sup>(3)</sup>	DC: > 5 % $U_n$	

<sup>(1)</sup> Other values on request.

<sup>(2)</sup> See "Ordering scheme" table for order code. Suitable for application on ROLLING STOCK. Operating range in accordance with EN60077.

<sup>(3)</sup> Limit value for supply voltage, expressed as % of the nominal value, beneath which the relay is certainly de-energized.

Contact specifications	RCG	RDG
Number and type	2 CO, form C	4 CO, form C
Current	See the following chart	
Nominal	13 A for 1 min - 20 A per 1 s	
Maximum peak <sup>(1)</sup>	100 A for 10 ms	
Maximum pulse <sup>(1)</sup>		
Example of electrical life expectancy <sup>(2)</sup>	Standard: RCG.x2 / RDG.x2: 0.2 A - 110 V <sub>DC</sub> - L/R 40 ms - 5 x 10 <sup>5</sup> operations *	
* 1,200 operations / hour	With Magnetic arc blowout: RCG.x6 / RDG.x6: 0.5 A - 110 V <sub>DC</sub> - L/R 40 ms - 1.5 x 10 <sup>5</sup> operations *	
** 600 operations / hour	With <b>HIGH POWER</b> Magnetic arc blowout: RCG.x8 / RDG.x8: 0.7 A - 132 V <sub>DC</sub> - L/R 40 ms - 7 x 10 <sup>4</sup> operations **	
Minimum load	Standard contacts: 100 mW (10 V, 5 mA)	
Gold-plated contact	50 mW (5 V, 5 mA)	
Making capacity	30 A - 110 V <sub>DC</sub> - L/R 0 ms: 2,000 operations	
Maximum breaking voltage	250 V <sub>DC</sub> / 300 V <sub>AC</sub>	
Contact material	AgSnO <sub>2</sub> (mobile contacts) - AgNi (fixed contacts)	
Operating time at $U_n$ (ms) <sup>(3)</sup>	Standard	With diode
Pick-up (NC contact opening)	≤ 13	≤ 13
Pick-up (NO contact closing)	≤ 19	≤ 19
Drop-out (NO contact opening)	≤ 4	≤ 11
Drop-out (NC contact closing)	≤ 16	≤ 25
	Standard	With diode
	≤ 17	≤ 17
	≤ 25	≤ 25
	≤ 4	≤ 20
	≤ 14	≤ 34

<sup>(1)</sup> The maximum peak and pulse currents are those currents that can be handled, for a specified time, by the contact. They do not refer to steady or interrupted currents.

<sup>(2)</sup> For other examples, see electrical life expectancy curves.

<sup>(3)</sup> Unless specified otherwise, the operating times refer to the stabilization of the contact (including bounces).

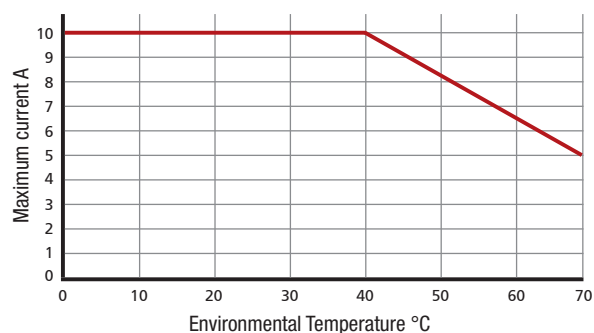

 <b>Insulation</b>	
Insulation resistance (at 500 V <sub>DC</sub> ) between electrically independent circuits and between these circuits and ground between open contact parts	> 1,000 MΩ > 1,000 MΩ
Dielectric withstanding voltage at industrial frequency between electrically independent circuits and ground between coil and contacts parts between open contact parts between adjacent contacts	4 kV (1 min) 3 kV (1 min) 2 kV (1 min) 3.5 kV (1 min)
Impulse withstand voltage (1.2/50 μs - 0.5 J) between electrically independent circuits and ground between open contact parts	5 kV 3 kV

 <b>Mechanical specifications</b>		
Mechanical life expectancy	20 x 10 <sup>6</sup> operations	
Maximum switching rate	Mechanical	3,600 operations / hour
Degree of protection (with relay mounted)	IP50	
Dimensions (mm) <sup>(1)</sup> Weight (g)	RCG	RDG
	40 x 20 x 50 60	40 x 40 50 115

<sup>(1)</sup> Excluding output terminals

 <b>Environmental specifications</b>	
Operating temperature	Standard (-13 to 131) °F (-25 to 55) °C Version for railways, rolling stock (-13 to 158) °F (-25 to 70) °C, (85 °C for 10 min), (-40 °C as option)
Storage and shipping temperature	(-40 to 185) °F (-40 to 85) °C
Relative humidity	Standard: 75 % RH, Tropicalized: 95 % RH
Fire behavior	V0

 <b>Standards and reference values</b>	
EN 61810-1, EN 61810-7 EN 61810-3, type A EN 60695-2-10 EN 60529 EN 61000-4	Electromechanical elementary relays Relays with forcibly guided (mechanically linked) contacts, type A Fire behavior Degree of protection provided by enclosures Electromagnetic compatibility

Unless otherwise specified, the products are designed and manufactured according to the requirements of the above-mentioned European and International standards. In accordance with EN 61810-1, all items of technical data are referred to ambient temperature 23 °C, atmospheric pressure 96 kPa and 50 % humidity. Tolerance for coil resistance, nominal electrical input and nominal power is ± 5 %.

 <b>Railways, rolling stock - Standards</b>	<b>Applicable to the RCGR and RDGR series</b>
EN 60077	Electric equipment for rolling stock — general service conditions and general rules
EN 50155	Electronic equipment used on rolling stock - T3 class
EN 61373 <sup>(1)</sup>	Shock and vibration tests, CAT 1, Class B
EN 45545-2	Fire behavior, HL3: CAT E10, Requirement R26, V0
ASTM E162, E662	Fire behavior

<sup>(1)</sup> Only for RDGR family: permissible opening time of contacts on a de-energized relay  $t < 100 \mu s$ .

## Configurations - Options

TROPICALIZATION	Surface treatment of coil with protective coating for use in conditions of RH 95 %. This treatment serves to give the coil added protection against corrosion that could occur as a result of moisture reacting with certain chemical agents such as those found in acid or saline atmospheres.
GOLD PLATING	Surface treatment of the contacts, blades and output terminals with gold-cobalt alloy $\geq 2 \mu$ . This treatment ensures long-term capacity of the contact to conduct lower currents.
LED	LED indicator showing presence of power supply. Flyback diode mounted as standard.
FLYBACK DIODE	Component connected in parallel to the coil (type BYW56) designed to dampen overvoltages generated by the coil when de-energized.
TRANSIL	Non-polarized component connected in parallel to the coil. Behavior is similar to that of a varistor with faster operating times.
LOW TEMPERATURE	Minimum operating temperature $-40 \text{ }^\circ\text{C}$ , only for rolling stock version (option "L").

## Ordering scheme

Product code	Application <sup>(1)</sup>	Configuration A	Configuration B	Label	Type of power supply	Nominal voltage (V) <sup>(2)</sup>	Finish <sup>(3)</sup>	Keying position <sup>(4)</sup>
RCG (2 contacts)	<b>E:</b> Energy <b>F:</b> Railway Fixed Equipment	1: Standard 2: Gold plating + Diode // + LED 3: Diode // 4: Gold plating	2: Standard 6: With magnetic arc blow-out 8: With <b>HIGH POWER</b> magnetic arc blow-out	F	C: V <sub>DC</sub>	024 - 036 048 - 072 096 - 110 - 125	<b>T:</b> Tropicalized coil  <b>L:</b> Low temperature	XX
RDG (4 contacts)	<b>R:</b> Railway Rolling Stock	6: Gold plating + Diode // 7: Diode // + LED 8: Transil						

Example	<b>RCG</b>	<b>E</b>	<b>4</b>	<b>2</b>	<b>F</b>	<b>C</b>	<b>048</b>		
	RCGE42F-C048 = ENERGY series relay with 2 CO gold-plated contacts, 48 V <sub>DC</sub> coil								
	<b>RDG</b>	<b>R</b>	<b>1</b>	<b>6</b>	<b>F</b>	<b>C</b>	<b>110</b>		
	RDGR16F-C110 = RAILWAY series relay, rolling stock, with 4 CO contacts, magnetic arc blow-out, 110 V <sub>DC</sub> coil								

<sup>(1)</sup> **E = ENERGY:** All applications, except for railway. Suitable on energy production, transport and distribution plants, railways fixed equipment, petrochemical and heavy industry.

**F = RAILWAYS, FIXED EQUIPMENT:** Application on fixed power systems and electrical railway traction. Construction according to RFI (FS Group, Italy) specification no. RFI DPRIM STF IFS TE143 A, if applicable. For the list of RFI approved and conforming products, consult dedicated catalog "RAILWAY SERIES - RFI APPROVED"

**R = RAILWAYS, ROLLING STOCK:** Application on board rolling stock (rail-tram-trolley vehicles). Electrical specifications according to EN 60077.

<sup>(2)</sup> Other values on request.

<sup>(3)</sup> Optional value.

<sup>(4)</sup> Optional value. The positive mechanical keying is applied according to the manufacturer's model.

## Wiring diagram

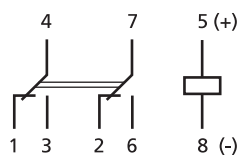

RCG

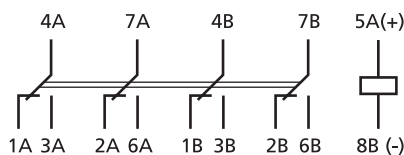

RDG

## Dimensions

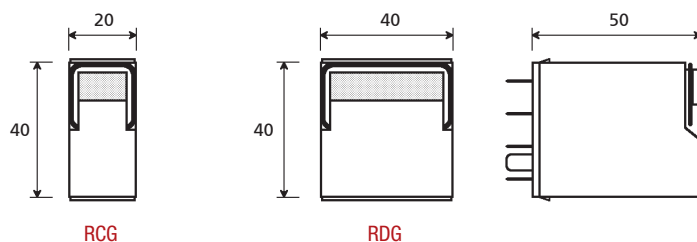

## Electrical life expectancy

Some examples of electrical life expectancy.

### RCG.12, RDG.12 (without magnetic arc blow-out)

U	I (A)	L/R (ms)	Operations
110 V <sub>DC</sub>	0.2	40	500,000
220 V <sub>DC</sub>	0.2	10	80,000
U	I (A)	cosΦ	Operations
110 V <sub>AC</sub>	1	1	1,200,000
110 V <sub>AC</sub>	1	0.5	1,000,000
110 V <sub>AC</sub>	5	1	500,000
110 V <sub>AC</sub>	5	0.5	300,000
220 V <sub>AC</sub>	0.5	1	1,200,000
220 V <sub>AC</sub>	1	0.5	500,000
220 V <sub>AC</sub>	5	1	400,000
220 V <sub>AC</sub>	5	0.5	300,000

### RCG.16, RDG.16 (with magnetic arc blow-out)

U	I (A)	L/R (ms)	Operations
110 V <sub>DC</sub>	0.2	40	1,000,000
110 V <sub>DC</sub>	0.5	40	150,000
110 V <sub>DC</sub>	0.6	10	300,000
110 V <sub>DC</sub>	1	10	100,000
220 V <sub>DC</sub>	0.2	10	100,000
U	I (A)	cosΦ	Operations
110 V <sub>AC</sub>	1	1	2,000,000
110 V <sub>AC</sub>	1	0.5	1,500,000
110 V <sub>AC</sub>	5	1	950,000
110 V <sub>AC</sub>	5	0.5	500,000
220 V <sub>AC</sub>	0.5	1	2,000,000
220 V <sub>AC</sub>	1	0.5	800,000
220 V <sub>AC</sub>	5	1	600,000
220 V <sub>AC</sub>	5	0.5	500,000

### RCG.16, RDG.16 (with magnetic arc blow-out)

U	I (A)	L/R (ms)	Operations
24 V <sub>DC</sub>	1	0	5,100,000
24 V <sub>DC</sub>	2	0	3,900,000
24 V <sub>DC</sub>	3	0	2,900,000
24 V <sub>DC</sub>	4	0	2,600,000
24 V <sub>DC</sub>	5	0	2,200,000
24 V <sub>DC</sub>	1	20	2,700,000
24 V <sub>DC</sub>	2	20	2,100,000
24 V <sub>DC</sub>	3	20	1,500,000
24 V <sub>DC</sub>	3.5	20	1,000,000
24 V <sub>DC</sub>	1	40	2,000,000
24 V <sub>DC</sub>	2	40	1,500,000
24 V <sub>DC</sub>	3	40	1,100,000
24 V <sub>DC</sub>	3.5	40	800,000
110 V <sub>DC</sub>	0.3	0	1,000,000
110 V <sub>DC</sub>	0.5	0	700,000
110 V <sub>DC</sub>	1	0	190,000
110 V <sub>DC</sub>	0.3	20	450,000
110 V <sub>DC</sub>	0.5	20	260,000
110 V <sub>DC</sub>	1	20	100,000
110 V <sub>DC</sub>	0.3	40	300,000
110 V <sub>DC</sub>	0.5	40	180,000
110 V <sub>DC</sub>	0.6	40	150,000
110 V <sub>DC</sub>	0.7	40	100,000
132 V <sub>DC</sub>	0.7	40	70,000

Switching frequency: 1,200 operations / hour.

Sockets and retaining clips		RCG	RDG	Retaining clip
Type of installation	Type of outputs	Model	Model	Retaining clip
Wall or DIN H35 rail mounting	Spring clamp	PAIR080	PAIR160	VM1831
	Screw	50IP20-I DIN	48BIP20-I DIN	VM1831
Flush mounting	Spring clamp	PRIR080	PRIR160	VM1831
	Double faston (4.8 × 0.8 mm)	ADF1	ADF2-BIPOK	VM1831
PCB-mount	Solder	65 <sup>(1)</sup>	65	VM1841

<sup>(1)</sup> Suitable for mounting 2 relays side by side.

### Mounting tips

- The preferred mounting position is on the wall, with the relay positioned horizontally in the reading direction on the nameplate.
- For correct use of the relays, they should be spaced apart by at least 5 mm in the horizontal direction and 20 mm in the vertical direction. This is to allow correct upward dissipation of the heat generated by the coil. Set these distances according to the socket used. Distances can be reduced depending on the environmental application conditions and on the relay duty cycle.
- For safe and secure operation, it is advisable to use retaining clips.
- No special maintenance is required.
- Condensation can form inside the relay when powered up and the outside ambient temperature is cold; this is quite normal and does not affect the operation of the relay. The plastic materials of the relay do not possess hygroscopic properties.



RELAYS

## INSTANTANEOUS RELAYS WITH 4 FORCIBLY GUIDED CONTACTS

# RGG SERIES with forcibly guided contacts

### USER SECTORS



Power generation



Nuclear



Power transmission



Rolling stock



Fixed railway installations



Shipbuilding



Petroleum industry



Heavy industry



RGG

### PRODUCT ADVANTAGES

- Forcibly guided (mechanically linked) contacts, relay compliant with EN 61810-3, type A
- Weld-no-transfer technology
- Plug-in monostable instantaneous relay
- Suitable for safety applications
- Solid and rugged construction for heavy or intensive duty
- Self-cleaning knurled contacts
- Very long electrical life expectancy and exceptional endurance
- Magnetic arc blow-out for higher breaking capacity
- Wide range of options: LED indicating power on, FLYBACK DIODE
- Retaining clip for secure locking of relay on socket
- Transparent cover, pull-out handle

### DESCRIPTION

The relays in the RGG line are **highly reliable products featuring high performance**, suitable for applications in very **harsh and disturbed environments**. They are provided with **forcibly guided** (mechanically linked) contacts. The component conforms to the **EN 61810-3** requirements, **type A relay** (all contacts are mechanically linked). Forcibly guided contacts are also known as weld-no-transfer contacts. A typical application is the check reading of a contact for determining, with absolute certainty, the state of the other contacts in self-monitoring control systems.

Thanks to the exceptional breaking capacity, the relay is suitable for controlling heavy duty loads with intensive switching frequency where safety and electrical continuity is an all-important factor.

The versatility in manufacture allows producing relays with any voltage in the range 12 to 230 V<sub>ac</sub> and with a great number of operating ranges adaptable to the various application requirements.

The types of contacts allow obtaining remarkable performance levels both for high, very inductive loads or very low loads; the optional presence of the **magnetic arc blow-out** contributes considerably to the **breaking capacity**. The knurled contacts ensure **better self-cleaning characteristics** and **lower ohmic resistance** thanks to the various points of electrical connection, thereby **improving the electrical life** of the component.

In relays with forcibly guided (mechanically linked) or weld-no-transfer contacts, special design and constructional measures are used to ensure that make (normally-open) contacts can not assume the same state as break (normally-closed) contacts.

- If, when powering up a relay, a NC contact fails to open, the remaining NO contacts must not close, maintaining a contact gap  $\geq 0.5$  mm.
- When the relay is de-energized, if a NO contact fails to open, the remaining NC contact must not close, maintaining a contact gap  $\geq 0.5$  mm.

**EN 61810-3** lays down the standard requirements for relays with forcibly guided contacts. This standard defines two types of relay with forcibly guided contacts, namely:

- Type A: Relay whose contacts are all mechanically linked (forcibly guided).
- Type B: Relay containing mechanically linked contacts and contacts which are not mechanically linked.

In the case of relays that include changeover contacts, either the make circuit or the break circuit of a changeover contact can be considered to meet the requirements of this standard.

Models	Number of contacts	Magnetic arc blow-out
RGG.x3X	4	
RGG.x7X	4	•

**FOR CONFIGURATION OF PRODUCT CODE, SEE "ORDERING SCHEME" TABLE**

Coil specifications	RGGExyX / RGGFxyX	RGGRxyX <sup>(2)</sup>
Nominal voltages $U_n$ <sup>(1)</sup>	DC: 12-24-48-110-125-132-144-230	DC: 24-36-72-110
Consumption at $U_n$ (DC/AC)	3.5 W	
Operating range	80 - 120 % $U_n$	70 - 125 % $U_n$
Type of duty	Continuous	
Drop-out voltage <sup>(3)</sup>	DC: > 5 % $U_n$	

<sup>(1)</sup> Other values on request.

<sup>(2)</sup> Suitable for application on ROLLING STOCK. Operating range in accordance with EN60077.

<sup>(3)</sup> Limit value for supply voltage, expressed as % of the nominal value, beneath which the relay is certainly de-energized.

Contact specifications														
	Number and type	4 CO, form C												
Current	Nominal <sup>(1)</sup>	12 A												
	Maximum peak <sup>(2)</sup>	20 A for 1 min — 40 A for 1 s												
	Maximum pulse <sup>(2)</sup>	150 A for 10 ms												
Example of electrical life expectancy <sup>(3)</sup>		RGG.x3: 0.5 A - 110 V <sub>DC</sub> - L/R 40 ms - 10 <sup>5</sup> operations - 1,800 operations / hour RGG.x7: 1 A - 110 V <sub>DC</sub> - L/R 40 ms - 10 <sup>5</sup> operations - 1,800 operations / hour 1 A - 110 V <sub>DC</sub> - L/R 40 ms - 2 x 10 <sup>5</sup> operations - 600 operations / hour												
Minimum load	Standard contacts	200 mW (10 V, 10 mA)												
	Gold-plated contact	50 mW (5 V, 5 mA)												
Maximum breaking voltage		350 V <sub>DC</sub> / 440 V <sub>AC</sub>												
Contact material		AgCdO												
Operating time at $U_n$ (ms) <sup>(4)</sup>		<table border="1"> <thead> <tr> <th>RGG.13X-17X-43X-47X</th> <th>RGG.33X-37X-63X-67X-53X-57X</th> </tr> </thead> <tbody> <tr> <td>DC</td> <td>DC</td> </tr> <tr> <td>Pick-up (NC contact opening)</td> <td>≤ 20</td> </tr> <tr> <td>Pick-up (NO contact closing)</td> <td>≤ 35</td> </tr> <tr> <td>Drop-out (NO contact opening)</td> <td>≤ 10</td> </tr> <tr> <td>Drop-out (NC contact closing)</td> <td>≤ 53</td> </tr> </tbody> </table>	RGG.13X-17X-43X-47X	RGG.33X-37X-63X-67X-53X-57X	DC	DC	Pick-up (NC contact opening)	≤ 20	Pick-up (NO contact closing)	≤ 35	Drop-out (NO contact opening)	≤ 10	Drop-out (NC contact closing)	≤ 53
	RGG.13X-17X-43X-47X	RGG.33X-37X-63X-67X-53X-57X												
	DC	DC												
	Pick-up (NC contact opening)	≤ 20												
	Pick-up (NO contact closing)	≤ 35												
Drop-out (NO contact opening)	≤ 10													
Drop-out (NC contact closing)	≤ 53													
	≤ 20													
	≤ 40													
	≤ 55													
	≤ 85													

<sup>(1)</sup> On all contacts simultaneously, reduction of 30 %.

<sup>(2)</sup> The maximum peak and pulse currents are those currents that can be handled, for a specified time, by the contact. They do not refer to steady or interrupted currents.

<sup>(3)</sup> For other examples, see electrical life expectancy curves.

<sup>(4)</sup> Unless specified otherwise, the operating times refer to the stabilization of the contact (including bounces).

Insulation	
Insulation resistance (at 500 V <sub>DC</sub> ) between electrically independent circuits and between these circuits and ground between open contact parts	> 10,000 MΩ > 10,000 MΩ
Withstand voltage at industrial frequency between electrically independent circuits and between these circuits and ground between open contact parts between adjacent contacts	2 kV (1 min) - 2.2 kV (1 s) 2 kV (1 min) - 2.2 kV (1 s) 2 kV (1 min) - 2.2 kV (1 s)
Impulse withstand voltage (1.2/50 μs - 0.5 J) between electrically independent circuits and between these circuits and ground between open contact parts	5 kV 4 kV

## Mechanical specifications

	Mechanical life expectancy	10 x 10 <sup>6</sup> operations
Maximum switching rate	Mechanical	3,600 operations / hour
	Degree of protection (with relay mounted)	IP40
	Dimensions (mm) <sup>(1)</sup>	50 x 50 x 86
	Weight (g)	280

<sup>(1)</sup> Excluding output terminals

## Environmental specifications

Operating temperature	Standard	(-13 to 131) °F (-25 to 55) °C
	Version for railways, rolling stock	(-13 to 158) °F (-25 to 70) °C, (85 °C for 10 min), (-40 °C as option)
Storage and shipping temperature		(-58 to 185) °F (-50 to 85) °C
Relative humidity		Standard: 75 % RH, Tropicalized: 95 % RH
Fire behavior		V0

## Standards and reference values

EN 61810-1, EN 61810-2, EN 61810-7	Electromechanical elementary relays
EN 61810-3, type A	Relays with forcibly guided (mechanically linked) contacts, type A
EN 60695-2-10	Fire behavior
EN 60529	Degree of protection provided by enclosures
EN 61000	Electromagnetic compatibility

Unless otherwise specified, the products are designed and manufactured according to the requirements of the above-mentioned European and International standards. In accordance with EN 61810-1, all items of technical data are referred to ambient temperature 23 °C, atmospheric pressure 96 kPa and 50 % humidity. Tolerance for coil resistance, nominal electrical input and nominal power is ± 5 %.

## Railways, rolling stock - Standards

### Applicable to RGGRX version

EN 60077	Electric equipment for rolling stock — general service conditions and general rules
EN 61373 <sup>(1)</sup>	Shock and vibration tests, CAT 1, Class B
EN 45545-2	Fire behavior, CAT E10, Requirement R26, V0
ASTM E162, E662	Fire behavior

<sup>(1)</sup> Permissible opening time of contacts on a de-energized relay  $t < 3$  ms

## Railways, rolling stock - Special operating ranges

Nominal voltage	Minimum pick-up voltage	Maximum operating voltage	Order symbol <sup>(1)</sup>
24 V <sub>dc</sub>	16.8	32	Z01
36 V <sub>dc</sub>	23	42.5	Z01
72 V <sub>dc</sub>	55	96	Z01
110 V <sub>dc</sub>	77	144	Z01

<sup>(1)</sup> To order the relay with the special operating range, indicate the “Z0x” symbol in the “Keying position” field of the ordering scheme. The special range may be subject to operating specifications different from standard specifications. Please contact us for further information.

## Configurations - Options

TROPICALIZATION	Surface treatment of the coil with protective coating for use with RH 95 %.
GOLD PLATING	Surface treatment of the contacts, blades and output terminals with gold-cobalt alloy $\geq 2 \mu$ . This treatment ensures long-term capacity of the contact to conduct lower currents.
LED	LED indicator showing presence of power supply, wired in parallel with the coil.
FLYBACK DIODE	Component connected in parallel to the coil (type 1N4007) designed to dampen overvoltages generated by the coil when de-energized.
TRANSIL	Non-polarized component connected in parallel to the coil. Behavior is similar to that of a varistor with faster operating times.
LOW TEMPERATURE	Minimum operating temperature -50 °C, only for rolling stock version (option “L”).

## Ordering scheme

Product code	Application <sup>(1)</sup>	Configuration A	Configuration B	Label	Type of power supply	Nominal voltage (V) <sup>(2)</sup>	Finish <sup>(3)</sup>
RGG	<b>E:</b> Energy <b>F:</b> Railway Fixed Equipment <b>R:</b> Railway Rolling Stock	1: Standard 2: Gold plating + Diode // + LED 3: Diode // 4: Gold plating 5: LED 6: Gold plating + Diode // 7: Diode // + LED 8: Transil 9: Transil + LED 0: Gold plating + Transil + LED	3X: 4 CO contacts 7X: 4 CO contacts with magnetic arc blow-out	F	C: V <sub>dc</sub>	012 - 024 - 036 048 - 072 - 110 125 - 132 - 144 220	Z0x: Special operating range (only for "R" applications) T: Tropicalized coil L: Low temperature

Example	<b>RGG</b>	<b>E</b>	<b>3</b>	<b>7X</b>	<b>F</b>	<b>C</b>	<b>048</b>	<b>T</b>
	RGGE37XF-C048/T = ENERGY series relay with flyback diode, magnetic arc blow-out and 48 V <sub>dc</sub> tropicalized coil.							
	<b>RGG</b>	<b>F</b>	<b>5</b>	<b>3X</b>	<b>F</b>	<b>C</b>	<b>110</b>	
	RGGF53XF-C110 = RAILWAY series relay, fixed equipment, with LED indicator and 110 V <sub>dc</sub> coil.							

<sup>(1)</sup> **E = ENERGY:** All applications, except for railway. Suitable on energy production, transport and distribution plants, railways fixed equipment, petrochemical and heavy industry.

**F = RAILWAYS, FIXED EQUIPMENT:** Application on fixed power systems and electrical railway traction. Construction according to RFI (FS Group, Italy) specification no. RFI DPRIM STF IFS TE143 A, if applicable. For the list of RFI approved and conforming products, consult dedicated catalog "RAILWAY SERIES - RFI APPROVED"

**R = RAILWAYS, ROLLING STOCK:** Application on board rolling stock (rail-tram-trolley vehicles). Electrical specifications according to EN 60077.

<sup>(2)</sup> Other values on request.

<sup>(3)</sup> Optional value: multiple selection possible (e.g. T-L).

## Wiring diagram

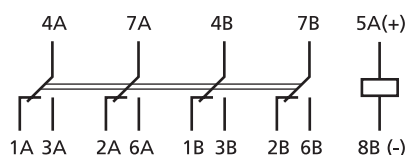

## Dimensions

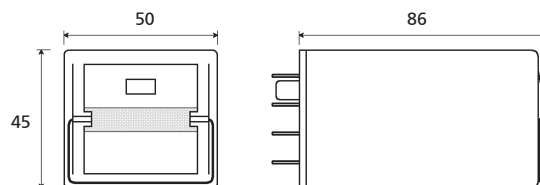

Some examples of electrical life expectancy

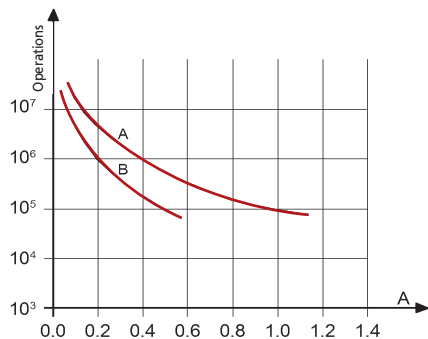

Contact loading: 110 V<sub>DC</sub>, L/R 40 ms

Curve A: RGG\_x7X

Curve B: RGG\_x3X

RGG.x3X			
U	I (A)	L/R (ms)	Operations
110 V <sub>DC</sub>	0.5	40	100,000
110 V <sub>DC</sub>	0.6	10	300,000
120 V <sub>DC</sub>	0.7	40	50,000
125 V <sub>DC</sub>	1.2	0	1,000,000
220 V <sub>DC</sub>	0.1	40	100,000
220 V <sub>DC</sub>	0.25	10	100,000
U	I (A)	cosΦ	Operations
110 V <sub>AC</sub>	1	1	2,000,000
110 V <sub>AC</sub>	1	0.5	1,500,000
110 V <sub>AC</sub>	5	1	1,000,000
110 V <sub>AC</sub>	5	0.5	500,000
220 V <sub>AC</sub>	0.5	1	2,000,000
220 V <sub>AC</sub>	1	0.5	600,000
220 V <sub>AC</sub>	5	1	650,000
220 V <sub>AC</sub>	5	0.5	600,000

RGG.x7X			
U	I (A)	L/R (ms)	Operations
24 V <sub>DC</sub>	1	0	7,000,000
24 V <sub>DC</sub>	1	40	3,000,000
24 V <sub>DC</sub>	2	40	2,000,000
24 V <sub>DC</sub>	5	0	3,000,000
24 V <sub>DC</sub>	5	40	200,000
24 V <sub>DC</sub>	9	0	800,000
U	I (A)	cosΦ	Operations
48 V <sub>DC</sub>	5	20	200,000
110 V <sub>DC</sub>	0.4	40	1,000,000
110 V <sub>DC</sub>	1	40	200,000 <sup>(1)</sup>
110 V <sub>DC</sub>	10	0	100,000
U	I (A)	cosΦ	Operations
220 V <sub>AC</sub>	5	0.5	100,000
220 V <sub>AC</sub>	10	1	100,000
230 V <sub>AC</sub>	1	0.7	2,500,000
230 V <sub>AC</sub>	3	0.7	1,200,000

Switching frequency: 1,200 operations / hour

<sup>(1)</sup> 600 operations / hour

Sockets and retaining clips

Type of installation	Type of outputs	Model	Retaining clip
Wall or DIN rail mounting	Screw	48BIP20-I DIN	RG48
	Spring clamp	PAIR160	
Flush mounting	Screw	43IL	RG43
	Spring clamp	PRIR160	RG48
	Double faston (4.8 × 0.8 mm)	ADF2	

Mounting tips

- The preferred mounting position is on the wall, with the relay positioned horizontally in the reading direction on the nameplate.
- For correct use of the relays, they should be spaced apart by at least 5 mm in the horizontal direction and 20 mm in the vertical direction. This is to allow correct upward dissipation of the heat generated by the coil. Set these distances according to the socket used. Distances can be reduced depending on the environmental application conditions and on the relay duty cycle.
- For safe and secure operation, it is advisable to use retaining clips.
- No special maintenance is required.
- Condensation can form inside the relay when powered up and the outside ambient temperature is cold; this is quite normal and does not affect the operation of the relay. The plastic materials of the relay do not possess hygroscopic properties.





RELAYS

## INSTANTANEOUS RELAYS WITH 8 FORCIBLY GUIDED CONTACTS

**RMGX SERIES** with forcibly guided contacts

## USER SECTORS



Power generation



Nuclear



Power transmission



Rolling stock



Fixed railway installations



Shipbuilding



Petroleum industry



Heavy industry



RMGR16X\_3

**PRODUCT ADVANTAGES**

- Mechanically linked contacts, relay compliant with IEC **EN 61810-3, type A**
- Weld-no-transfer technology
- Plug-in monostable instantaneous relay
- Suitable for safety applications
- Solid and rugged construction for heavy or intensive duty
- Self-cleaning knurled contacts
- Very long electrical life expectancy and exceptional endurance
- Magnetic arc blow-out (optional) for higher breaking capacity
- Wide range of options: LED indicating power on, FLYBACK DIODE
- Transparent cover, with access for manual operation (standard) and pull-out handle
- Retaining clip for secure locking of relay on socket

**DESCRIPTION**

**RMGX relays** are highly reliable products offering top performance, suitable for applications in particularly harsh and unsettled environments. Meeting the requirements of standard **EN 61810-3 type A**; the relay is equipped with mechanically linked contacts (forcibly guided), an indispensable feature for applications where there is a need to guarantee that make (NO) contacts will never assume the same status as break (NC) contacts. Forcibly guided contacts are also known as weld-no-transfer contacts. With change-over contacts, customers have the greatest possible flexibility in selecting the configuration (6 NC + 2 NO, 5 NC + 3 NO, etc.) best suited to their particular needs.

Thanks to its exceptional breaking capacity, the relay is suitable for **controlling heavy duty loads with intensive switching frequency**, where safety and continuity of operation are all-important. Manual operation as standard for all models, allowing tests to be conducted in the absence of any power supply. The contacts used are of a type designed to give top performance both with high and strongly inductive DC loads, and with particularly low loads; inclusion of the magnetic arc blow-out function (optional) helps to achieve a considerable increase in breaking capacity.

**Knurled contacts** ensure not only better **self-cleaning** characteristics, but also lower ohmic resistance thanks to multiple points of electrical connection, thereby extending the electrical life expectancy of the component.

In relays with forcibly guided (mechanically linked) or weld-no-transfer contacts, special design and constructional measures are used to ensure that make (normally-open) contacts can not assume the same state as break (normally-closed) contacts.

- If, when powering up a relay, a NC contact fails to open, the remaining NO contacts must not close, maintaining a contact gap  $\geq 0.5$  mm.
- When the relay is de-energized, if a NO contact fails to open, the remaining NC contact must not close, maintaining a contact gap  $\geq 0.5$  mm.

**EN 61810-3** lays down the standard requirements for relays with forcibly guided contacts. This standard defines two types of relay with forcibly guided contacts, namely:

- Type A: Relay whose contacts are all mechanically linked (forcibly guided).
- Type B: Relay containing mechanically linked contacts and contacts which are not mechanically linked.

In the case of relays that include changeover contacts, either the make circuit or the break circuit of a changeover contact can be considered to meet the requirements of this standard.

Models	Number of contacts	Magnetic arc blow-out
RMG.x2X	6 CO + 2 NC	
RMG.x6X	6 CO + 2 NC	•

**FOR CONFIGURATION OF PRODUCT CODE, SEE "ORDERING SCHEME" TABLE**

Coil specifications	RMGExyX - RMGFxyX	RMGRxyX <sup>(2)</sup>
Nominal voltages $U_n$ <sup>(1)</sup>	DC: 24-48-110-125-132-220	DC: 24-36-72-96-110
Consumption at $U_n$ (DC/AC)	3 W	
Operating range	80 - 120 % $U_n$	70 - 125 % $U_n$
Type of duty	Continuous	
Drop-out voltage <sup>(3)</sup>	DC: > 5 % $U_n$	

<sup>(1)</sup> Other values on request.

<sup>(2)</sup> Suitable for application on ROLLING STOCK. Operating range in accordance with EN60077.

<sup>(3)</sup> Limit value for supply voltage, expressed as % of the nominal value, beneath which the relay is certainly de-energized.

Contact specifications		
	Number and type	6 CO + 2 NA, form C
Current	Nominal	See following graph
	Maximum peak <sup>(1)</sup>	20 A for 1 min - 40 A for 1 s
	Maximum pulse <sup>(1)</sup>	150 A for 10 ms
Example of electrical life expectancy <sup>(3)</sup>		RMG.x2X: 0.5 A - 110 V <sub>DC</sub> - L/R 40 ms - 10 <sup>5</sup> operations - 1,800 operations / hour RMG.x6X: 1 A - 110 V <sub>DC</sub> - L/R 40 ms - 10 <sup>5</sup> operations - 1,800 operations / hour
Minimum load	Standard contacts	200 mW (10 V, 10 mA)
	Gold-plated contact	50 mW (5 V, 5 mA)
Maximum breaking voltage		350 V <sub>DC</sub> / 440 V <sub>AC</sub>
Contact material		AgCdO
Operating time at $U_n$ (ms) <sup>(2)</sup>		DC
	Pick-up (NC contact opening)	≤ 35
	Pick-up (NO contact closing)	≤ 60
	Drop-out (NO contact opening)	≤ 4
	Drop-out (NC contact closing)	≤ 45

<sup>(1)</sup> The maximum peak and pulse currents are those currents that can be handled, for a specified time, by the contact. They do not refer to steady or interrupted currents.

<sup>(2)</sup> Unless specified otherwise, the operating times refer to the stabilization of the contact (including bounces).

## Rated current contact

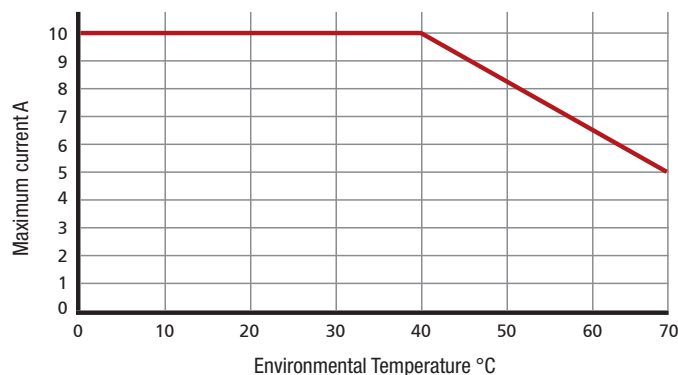



Note: reduction of 30 % on all the contacts simultaneously.

 <b>Insulation</b>	
Insulation resistance (at 500 V <sub>DC</sub> ) between electrically independent circuits and between these circuits and ground between open contact parts	> 10,000 MΩ > 10,000 MΩ
Withstand voltage at industrial frequency between electrically independent circuits and between these circuits and ground between open contact parts between adjacent contacts	2 kV (1 min) - 2.2 kV (1 s) 2 kV (1 min) - 2.2 kV (1 s) 2 kV (1 min) - 2.2 kV (1 s)
Impulse withstand voltage (1.2/50 μs - 0.5 J) between electrically independent circuits and between these circuits and ground between open contact parts	5 kV 5 kV

 <b>Mechanical specifications</b>	
Mechanical life expectancy	10 x 10 <sup>6</sup> operations
Maximum switching rate	Mechanical 3,600 operations / hour
Degree of protection	IP50 fitted to socket
Dimensions (mm) <sup>(1)</sup>	45 x 90 x 100
Weight (g)	280

<sup>(1)</sup> Excluding output terminals

 <b>Environmental specifications</b>	
Operating temperature	Standard (-13 to 131) °F (-25 to 55) °C Version for railways, rolling stock (-13 to 158) °F (-25 to 70) °C, (85 °C for 10 min), (-40 °C as option)
Storage and shipping temperature	(-13 to 185) °F (-25 to 85) °C
Relative humidity	Standard: 75 % RH, Tropicalized: 95 % RH
Fire behavior	V0

 <b>Standards and reference values</b>	
EN 61810-1, EN 61810-2, EN 61810-7 EN 61810-3, type A EN 60695-2-10 EN 60529	All-or-nothing relays Relays with forcibly guided (mechanically linked) contacts, type A Fire behavior Degree of protection provided by enclosures

Unless otherwise specified, the products are designed and manufactured according to the requirements of the above-mentioned European and International standards. In accordance with EN 61810-1, all items of technical data are referred to ambient temperature 23 °C, atmospheric pressure 96 kPa and 50 % humidity. Tolerance for coil resistance, nominal electrical input and nominal power is ± 7 %.

 <b>Railways, rolling stock - Standards</b>	<b>Applicable to RMGRX version</b>
EN 60077 EN 61373 <sup>(1)</sup> EN 45545-2 ASTM E162, E662	Electric equipment for rolling stock — general service conditions and general rules Shock and vibration tests, CAT 1, Class B Fire behavior, CAT E10, Requirement R26, V0 Fire behavior

<sup>(1)</sup> Opening of NC contacts allowed only at de-energized relay t < 3 ms

 <b>Configurations - Options</b>	
TROPICALIZATION	Surface treatment of the coil with protective coating for use with RH 95 %.
GOLD PLATING	Surface treatment of the contacts, blades and output terminals with gold-cobalt alloy ≥ 2 μ. This treatment ensures long-term capacity of the contact to conduct lower currents.
LED	LED indicator showing presence of power supply, wired in parallel with the coil.
FLYBACK DIODE	Component connected in parallel to the coil (type 1N4007) designed to dampen overvoltages generated by the coil when de-energized.
TRANSIL	Non-polarized component connected in parallel to the coil. Behavior is similar to that of a varistor with faster operating times.
LOW TEMPERATURE	Minimum operating temperature -50 °C, only for rolling stock version (option "L").



## Ordering scheme

Product code	Application <sup>(1)</sup>	Configuration A	Configuration B	Label	Type of power supply	Nominal voltage (V) <sup>(2)</sup>	Finish <sup>(3)</sup>	Keying position <sup>(4)</sup>
RMG	<b>E:</b> Energy <b>F:</b> Railway Fixed Equipment <b>R:</b> Railway Rolling Stock	1: Standard 2: Gold plating + Diode // + LED 3: Diode // 4: Gold plating 5: LED 6: Gold plating + Diode // 7: Diode // + LED	2X: 6 CO contacts + 2 NO 6X: 6 CO contacts + 2 NO with magnetic arc blow-out	F	C: V <sub>DC</sub>	024 - 036 - 048 072 - 096 - 110 125 - 132 - 220	<b>T:</b> Tropicalized coil  <b>L:</b> Low temperature	XX

Example	<b>RMG</b>	<b>E</b>	<b>3</b>	<b>6X</b>	<b>F</b>	<b>C</b>	<b>048</b>	<b>T</b>	
	RMGE36XF-C048/T = ENERGY series relay with back EMF suppression diode, magnetic arc blow-out and 48 V <sub>DC</sub> tropicalized coil.								
	<b>RMG</b>	<b>R</b>	<b>7</b>	<b>2X</b>	<b>F</b>	<b>C</b>	<b>110</b>		
	RMGR72XF-C110 = RAILWAY series relay, equipped with flyback diode and indicator LED and 110 V <sub>DC</sub> coil.								

<sup>(1)</sup> **E = ENERGY:** All applications, except for railway. Suitable on energy production, transport and distribution plants, railways fixed equipment, petrochemical and heavy industry.

**F = RAILWAYS, FIXED EQUIPMENT:** Application on fixed power systems and electrical railway traction. Construction according to RFI (FS Group, Italy) specification no. RFI DPRIM STF IFS TE143 A, if applicable. For the list of RFI approved and conforming products, consult dedicated catalog "RAILWAY SERIES - RFI APPROVED"

**R = RAILWAYS, ROLLING STOCK:** Application on board rolling stock (rail-tram-trolley vehicles). Electrical specifications according to EN 60077.

<sup>(2)</sup> Other values on request.

<sup>(3)</sup> Optional value.

<sup>(4)</sup> Optional value. The positive mechanical keying is applied according to the manufacturer's model.

## Wiring diagram

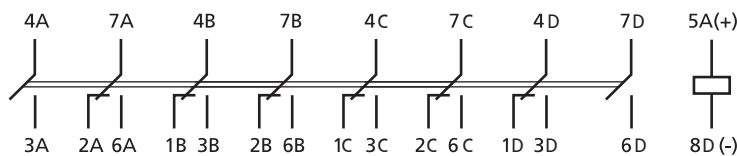

## Dimensions

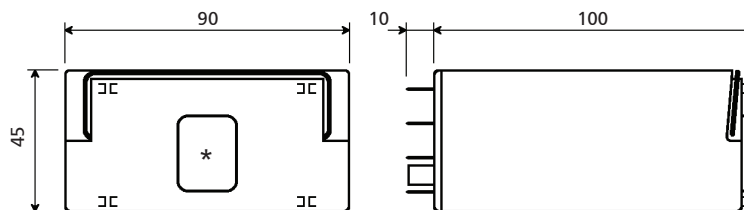

(\*) access to the manual operating lever.

## Electrical life expectancy

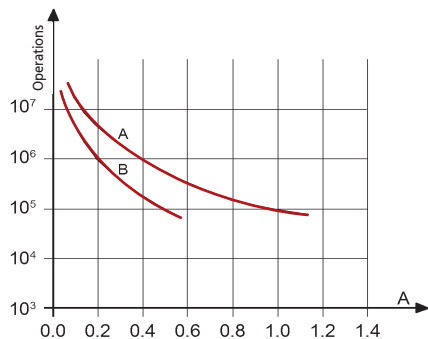

Contact loading: 110 V<sub>DC</sub>, L/R 40 ms

Curve A: RMG.x6X

Curve B: RMG.x2X

RMG.x2X			
U	I (A)	L/R (ms)	Operations
110 V <sub>DC</sub>	0.5	40	100,000
110 V <sub>DC</sub>	0.6	10	300,000
120 V <sub>DC</sub>	0.7	40	50,000
125 V <sub>DC</sub>	1.2	0	1,000,000
220 V <sub>DC</sub>	0.1	40	100,000
220 V <sub>DC</sub>	0.25	10	100,000
U	I (A)	cosΦ	Operations
110 V <sub>AC</sub>	1	1	2,000,000
110 V <sub>AC</sub>	1	0.5	1,500,000
110 V <sub>AC</sub>	5	1	1,000,000
110 V <sub>AC</sub>	5	0.5	500,000
220 V <sub>AC</sub>	0.5	1	2,000,000
220 V <sub>AC</sub>	1	0.5	600,000
220 V <sub>AC</sub>	5	1	650,000
220 V <sub>AC</sub>	5	0.5	600,000

RGG.x7X			
U	I (A)	L/R (ms)	Operations
24 V <sub>DC</sub>	1	0	7,000,000
24 V <sub>DC</sub>	1	40	3,000,000
24 V <sub>DC</sub>	2	40	2,000,000
24 V <sub>DC</sub>	5	0	3,000,000
24 V <sub>DC</sub>	5	40	200,000
24 V <sub>DC</sub>	9	0	800,000
48 V <sub>DC</sub>	5	20	200,000
110 V <sub>DC</sub>	0.4	40	1,000,000
110 V <sub>DC</sub>	1	40	200,000
110 V <sub>DC</sub>	10	0	100,000
U	I (A)	cosΦ	Operations
220 V <sub>AC</sub>	5	0.5	100,000
220 V <sub>AC</sub>	10	1	100,000
230 V <sub>AC</sub>	1	0.7	2,500,000
230 V <sub>AC</sub>	3	0.7	1,200,000

Switching frequency: 1,200 operations / hour

## Sockets and retaining clips

Type of installation	Type of outputs	Model	Retaining clip
Wall or DIN rail mounting	Screw	96IP20-I DIN	RG48
	Spring clamp	PAIR320	
Flush mounting	Double faston (4.8 × 0.8 mm)	ADF4-E1	
	Spring clamp	PRIR321	

## Mounting tips

- The preferred mounting position is on the wall, with the relay positioned horizontally in the reading direction on the nameplate.
- For correct use of the relays, they should be spaced apart by at least 5 mm in the horizontal direction and 20 mm in the vertical direction. This is to allow correct upward dissipation of the heat generated by the coil. Set these distances according to the socket used. Distances can be reduced depending on the environmental application conditions and on the relay duty cycle.
- For safe and secure operation, it is advisable to use retaining clips.
- No special maintenance is required.
- Condensation can form inside the relay when powered up and the outside ambient temperature is cold; this is quite normal and does not affect the operation of the relay. The plastic materials of the relay do not possess hygroscopic properties.



RELAYS

RELAYS

RELAYS

RELAYS

RELAYS

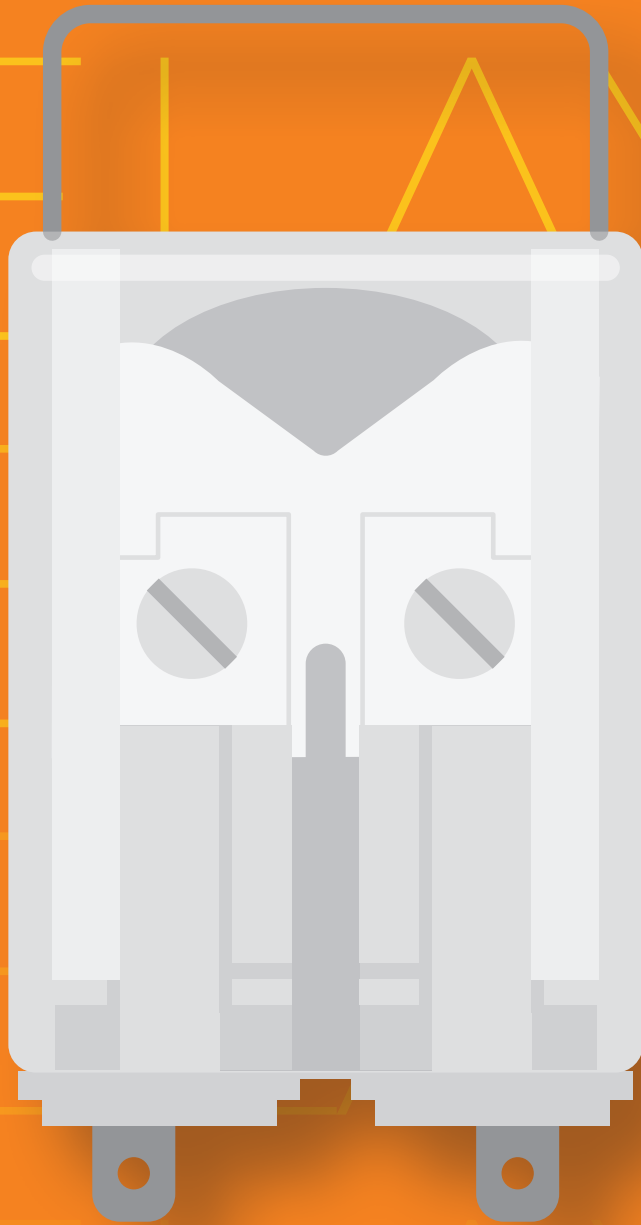

# TIME DELAY RELAYS (ON PICK-UP OR DROP-OUT), LOGIC FUNCTION

INSTANTANEOUS  
MONOSTABLE

INSTANTANEOUS  
MONOSTABLE WITH  
FORCIBLY GUIDED CONTACTS

TIME DELAY  
(ON PICK-UP  
OR DROP-OUT)

EXPLANATION OF  
SOCKET NUMBERING

FRONT  
CONNECTION

BACK  
CONNECTION

PCB MOUNT

RETAINING CLIPS

KEYING PINS



RELAYS

## MULTIFUNCTION MULTISCALE TIMER DELAY WITH 4 CONTACTS

# TMM SERIES

### USER SECTORS



Power generation



Nuclear



Power transmission



Rolling stock



Fixed railway installations



Shipbuilding



Petroleum industry



Heavy industry

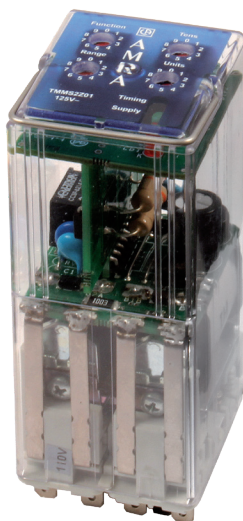

TMM

### PRODUCT ADVANTAGES

- Plug-in relay with time delay, multifunction
- Ten different time delay functions
- Four time delay contacts or two time delay contacts + two instantaneous contacts
- Wide time setting range from 0.1 seconds to 99 hours, extreme accuracy across the adjustment range
- High electromagnetic interference immunity
- Solid and rugged construction for heavy or intensive duty
- Long life expectancy
- Independent and self-cleaning contacts
- Magnetic arc blow-out standard
- Separate arc breaking chambers
- Excellent shock and vibration resistance
- Wide range of sockets
- Wide variety of configurations and customizations
- Retaining clip for secure locking of relay on socket
- Transparent cover, pull-out handle
- Positive mechanical keying for relay and socket

### DESCRIPTION

The **TMM series** is a range of multifunction relays with electronic time delay, consisting of two models with four change-over contacts, rated 10 A (nominal). They are obtained by assembling the electromechanical units of the POKS series with a digital electronic circuit. The electromechanical part features the **reliability and ruggedness of relays belonging to the POKS series**, while the electronics offers high reliability thanks to the use of a circuit requiring few components and to the careful choice of professional products.

A single TMM series relay offers **ten different timer functions, freely programmable** by the user; these include, by way of example, time delay on pick-up or on drop-out, flasher, one-shot, etc.

The switching time can be selected within a wide range extending from 0.1 seconds to 99 hours, with **extreme accuracy** guaranteed across the full scale of adjustment. This is made possible by providing the relay with **ten intermediate scales**.

The timer function, the scale and the switching time are adjustable by means of four rotary switches, each having ten positions, located on the front of the relay.

The electronic circuit is immune to high electromagnetic interference, typical of high voltage electricity distribution stations. The construction of the relays and careful choice of the materials are such that they ensure long life and considerable ruggedness even in harsh operating environments and in the presence of strong temperature fluctuations.

Excellent electrical and mechanical performance levels allow the product to be used in the most demanding of sectors such as, for example, rail transport, control and signaling functions in electricity generating stations, electrical transformer stations, or in industries with continuous production processes (chemical and petroleum industries, rolling mills, cement factories, etc.). Above all, the excellent ability to withstand shock and vibration allow their use on rolling stock.

Models	Nominal current	Number of contacts		Rolling stock application
		Time-delayed	Instantaneous	
TMM2	10 A	2	2	•
TMM4	10 A	4	-	•

**FOR CONFIGURATION OF PRODUCT CODE, SEE "ORDERING SCHEME" TABLE**

Coil specifications	
Nominal voltages $U_n$ <sup>(1)</sup>	<b>DC:</b> 12-24-36-48-72-110-125-132-144-220 <b>AC:</b> 12-24-48-110-127-220-230
Maximum consumption at $U_n$ (DC/AC)	TMM2: 5.5 W / 7.5 VA      TMM4: 4.5 W / 6.5 VA
Operating range <sup>(1)</sup>	80 - 115 % $U_n$
Rolling stock version <sup>(2) (3)</sup>	DC: 70 - 125 % $U_n$
Type of duty	Continuous
Drop-out voltage <sup>(4)</sup>	> 15 % $U_n$

<sup>(1)</sup> Other values on request.

<sup>(2)</sup> See "Ordering scheme" table for order code.

<sup>(3)</sup> For operating ranges different to that specified by EN 60077, refer to table "Special operating ranges" on page 65.

<sup>(4)</sup> Limit value for supply voltage, expressed as % of the nominal value, beneath which the relay is certainly de-energized.

Contact specifications	TMM2	TMM4
Number and type	2 timed + 2 instantaneous C0, form C	4 timed, C0, form C
Current	10 A	
Nominal <sup>(1)</sup>	10 A	
Maximum peak (1 s) <sup>(2)</sup>	20 A (1 min) / 40 A (500 ms)	
Maximum pulse (10 ms) <sup>(2)</sup>	150 A	
Example of electrical life expectancy <sup>(3)</sup>	0.7 A – 132 V <sub>DC</sub> – L/R 40 ms: 10 <sup>5</sup> operations	
1,800 operations / hour	1 A – 110 V <sub>DC</sub> – L/R 0 ms: 10 <sup>5</sup> operations	
Making capacity	30 A (for 200 ms) – 110 V <sub>DC</sub> – L/R 0 ms: 2,000 operations	
Minimum load	500 mW (20 V, 20 mA)	
Standard contacts	100 mW (10 V, 5 mA)	
Gold-plated contact <b>P4GEO</b> <sup>(4)</sup>	50 mW (5 V, 5 mA)	
Gold-plated contact <b>P8</b> <sup>(4)</sup>	250 V <sub>DC</sub> / 350 V <sub>AC</sub>	
Maximum breaking voltage	AgCu	
Contact material	DC <sup>(7)</sup> – AC	
Operating time at $U_n$ (ms) <sup>(5) (6)</sup>	≤ 20 - ≤ 20	
Pick-up (NO contact closing)	≤ 15 - ≤ 20	
Drop-out (NC contact closing)		

<sup>(1)</sup> On all contacts simultaneously, reduction of 30 %.

<sup>(2)</sup> The maximum peak and pulse currents are those currents that can be handled, for a specified time, by the contact. They do not refer to steady or interrupted currents.

<sup>(3)</sup> For other values, see electrical life expectancy curves.

<sup>(4)</sup> Specifications of contacts on new relay

a. Plating material: **P4GEO: gold-nickel alloy (>6 μ)**      **P8: gold-cobalt alloy (>5 μ), knurled contact**

b. When the gold-plated contact is subject to heavy loads, it will be degraded on the surface. In such case, the specifications of the standard contact should be taken into consideration. This does not impair relay operation.

<sup>(5)</sup> Times for the instantaneous component of the relay (TMM2 model).

<sup>(6)</sup> Unless specified otherwise, the operating time signifies until stabilization of the contact (including bounces). They should be added to the preset delay time.

<sup>(7)</sup> Addition of a flyback diode connected in parallel with the coil (DC version only) causes an increase in operating time when the relay drops out.

Insulation	
Insulation resistance (at 500 V <sub>DC</sub> ) between electrically independent circuits and between these circuits and ground between open contact parts	> 1,000 MΩ > 1,000 MΩ
Withstand voltage at industrial frequency between electrically independent circuits and between these circuits and ground between open contact parts between adjacent contacts	2 kV (1 min) - 2.2 kV (1 s) 1 kV (1 min) - 1.1 kV (1 s) 2.5 kV (1 min) - 3 kV (1 s)
Impulse withstand voltage (1.2/50 μs - 0.5 J) between electrically independent circuits and between these circuits and ground between open contact parts	5 kV 3 kV

Mechanical specifications	
Mechanical life expectancy	10 x 10 <sup>6</sup> operations
Maximum switching rate	3,600 operations / hour
Degree of protection (with relay mounted)	IP40
Dimensions (mm) <sup>(1)</sup>	40 x 50 x 97
Weight (g)	~ 220

<sup>(1)</sup> Excluding output terminals

Environmental specifications	
Operating temperature	Standard (-13 to 131) °F (-25 to 55) °C Version for railways, rolling stock (-13 to 158) °F (-25 to 70) °C
Storage and shipping temperature	(-40 to 158) °F (-40 to 70) °C
Relative humidity	Standard: 75 % RH, Tropicalized: 95 % RH
Resistance to vibrations	5 g - 10 to 55 Hz - 1 min
Resistance to shock	20 g - 11 ms
Fire behavior	V0

Standards and reference values	
EN 61810-1, EN 61810-2, EN 61810-7	Electromechanical elementary relays
EN 61812-1	Timer relays
EN 60695-2-10	Fire behavior
EN 61000	Electromagnetic compatibility
EN 60529	Degree of protection provided by enclosures

Unless otherwise specified, the products are designed and manufactured according to the requirements of the above-mentioned European and International standards. In accordance with EN 61810-1, all items of technical data are referred to ambient temperature 23 °C, atmospheric pressure 96 kPa and 50 % humidity. Tolerance for coil resistance, nominal electrical input and nominal power is ± 7 %.

Railways, rolling stock - Standards	
EN 60077	Electric equipment for rolling stock — general service conditions and general rules
EN 50155	Electronic equipment used on rolling stock
EN 61373	Shock and vibration tests, CAT 1, Class B
EN 45545-2	Fire behavior, CAT E10, Requirement R26, V0
ASTM E162, E662	Fire behavior



### Railways, rolling stock - Special operating ranges <sup>(1)</sup>

Nominal voltage	Minimum pick-up voltage	Maximum operating voltage	Order symbol <sup>(1)</sup>
24 V <sub>DC</sub>	16.8	32	Z01
72 V <sub>DC</sub>	55	104	Z01
110 V <sub>DC</sub>	77	144	Z01

<sup>(1)</sup> To request the special range, indicate the “Z0x” symbol in the “Keying position” field in the “Ordering scheme” table. The special range may be subject to operating specifications different from standard specifications. Please contact us for further information.



### Configuration options

P2	Tropicalization of coil with epoxy resin for exposure to 95 % RH (@ T 50 °C). This treatment also protects the coil against corrosion which could occur by combination of the humidity with certain chemical agents, such as those found in acidic or saline atmospheres.
P4GEO	Gold plating of contacts with gold-nickel alloy, thickness ≥ 6 μ. This treatment ensures long-term capacity of the contact to conduct lower currents in harsh ambient conditions such as acid atmospheres (typical of geothermal power stations) or saline atmospheres.
P5GEO	<b>P4GEO</b> gold-plating of contacts + <b>P2</b> coil tropicalization.
P6GEO	<b>P4GEO</b> type gold-plating, but applied to contacts, contact terminals and output terminals + <b>P2</b> coil tropicalization.
P7	AgCdO (silver cadmium oxide) contacts.
P8	Gold plating of contacts with gold-cobalt alloy, thickness ≥ 5 μ, knurled fixed contact. This finish allows further improvement of the performance provided by gold-plated contact, compared to P4GEO treatment.
FLYBACK DIODE	Polarized component connected in parallel with the coil (type 1N4007 or BYW56 for rolling stock version) designed to suppress overvoltages generated by the coil when de-energized.
TRANSIL	Non-polarized component connected in parallel with the coil. Behavior is similar to that of a varistor, with faster operating times.



### Ordering scheme

Product code	Application <sup>(1)</sup>	Configuration A	Configuration B	Label	Type of power supply	Nominal voltage (V) <sup>(2)</sup>	Keying position <sup>(3)</sup>
TMM2 TMM4	<b>E:</b> Energy Railway Fixed Equipment <b>R:</b> Railway Rolling Stock	1: Standard 2: Diode // 3: Varistor 7: Transil	0: Standard 2: P2 4: P4 GEO 5: P5 GEO 6: P6 GEO 7: P7 8: P8	F	C: V <sub>DC</sub> A: V <sub>AC</sub> 50 Hz	012 - 024 - 036 048 - 072 - 100 110 - 125 - 127 132 - 144 - 220 230	XXX

Example

<b>TMM2</b>	<b>E</b>	<b>1</b>	<b>8</b>	<b>F</b>	<b>C</b>	<b>024</b>	
TMM2E18F-C024 - TMM2 relay, ENERGY series, nominal voltage 24 V <sub>DC</sub> , with P8 finish (gold-plated contacts)							
<b>TMM4</b>	<b>R</b>	<b>1</b>	<b>0</b>	<b>F</b>	<b>C</b>	<b>110</b>	
TMM4R10F-C110 - TMM4 relay, ROLLING STOCK series, nominal voltage 110 V <sub>DC</sub>							

<sup>(1)</sup> **E = ENERGY:** all applications, except for railways rolling stock. Suitable on energy production, transport and distribution plants, railways fixed equipment, petrochemical and heavy industry.

**R = RAILWAYS, ROLLING STOCK:** Application on board rolling stock (rail-tram-trolley vehicles). Electrical specifications according to EN 60077.

Other product series available:

**RAILWAYS, FIXED EQUIPMENT:** Approved and conforming relays and products to RFI (FS Group) specification no. RFI DPRIM STF IFS TE 143 A. For the list of RFI approved and conforming products, consult dedicated catalog “RAILWAY SERIES – RFI APPROVED”.

**STATIONS:** ENEL approved material meeting LV15/LV16 specifications. For the list of ENEL approved and conforming products, consult the dedicated catalog “STATIONS SERIES – LV15-LV16-LV20”.

<sup>(2)</sup> Other values on request.

<sup>(3)</sup> Optional value. The positive mechanical keying is applied according to the manufacturer’s model.

<sup>(4)</sup> Rolling Stock version, V<sub>DC</sub> only available.

INSTANTANEOUS MONOSTABLE  
INSTANTANEOUS MONOSTABLE WITH FORCIBLY GUIDED CONTACTS  
TIME DELAY (ON PICK-UP OR DROP-OUT)  
EXPLANATION OF SOCKET NUMBERING  
FRONT CONNECTION  
BACK CONNECTION  
PCB MOUNT  
RETAINING CLIPS  
KEYING PINS

## Dimensions and indicators

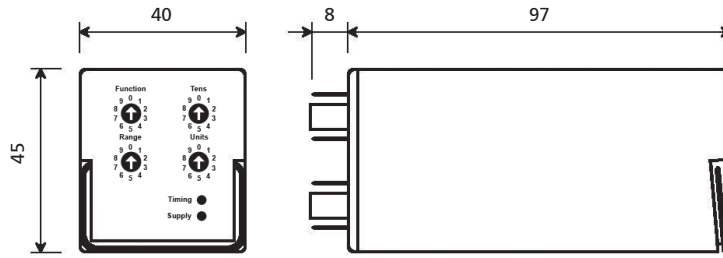

Timing = Green LED: time delay activated  
Supply = Red LED: auxiliary power on

## Wiring diagram

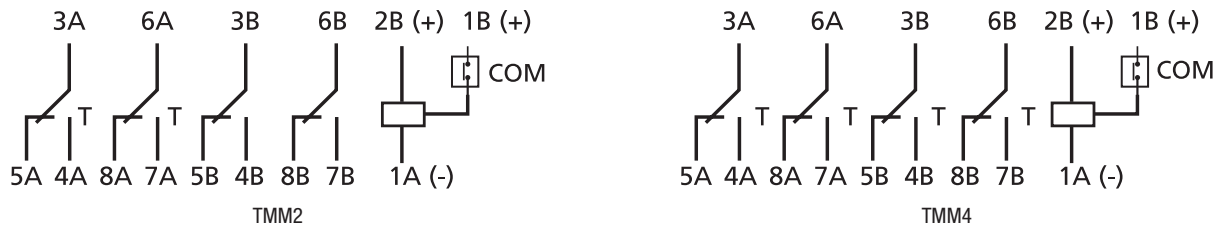

- T= time delay contacts
- Terminals 2B and 1A are allocated to the auxiliary power supply.
- Terminal 1B is allocated to CONTROL. The negative of the control circuit is common with that of the auxiliary power supply.
- Certain functions require an auxiliary power supply to guarantee operation of the time delay (terminal 2B).

## Time delay – Switching time setting

Controls setting function, range and time	4 rotary switches with 10 positions (0 - 9)
Time setting range	100 ms...99 h
Intermediate scales	10, from 9.9 seconds to 99 hours
Resolution of switching time setting	1 % of intermediate scale
Accuracy, time delay (0.8...1.1 U <sub>n</sub> , t=20 °C)	<b>DC:</b> ± 1 % of selected time or ± 10 ms <sup>(1)</sup> <b>AC:</b> ± 1 % of selected time; 0.1 s - 10 s: ± 2 % ± 20 ms
Accuracy, repeatability	<b>DC:</b> ± 0.5 % <b>AC:</b> ± 0.5 % + 20 ms
Reset	< 200 ms during time delay interval < 400 ms
“COM” control signal	> 10 mS

<sup>(1)</sup> Whichever of the two values is higher.

The function and switching time are adjustable by means of four rotary-switch selectors located on the front of the relay, each having ten positions, with which the user can select time delay settings between 100 ms and 99 hours.

The position of the arrow point on each rotary switch indicates the number selected. Adjustments are made by discrete steps, which means that no intermediate settings are possible.

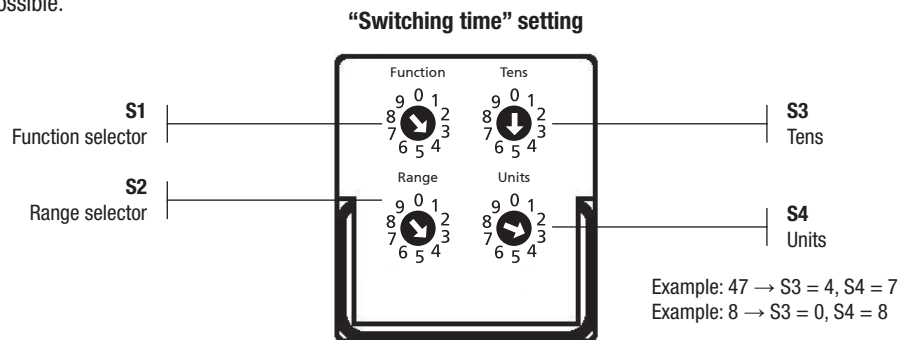

### Adjustment of switching time (except for function F6)

To adjust the switching time, the first step is to adjust the intermediate scale T(s), by selecting one of the 10 available scales using the S2 rotary switch. The values available are given in Table 1.

Scale	Minimum value	Maximum value	Step
0	0.1 s	9.9 s	100 ms
1	1 s	99 s	1 s
2	3 s	297 s	3 s
3	5 s	495 s	5 s
4	10 s	990 s	10 s
5	1 min	99 min	1 min
6	3 min	297 min	3 min
7	5 min	495 min	5 min
8	10 min	990 min	10 min
9	1 h	99 h	1 h

Table 1 – Available scales

Next, the switching time is adjusted by means of rotary-switch selectors S3 and S4. The combination of these two 10-position controls, located on the right, allows the selection of a number between 1 and 99. The number selected with the “Tens” arrow combined with the number selected with the “Units” arrow represents the multiplier of the step selected via the “Range” control. The resulting value gives the time used by the relay in operation.

Range



**Example of setting “4”.**  
Minimum value 10 s.  
Maximum value 990 s.  
The step setting is 10 s.

Tens



Units



**Example of setting “53”.**  
The scale selected previously is number 4, which has an adjustment step of 10 s.  
The time used by the relay in operation will be:  
53 x 10 s = 530 seconds.



Setting's changes have to be operate with relays switched off.  
Setting's changes with energized relay have no effect.

### Adjustment of switching time for function F5 – Asymmetric flash

Function F5 pilots an asymmetric flash. The “ON” time and the “OFF” time are adjustable independently

“ON” time (t) → selector S4

“OFF” time (T) → selector S4

**In this instance, selector S3 and selector S4 are both calibrated in UNITS. Position “0” assumes the value of 10 integers.**

Once the scale has been set by means of selector S2, selectors S3 and S4 are used to set the number that will provide the multiplier for the step of the selected scale.

Example: S2 = 1 → unit of time: seconds

S4 = 3 → t = 3 seconds

S3 = 0 → T = 10 seconds

INSTANTANEOUS MONOSTABLE

INSTANTANEOUS MONOSTABLE WITH FORCIBLY GUIDED CONTACTS

TIME DELAY (ON PICK-UP OR DROP-OUT)

EXPLANATION OF SOCKET NUMBERING

FRONT CONNECTION

BACK CONNECTION

PCB MOUNT

RETAINING CLIPS

KEYING PINS

SELECTING THE FUNCTION

The function is selected by positioning the arrow of selector S1 so that the point is aligned with the number of the required function.

Function	Description
F0	Time delay on pick-up.
F1	Time delay on drop-out. Instantaneous contacts follow the status of the auxiliary power supply.
F2	Time delay on drop-out, instantaneous contacts on "CONTROL". Instantaneous contacts follow the status of the control signal.
F3	One-shot function.
F4	Flasher, symmetrical. The "ON" time and the "OFF" time are the same.
F5	Flasher, asymmetrical. The "ON" time and the "OFF" time are different, and adjustable independently.
F6	One-shot function on "CONTROL". The timing cycle starts on activation of the control signal.
F7	One-shot function with fixed pulse (3 s), delayed at pick-up. Pulse delay adjustable.
F8	One-shot function, on "CONTROL", with fixed pulse (3 s), delayed at pick-up. The timing cycle starts on activation of the control signal. Pulse delay adjustable.
F9	Step function.

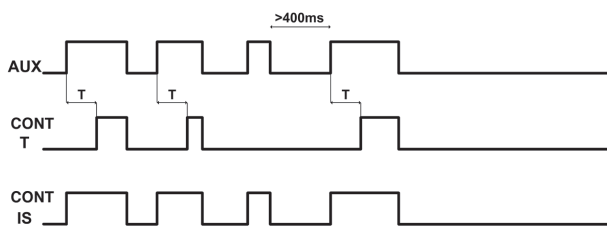

F0 – Time delay on pick-up.

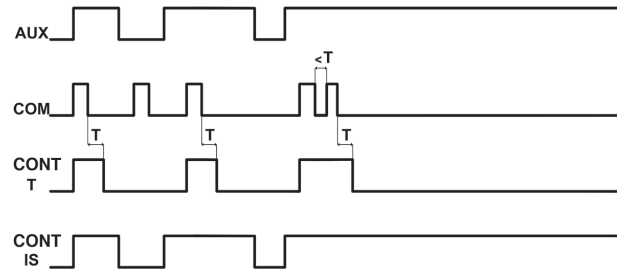

F1 – Time delay on drop-out, instantaneous contacts follow the status of the auxiliary power supply.  
The instantaneous contacts follow the status of the auxiliary power supply (2B terminal).

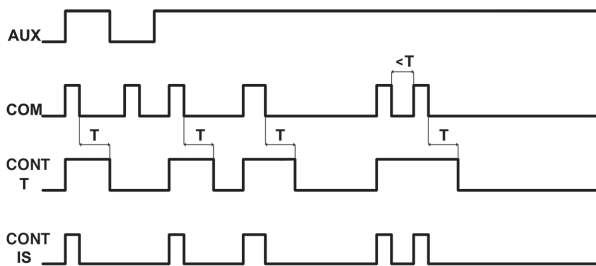

F2– Time delay on drop-out.  
The instantaneous contacts follow the status of the control signal ("COM", 1B terminal).

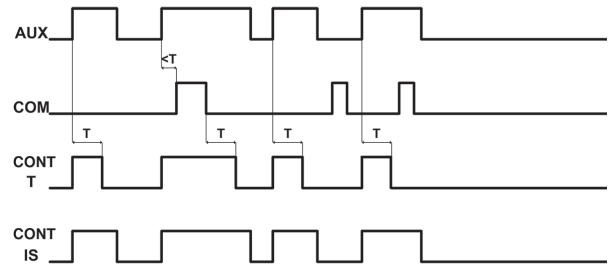

F3 – One-shot function.  
The control signal ("COM", 1B terminal) resets the time "t", on drop-out.

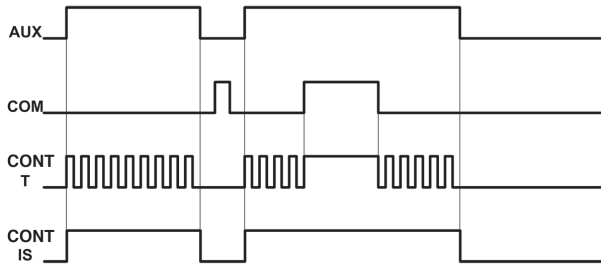

F4 – Flasher, symmetrical.  
The control signal (“COM”, 1B terminal) stops the flash.

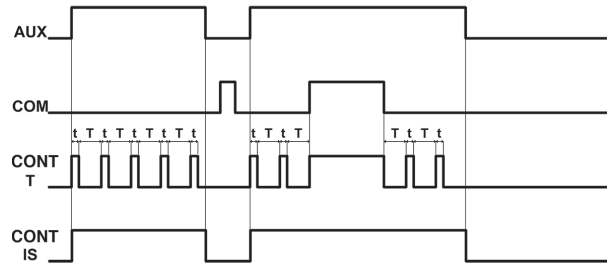

F5 – Flasher, asymmetrical.  
The control signal (“COM”, 1B terminal) stops the flash t and T are adjustable using the same unit of time.  
Example: S2 = 1Φ unit of time: seconds  
S4 = 3Φ t = 3 seconds  
S3 = 0Φ T = 10 seconds

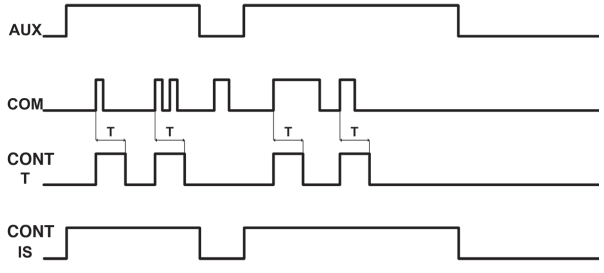

F6– One-shot function on “CONTROL” (COM).

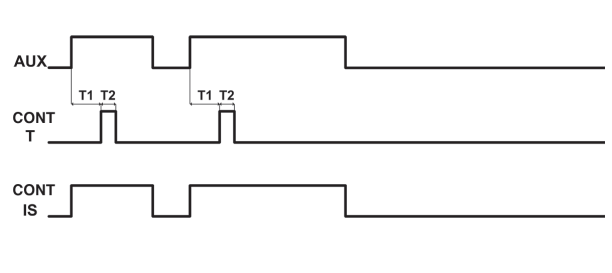

F7 – One-shot function with fixed pulse (3s), delayed at pick-up.  
T1: adjustable by way of selector S3 / S4  
T2: fixed, 3 seconds

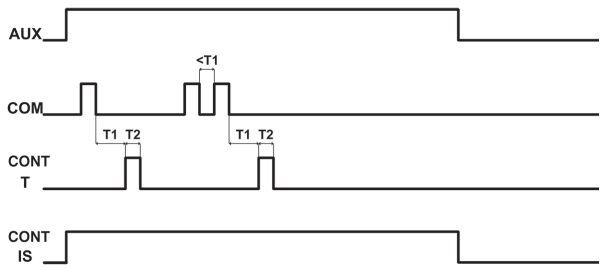

F8 – One-shot function, on “CONTROL”, with fixed pulse (3s), delayed at pick-up.  
T1: adjustable by way of selector S3 / S4  
T2: fixed, 3 seconds  
Control signal (“COM”, 1B terminal) starts time delay T1  
Control signal (“COM”, 1B terminal) restarts the time, if this appears during the time delay.

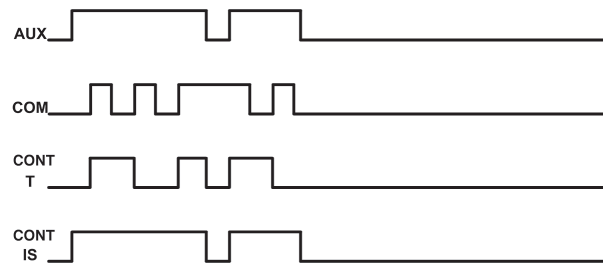

F9 - Step function  
The S3 and S4 switches have no effect on the relay operation.

Applicable note for all operating diagrams:

- AUX: 2B - 1A terminals
- COM: 1B terminal
- CONT T: timed contacts
- CONT I: instantaneous contacts

See “Wiring diagram” on page 66 to identify the instantaneous and timed contacts terminals.

## Electrical life expectancy <sup>(1)</sup>

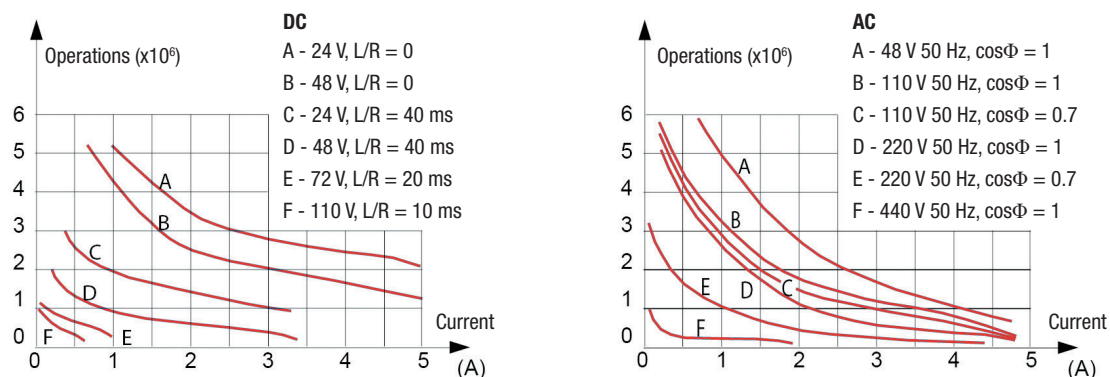

### Examples of electrical life expectancy:

12 V<sub>DC</sub> - 10 A - Resistive: 10<sup>5</sup> operations

48 V<sub>DC</sub> - 5 A - L/R 10 ms: 5 × 10<sup>5</sup> operations

80 V<sub>DC</sub> - 5 A - Resistive: 5 × 10<sup>5</sup> operations

110 V<sub>DC</sub> - 0.5 A - L/R 10 ms: 5 × 10<sup>5</sup> operations

110 V<sub>DC</sub> - 1 A - L/R 0 ms: 10<sup>5</sup> operations

132 V<sub>DC</sub> - 0.7 A - 132 V<sub>DC</sub> - L/R 40 ms: 10<sup>5</sup> operations

220 V<sub>DC</sub> - 0.2 A - L/R 10 ms: 10<sup>5</sup> operations

110 V<sub>AC</sub> - 5 A -  $\cos\Phi$  0.7: 5 × 10<sup>5</sup> operations

220 V<sub>AC</sub> - 3 A -  $\cos\Phi$  0.7: 5 × 10<sup>5</sup> operations

440 V<sub>AC</sub> - 0.2 A - Resistive: 5 × 10<sup>5</sup> operations

<sup>(1)</sup> Switching frequency 1,200 operations / hour, 50 % cycle.

## Sockets and retaining clips

	Number of terminals (standard dimensions 5 x 0.8 mm)	16	Retaining clip
For wall or rail mounting			
	Spring clamp, wall or DIN H35 rail mounting	PAIR160	RT48
	Screw, wall or DIN H35 rail mounting	48BIP20-I DIN	RT48
	Screw, wall mounting	48BL	RT48
For flush mounting			
	Spring clamp	PRIR160	RT48
	Double faston (4.8 × 0.8 mm)	ADF2	RL48
	Screw	43IL <sup>(1)</sup>	RT43
For mounting on PCB			
		65	RT43

<sup>(1)</sup> Insert the clip before fastening the socket on the panel. For more details, see specifications of mounting accessories.

## Mounting tips

- The preferred mounting position is on the wall, with the relay positioned horizontally in the reading direction on the nameplate.
- For correct use of the relays, they should be spaced apart by at least 5 mm in the horizontal direction and 20 mm in the vertical direction. This is to allow correct upward dissipation of the heat generated by the coil. Set these distances according to the socket used. Distances can be reduced depending on the environmental application conditions and on the relay duty cycle.
- For safe and secure operation, it is advisable to use retaining clips.
- No special maintenance is required.
- Condensation can form inside the relay when powered up and the outside ambient temperature is cold; this is quite normal and does not affect the operation of the relay. The plastic materials of the relay do not possess hygroscopic properties.





RELAYS

## MULTISCALE MONOSTABLE TIMER RELAYS WITH 4 CONTACTS

## TM SERIES

## USER SECTORS



Power generation



Nuclear



Power transmission



Rolling stock



Fixed railway installations



Shipbuilding



Petroleum industry



Heavy industry

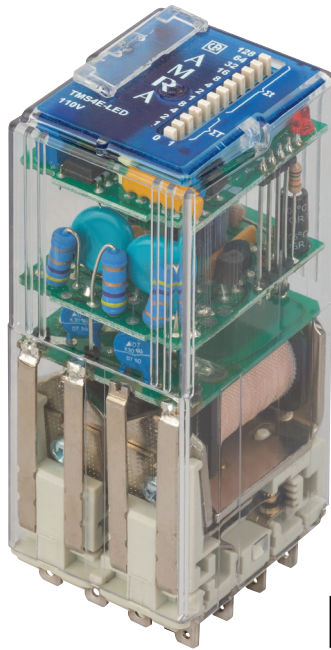

TM

ERC

## PRODUCT ADVANTAGES

- Plug-in relay with time delay on pick-up or on drop-out
- 4 time delay contacts or 2 time delay contacts + 2 instantaneous contacts
- Wide time setting range from 0.1 s to 9 hours, great accuracy over the entire adjustment range
- High electromagnetic interference immunity
- Solid and rugged construction for heavy or intensive duty
- Long life expectancy
- Independent and self-cleaning contacts
- Magnetic arc blow-out standard
- Separate arc breaking chambers
- Excellent shock and vibration resistance
- Wide variety of configurations and customizations
- Option for use in geothermal sites available
- Wide range of sockets
- Retaining clip for secure locking of relay on socket
- Transparent cover, pull-out handle
- Positive mechanical keying for relay and socket

## DESCRIPTION

The **TM series** is a range of relays with electronic time delay on pick-up or drop-out, consisting of eight models with 4 change-over contacts, from 5 to 10 A (nominal). They are obtained by assembling the electromechanical units of the POK or BIPOK series with a digital electronic circuit. The electromechanical part features the **reliability and ruggedness** of relays belonging to the POK series, while the electronics offers high reliability thanks to the use of an electronic circuit requiring few components and to the careful choice of professional products.

With the same product it is possible to obtain switching **times ranging from 0.1 second to over 9 hours**, with the greatest of accuracy over the entire setting range. This is thanks to the fact that the relay has 16 intermediate scales, freely selectable by the user.

Switching time is adjustable by means of two DIP switches, 4- and 8-bit respectively, located on the front of the relay. The 4-bit DIP switch serves for selecting the most suitable intermediate scale, while the 8-bit DIP switch is used for precision selection of the switching time.

On request, the models are available with fixed switching time to avoid modifications to the time setting.

The electronic circuit is immune to high electromagnetic interference, typical of high voltage electricity distribution stations.

The construction of the relays and careful choice of the materials are such that they ensure **long life** and considerable **ruggedness** even in harsh operating environments and in the presence of strong temperature fluctuations.

Excellent electrical and mechanical performance levels allow the product to be used in the most demanding of sectors such as, for example, control and signaling functions in electricity generating stations, electrical transformer stations, rail transport or in industries with continuous production processes (chemical industry, petroleum industry, rolling mills, cement factories, etc.). A specific treatment (P5GEO or P6GEO) combining coil tropicalization with gold-plated contacts allows the use of these items in geothermal electric power stations, as relays for signaling functions, for controlling intermediate devices and for all non-power circuits.

Above all, the excellent ability to withstand shock and vibration allow their use on rolling stock.

Models	Function		Nominal current		Number of contacts		Rolling stock application
	Pick-up	Drop-out	5 A	10 A	Time-delayed	Instantaneous	
TM2E	•		•		2	2	•
TM4E	•		•		4	-	•
TMS2E	•			•	2	2	•
TMS4E	•			•	4	-	•
TM2R		•	•		2	2	•
TM4R		•	•		4	-	•
TMS2R		•		•	2	2	•
TMS4R		•		•	4	-	•

**FOR CONFIGURATION OF PRODUCT CODE, SEE "ORDERING SCHEME" TABLE**

Coil specifications	
Nominal voltages $U_n$ <sup>(1)</sup>	<b>DC:</b> 12-24-36-48-72-96-110-125-132-144-220 <b>AC:</b> 12-24-48-110-127-220-230
Maximum consumption at $U_n$ (DC/AC)	4 W / 5 VA
Operating range <sup>(1)</sup>	80 - 115 % $U_n$
Rolling stock version <sup>(2) (3)</sup>	DC: 70 - 125 % $U_n$
Type of duty	Continuous
Drop-out voltage <sup>(4)</sup>	DC: > 5 % $U_n$ AC: > 15 % $U_n$

<sup>(1)</sup> Other values on request.

<sup>(2)</sup> See "Ordering scheme" table for order code.

<sup>(3)</sup> For operating ranges different to that specified by EN 60077, refer to table "Special operating ranges" on page 75.

<sup>(4)</sup> Limit value for supply voltage, expressed as % of the nominal value, beneath which the relay is certainly de-energized.

Contact specifications		TM2E - TM2R	TM4E - TM4R	TMS2E - TMS2R	TMS4E - TMS4R
Number and type		2 + 2 instantaneous CO, form C	4 CO, form C	2 + 2 instantaneous CO, form C	4 CO, form C
Current	Nominal <sup>(1)</sup>	5 A		10 A	
	Maximum peak (1 s) <sup>(2)</sup>	10 A		20 A	
	Maximum pulse (10 ms) <sup>(2)</sup>	100 A		150 A	
Example of electrical life expectancy <sup>(3)</sup> 1,800 operations / hour		0.2 A – 110 V <sub>DC</sub> – L/R = 40 ms: 10 <sup>5</sup> operations 0.7 A – 110 V <sub>DC</sub> – L/R = 0 ms: 10 <sup>5</sup> operations		0.5 A – 110 V <sub>DC</sub> – L/R = 40 ms: 10 <sup>5</sup> operations 1 A – 110 V <sub>DC</sub> – L/R = 0 ms: 10 <sup>5</sup> operations	
Minimum load	Standard contacts	500 mW (20 V, 20 mA)			
	Gold-plated contact <b>P4GEO</b> <sup>(4)</sup>	100 mW (10 V, 5 mA)			
	Gold-plated contact <b>P8</b> <sup>(4)</sup>	50 mW (5 V, 5 mA)			
Maximum breaking voltage		250 V <sub>DC</sub> / 350 V <sub>DC</sub>			
Contact material		AgCu		Ag / AgCu	
Operating time at $U_n$ (ms) <sup>(5) (6)</sup>		DC <sup>(7)</sup> – AC			
Pick-up (NO contact closing)		≤ 20 - ≤ 20			
Drop-out (NC contact closing)		≤ 15 - ≤ 20			

<sup>(1)</sup> On all contacts simultaneously, reduction of 30 %.

<sup>(2)</sup> The maximum peak and pulse currents are those currents that can be handled, for a specified time, by the contact. They do not refer to steady or interrupted currents.

<sup>(3)</sup> For other values, see electrical life expectancy curves.

<sup>(4)</sup> Specifications of contacts on new relay

a. Plating material: **P4GEO: gold-nickel alloy (>6 μ)**      **P8: gold-cobalt alloy (>5 μ), knurled contact**

b. When the gold-plated contact is subject to heavy loads, it will be degraded on the surface. In such case, the specifications of the standard contact should be taken into consideration. This does not impair relay operation.

<sup>(5)</sup> Times for the instantaneous component of the relay.

<sup>(6)</sup> Unless specified otherwise, the operating time signifies until stabilization of the contact (including bounces). They should be added to the preset delay time.

<sup>(7)</sup> Addition of a flyback diode connected in parallel with the coil (DC version only) causes an increase in operating time when the relay drops out.

⚡ Insulation	
Insulation resistance (at 500 V <sub>DC</sub> ) between electrically independent circuits and between these circuits and ground between open contact parts	> 1,000 MΩ > 1,000 MΩ
Withstand voltage at industrial frequency between electrically independent circuits and between these circuits and ground between open contact parts between adjacent contacts	2 kV (1 min) - 2.2 kV (1 s) 1 kV (1 min) - 1.1 kV (1 s) 2.5 kV (1 min) - 3 kV (1 s)
Impulse withstand voltage (1.2/50 μs - 0.5 J) between electrically independent circuits and between these circuits and ground between open contact parts	5 kV 3 kV

⚙ Mechanical specifications	
Mechanical life expectancy	DC: 20 x 10 <sup>6</sup> AC: 10 x 10 <sup>6</sup> operations
Maximum switching rate	Mechanical 3,600 operations / hour
Degree of protection (with relay mounted)	IP40
Dimensions (mm) <sup>(1)</sup> Weight (g)	40 x 50 x 97 ~ 220

<sup>(1)</sup> Excluding output terminals

💡 Environmental specifications	
Operating temperature	Standard (-13 to 131) °F (-25 to 55) °C Version for railways, rolling stock (-13 to 158) °F (-25 to 70) °C
Storage and shipping temperature	(-40 to 185) °F (-40 to 85) °C
Relative humidity	Standard: 75 % RH, Tropicalized: 95 % RH
Resistance to vibrations	5 g - 10 to 55 Hz - 1 min
Resistance to shock	20 g - 11 ms
Fire behavior	V0

📄 Standards and reference values	
EN 61810-1, EN 61810-2, EN 61810-7	Electromechanical elementary relays
EN 61812-1	Timer relays
EN 60695-2-10	Fire behavior
EN 61000	Electromagnetic compatibility
EN 60529	Degree of protection provided by enclosures

Unless otherwise specified, the products are designed and manufactured according to the requirements of the above-mentioned European and International standards. In accordance with EN 61810-1, all items of technical data are referred to ambient temperature 23 °C, atmospheric pressure 96 kPa and 50 % humidity. Tolerance for coil resistance, nominal electrical input and nominal power is ± 7 %.

🚂 Railways, rolling stock - Standards	
EN 60077	Electric equipment for rolling stock — general service conditions and general rules
EN 50155	Electronic equipment used on rolling stock
EN 61373	Shock and vibration tests, CAT 1, Class B
EN 45545-2	Fire behavior, CAT E10, Requirement R26, V0
ASTM E162, E662	Fire behavior
CU TR 001/2011	Safety of railway rolling stock - EAC certification



## Railways, rolling stock - Special operating ranges <sup>(1)</sup>

Nominal voltage	Minimum pick-up voltage	Maximum operating voltage	Order symbol <sup>(1)</sup>
24 V <sub>DC</sub>	18	33	Z01
24 V <sub>DC</sub>	16	32	Z02
24 V <sub>DC</sub>	16.8	32	Z03
72 V <sub>DC</sub>	55	104	Z01
110 V <sub>DC</sub>	77	144	Z01

<sup>(1)</sup> To request the special range, indicate the “Z0x” symbol in the “Keying position” field in the “Ordering scheme” table. The special range may be subject to operating specifications different from standard specifications. Please contact us for further information.



## Configuration options

P2	Tropicalization of coil with epoxy resin for exposure to 95 % RH (@ T 50 °C). This treatment also protects the coil against corrosion which could occur by combination of the humidity with certain chemical agents, such as those found in acidic or saline atmospheres.
P4GEO	Gold plating of contacts with gold-nickel alloy, thickness ≥ 6 μ. This treatment ensures long-term capacity of the contact to conduct lower currents in harsh ambient conditions such as acid atmospheres (typical of geothermal power stations) or saline atmospheres.
P5GEO	<b>P4GEO</b> gold-plating of contacts + <b>P2</b> coil tropicalization.
P6GEO	<b>P4GEO</b> type gold-plating, but applied to contacts, contact terminals and output terminals + <b>P2</b> coil tropicalization.
P7	AgCdO (silver cadmium oxide) contacts.
P8	Gold plating of contacts with gold-cobalt alloy, thickness ≥ 5 μ, knurled fixed contact. This finish allows further improvement of the performance provided by gold-plated contact, compared to P4GEO treatment.
LED	LED indicator showing presence of power supply, wired in parallel with the coil.
FLYBACK DIODE	Polarized component connected in parallel with the coil (type 1N4007 or BYW56 for rolling stock version) designed to suppress overvoltages generated by the coil when de-energized.
TRANSIL	Non-polarized component connected in parallel with the coil. Behavior is similar to that of a varistor, with faster operating times.
LOW TEMPERATURE	Minimum operating temperature -50 °C, only for rolling stock version (option “L”).



## Ordering scheme

Product code	Application <sup>(1)</sup>	Configuration A	Configuration B	Label	Type of power supply	Nominal voltage (V) <sup>(2)</sup>	Keying position <sup>(3)</sup>
TM2E TM4E TMS2E TMS4E TM2R TM4R TMS2R TMS4R	<b>E:</b> Energy Railway Fixed Equipment  <b>R:</b> Railway Rolling Stock	1: Standard 2: Diode // 3: Varistor 4: LED 5: Diode // + LED 6: Varistor + LED 7: Transil 8: Transil + LED	0: Standard 2: P2 4: P4 GEO 5: P5 GEO 6: P6 GEO 7: P7 8: P8	F	C: V <sub>DC</sub> A: V <sub>AC</sub> 50 Hz H: V <sub>AC</sub> 60 Hz	012 - 024 - 036 048 - 072 - 096 100 - 110 - 125 127 - 132 - 144 220 - 230	XXX  L= Low temperature

Example	<b>TMS2R</b>	<b>E</b>	<b>4</b>	<b>2</b>	<b>F</b>	<b>A</b>	<b>230</b>	
	TMS2RE42F-A230 - TMS2R relay, ENERGY series, nominal voltage 230 V <sub>AC</sub> , provided with LED, with P2 finish (tropicalized coil)							
	<b>TM4R</b>	<b>4</b>	<b>1</b>	<b>8</b>	<b>F</b>	<b>C</b>	<b>024</b>	<b>L</b>
	TM4RR18F-C024 - TM4R relay, ROLLING STOCK series, nominal voltage 24 V <sub>DC</sub> , with P8 finish (gold-plated contacts) and option “L” (low temp.)							

<sup>(1)</sup> **E = ENERGY:** all applications, except for railways rolling stock. Suitable on energy production, transport and distribution plants, railways fixed equipment, petrochemical and heavy industry.

**R = RAILWAYS, ROLLING STOCK:** Application on board rolling stock (rail-tram-trolley vehicles). Electrical specifications according to EN 60077.

Other product series available:

**RAILWAYS, FIXED EQUIPMENT:** Approved and conforming relays and products to RFI (FS Group) specification no. RFI DPRIM STF IFS TE 143 A. For the list of RFI approved and conforming products, consult dedicated catalog “RAILWAY SERIES – RFI APPROVED”.

**STATIONS:** ENEL approved material meeting LV15/LV16 specifications. For the list of ENEL approved and conforming products, consult the dedicated catalog “STATIONS SERIES – LV15-LV16-LV20”.

<sup>(2)</sup> Other values on request.

<sup>(3)</sup> Optional value. The positive mechanical keying is applied according to the manufacturer’s model.

## Wiring diagram

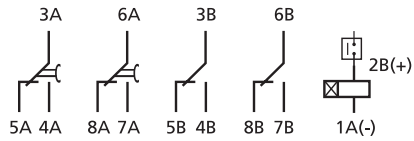

**TM2E - TMS2E**

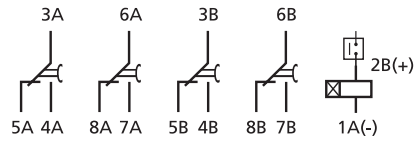

**TM4E - TMS4E**

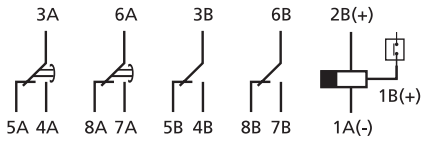

**TM2R - TMS2R**

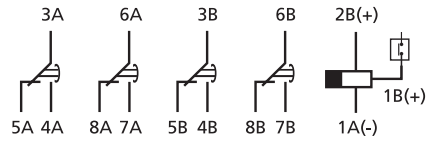

**TM4R - TMS4R**

Relays with time delay on drop-out require an auxiliary power supply to ensure correct timing (terminal 2B)

## Functional diagram

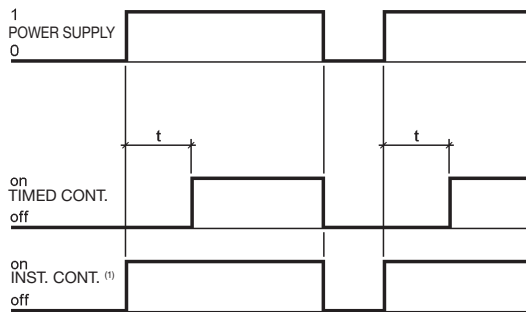

Time-delay on pick-up (version 2E, 4E)

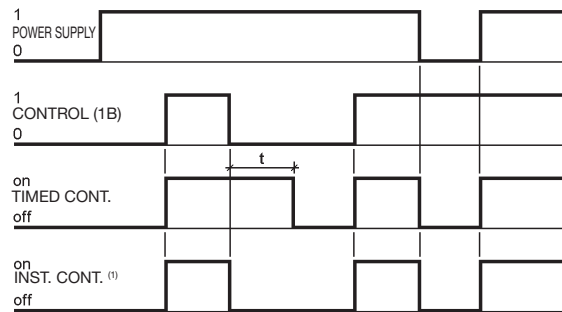

Time-delay on drop-out (version 2R, 4R)

<sup>(1)</sup> Instantaneous contacts are present only on versions "2E" and "2R"

## Time delay – Switching time setting

Time setting	By way of DIP switches
Time setting range	100 ms - 32,768 s
Intermediate scale	16, from 1 second to 32,768 seconds
Resolution of switching time setting	1/256 of the selected scale
Accuracy, time-delay <sup>(1)</sup>	± 1 % of the switching time, ± 0.5 % of the scale
Accuracy, repeatability	DC: ± 0.5 %    AC: ± 0.5 % + 20 ms
Reset	< 100 ms in time-delay phase < 400 ms
Insensitivity to voltage drops	< 100 ms

<sup>(1)</sup> Additional error for drop-out versions: 100 ms

The switching time is adjustable via the DIP switches (4- and 8-bit respectively) located on the front of the relay, through which it is possible to obtain time delays from 100 ms to 32,768 seconds (about 9 hours). To adjust the switching time, the first step is to adjust the intermediate scale T(s), by selecting one of the 16 available scales using the 4-bit DIP switch. The values available are given in table 1. The value of the T(s) scale should be the next highest numerically than the value of the required switching time. E.g. Switching time: 3,600 seconds → intermediate scale to set: 4,096 seconds The T(s) scale is set by identifying the switches that add up to the  $\Sigma T$  value indicated in table 1, and positioning them at "1".

Next, proceed to set the switching time by means of the 8-bit DIP switch.

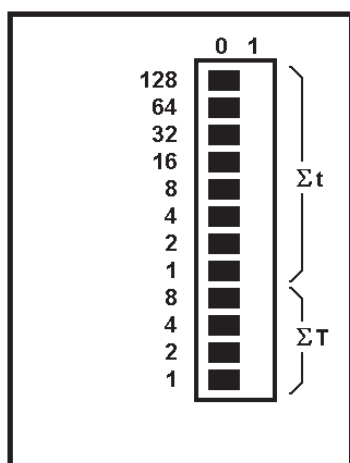

$\Sigma t$   
Switching time  
DIP switches  
(8 bit)

$\Sigma$   
Intermediate scale  
DIP switches  
(4 bit)

T(s)	$\Sigma T$	Switch reference			
		8	4	2	1
		Switch position			
1	0	0	0	0	0
2	1	0	0	0	1
4	2	0	0	1	0
8	3	0	0	1	1
16	4	0	1	0	0
32	5	0	1	0	1
64	6	0	1	1	0
128	7	0	1	1	1
256	8	1	0	0	0
512	9	1	0	0	1
1,024	10	1	0	1	0
2,048	11	1	0	1	1
4,096	12	1	1	0	0
8,192	13	1	1	0	1
16,384	14	1	1	1	0
32,768	15	1	1	1	1

Table 1

The switching time is set by identifying the 16-bit DIP switches that add up to the  $\Sigma T$  value, as calculated below, and positioning them at "1":

$$\Sigma t = \frac{t \times 256}{T} \quad \text{where } t(s): \text{ required switching time, and } T(s): \text{ full scale time set previously}$$

**Example:** Relay with time delay 22 s and full scale time 32 s.

For the full scale time of 32 s, select value 5 in the  $\Sigma T$  column (see table), then identify the switches corresponding to 4 and 1 (4+1=5) and position them at "1". For the delay time of 22 s, set an  $\Sigma T$  value of 176 (i.e.  $22 \times 256 / 32$ ), then identify the switches corresponding to 128, 32 and 16 (128+32+16=176) and position them at "1".

## Dimensions

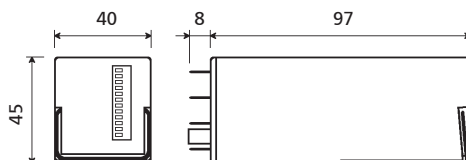

## Electrical life expectancy <sup>(1)</sup>

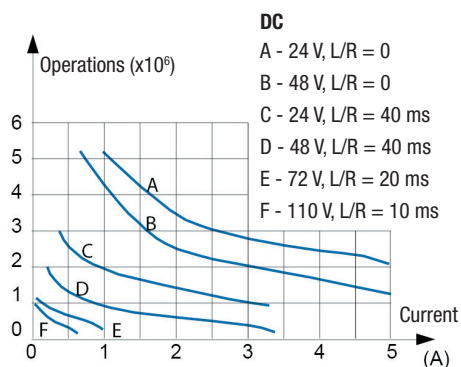

**Examples of electrical life expectancy:**  
 48 V<sub>DC</sub> - 5 A - L/R 10 ms:  $5 \times 10^5$  operations  
 80 V<sub>DC</sub> - 5 A - Resistive:  $5 \times 10^5$  operations  
 110 V<sub>DC</sub> - 0.5 A - L/R 10 ms:  $5 \times 10^5$  operations

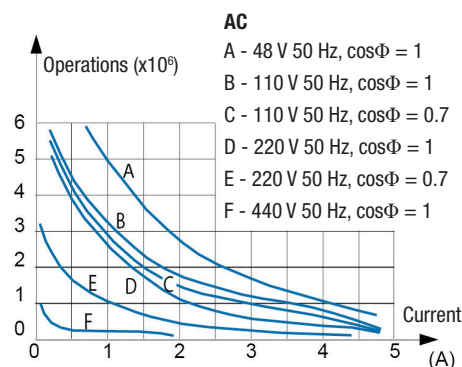

220 V<sub>DC</sub> - 0.2 A - L/R 10 ms:  $10^5$  operations  
 110 V<sub>AC</sub> - 5 A -  $\cos\Phi$  0.7:  $5 \times 10^5$  operations  
 220 V<sub>AC</sub> - 3 A -  $\cos\Phi$  0.7:  $5 \times 10^5$  operations  
 440 V<sub>AC</sub> - 0.2 A - Resistive:  $5 \times 10^5$  operations

<sup>(1)</sup> Switching frequency 1,200 operations / hour, 50 % cycle.

## Sockets and retaining clips

	Number of terminals	16	Retaining clip
<b>For wall or rail mounting</b>			
Spring clamp, wall or DIN H35 rail mounting		PAIR160	RT48
Screw, wall or DIN H35 rail mounting		48BIP20-I DIN	RT48
Screw, wall mounting		48BL	RT48
Double faston, wall mounting		48L	RT48
<b>For flush mounting</b>			
Double faston (4.8 × 0.8 mm)		ADF2	RT48
Screw		43IL <sup>(1)</sup>	RT43
<b>For mounting on PCB</b>			
		65	RT43

<sup>(1)</sup> Insert the clip before fastening the socket on the panel.

For more details, see specifications of mounting accessories.

## Mounting tips

- The preferred mounting position is on the wall, with the relay positioned horizontally in the reading direction on the nameplate.
- For correct use of the relays, they should be spaced apart by at least 5 mm in the horizontal direction and 20 mm in the vertical direction. This is to allow correct upward dissipation of the heat generated by the coil. Set these distances according to the socket used. Distances can be reduced depending on the environmental application conditions and on the relay duty cycle.
- For safe and secure operation, it is advisable to use retaining clips.
- No special maintenance is required.
- Condensation can form inside the relay when powered up and the outside ambient temperature is cold; this is quite normal and does not affect the operation of the relay. The plastic materials of the relay do not possess hygroscopic properties.





RELAYS

## TIMER RELAY WITH 4 CONTACTS

# TOK SERIES

### USER SECTORS



Power generation



Nuclear



Power transmission



Rolling stock



Fixed railway installations



Shipbuilding



Petroleum industry



Heavy industry

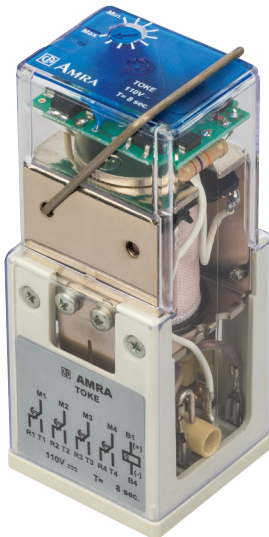

TOK

### PRODUCT ADVANTAGES

- TOK: Relay with time delay on pick-up or on drop-out
- Wide range of time settings available
- Solid and rugged construction for heavy or intensive duty
- Very long electrical life expectancy and exceptional endurance
- Independent and self-cleaning contacts with high breaking capacity
- Patent operating mechanism, designed to ensure high contact pressure
- Magnetic arc blow-out for higher breaking capacity
- Excellent shock and vibration resistance
- Wide range of sockets
- Retaining clip for secure locking of relay on socket
- Transparent cover, pull-out handle
- Positive mechanical keying for relay and socket

### DESCRIPTION

The relays in the **TOK series** are monostable types with time delay, using four CO contacts. Manufactured following the same basic electromechanical design of the OK Series, they embody all the features and benefits of this product. These models are suitable for use in the most demanding of sectors such as, for example, electricity generating stations, electrical transformer stations, industries using continuous production processes, and railways - fixed equipment and rolling stock alike. An ample clearance between open contact elements is instrumental in ensuring optimum performance when breaking high loads. The use of a **magnetic arc blow-out** helps to achieve a considerable increase in breaking capacity, even when handling **highly inductive loads**.

### TOK Series

The TOKe and TOKr relays provide time delays on **pick-up and drop-out respectively**, using four CO contacts. Intended originally for use in nuclear power plants, these relays are designed to guarantee particularly **high reliability and superior strength**. The time interval is adjusted by way of a potentiometer with a flat-head slotted screw, accessed from the top of the cover. A LED indicates energized status of the coil.

*For further details of electromechanical construction, see "OK series" on page 26.*

Models	Function		Number of contacts	Magnetic arc blow-out	Adjustable	Fixed time delay, capacitor controlled	Rolling stock application
	Pick-up	Drop-out			Time delay		
TOKe	•		4	•	•		•
TOKr		•	4	•	•		•



FOR CONFIGURATION OF PRODUCT CODE, SEE "ORDERING SCHEME" TABLE



### Coil specifications

Nominal voltages $U_n$ <sup>(1)</sup>	DC: 24-36-48-72-110-125-132-144-220	AC: 24-48-110-125-220-230
Maximum consumption at $U_n$	4 W / VA	
Operating range	Standard	80...115 % $U_n$
	Rolling stock version <sup>(1) (2)</sup>	DC: 70...125 % $U_n$
Type of duty	Continuous	
Drop-out voltage <sup>(3)</sup>	> 5 % $U_n$	

<sup>(1)</sup> Other values on request.

<sup>(2)</sup> See "Ordering scheme" table for order code.

<sup>(3)</sup> Limit value for supply voltage, expressed as % of the nominal value, beneath which the relay is certainly de-energized.



### Contact specifications

Contact specifications		TOKe - TOKr
Number and type		4 CO, form C
Current	Nominal <sup>(1)</sup>	10 A
	Maximum peak (1 s) <sup>(2)</sup>	20 A
	Maximum pulse (10 ms) <sup>(2)</sup>	150 A
Example of electrical life expectancy <sup>(3)</sup>	1,800 operations / hour	0.7 A – 132 V <sub>DC</sub> – L/R = 40 ms: 10 <sup>5</sup> operations
Minimum load	Standard contacts	500 mW (20 V, 20 mA)
	Gold-plated contacts <b>P4GEO</b> <sup>(4)</sup>	100 mW (10 V, 5 mA)
Maximum breaking voltage		350 V <sub>DC</sub> / 440 V <sub>AC</sub>
Contact material		AgCu
Operating time at $U_n$ (ms) <sup>(5)</sup>	Pick-up (NO contact closing)	≤ 38
	Drop-out (NC contact closing)	DC: ≤ 8 AC: ≤ 80

<sup>(1)</sup> Nominal current: on all contacts simultaneously.

<sup>(2)</sup> The maximum peak and pulse currents are those currents that can be handled, for a specified time, by the contact. They do not refer to steady or interrupted currents.

<sup>(3)</sup> For other values, see electrical life expectancy curves.

<sup>(4)</sup> Specifications of gold-plated contacts on new relay

a. Plating material: **P4GEO**: gold-nickel alloy (>6 μ).

b. When the gold-plated contact is subject to heavy loads, it will be degraded on the surface. In such case, the specifications of the standard contact should be taken into consideration. This does not impair relay operation.

<sup>(5)</sup> Unless specified otherwise, the operating time signifies until stabilization of the contact (including bounces). It should be added to the preset delay time.

<sup>(6)</sup> e(t) = DC < 15 % / AC < 20 % of selected time delay.

Insulation	
Insulation resistance (at 500 V <sub>DC</sub> ) between electrically independent circuits and between these circuits and ground between open contact parts	> 1,000 MΩ > 1,000 MΩ
Withstand voltage at industrial frequency between electrically independent circuits and between these circuits and ground between open contact parts between adjacent contacts	2 kV (1 min) - 2.2 kV (1 s) 2 kV (1 min) - 2.2 kV (1 s) 2 kV (1 min) - 2.2 kV (1 s)
Impulse withstand voltage (1.2/50 μs - 0.5 J) between electrically independent circuits and between these circuits and ground between open contact parts	5 kV 5 kV

Mechanical specifications	
Mechanical life expectancy	20 x 10 <sup>6</sup> operations
Maximum switching rate	3,600 operations / hour
Degree of protection (with relay mounted)	IP20
Dimensions (mm) <sup>(1)</sup>	45 x 45 x 109
Weight (g)	~ 330

<sup>(1)</sup> Excluding output terminals

Environmental specifications	
Operating temperature	Standard (14 to 131) °F (-10 to 55) °C Version for railways, rolling stock (-13 to 158) °F (-25 to 70) °C
Storage and shipping temperature	(-13 to 185) °F (-25 to 85) °C
Relative humidity	Standard: 75 % RH, Tropicalized: 95 % RH
Resistance to vibrations	5 g - 10 to 60 Hz - 1 min
Resistance to shock	30 g - 11 ms
Fire behavior	V0

Standards and reference values	
EN 61810-1, EN 61810-2, EN 61810-7	Electromechanical elementary relays
EN 61812-1	Timer relays
EN 60695-2-10	Fire behavior
EN 61000	Electromagnetic compatibility
EN 60529	Degree of protection provided by enclosures

Unless otherwise specified, the products are designed and manufactured according to the requirements of the above-mentioned European and International standards. In accordance with EN 61810-1, all items of technical data are referred to ambient temperature 23 °C, atmospheric pressure 96 kPa and 50 % humidity. Tolerance for coil resistance, nominal electrical input and nominal power is ± 7 %.

Railways, rolling stock - Standards	
EN 60077	Electric equipment for rolling stock — general service conditions and general rules
EN 50155	Electronic equipment used on rolling stock
EN 61373	Shock and vibration tests, CAT 1, Class B
EN 45545-2	Fire behavior, CAT E10, Requirement R26, V0
ASTM E162, E662	Fire behavior



## Configuration options

P2	Tropicalization of coil with epoxy resin for use with 95 % RH (@ T 50 °C). This treatment also protects the coil against corrosion which could occur by combination of the humidity with certain chemical agents, such as those found in acid atmospheres (typical of geothermal power stations) or saline atmospheres.
P4GEO	Gold plating of contacts with gold-nickel alloy, thickness $\geq 6 \mu$ . This treatment ensures long-term capacity of the contact to conduct lower currents in harsh ambient conditions such as acid atmospheres (typical of geothermal power stations) or saline atmospheres.
P5GEO	<b>P4GEO</b> gold-plating of contacts + <b>P2</b> coil tropicalization.
P6GEO	<b>P4GEO</b> type gold-plating, but applied to contacts, contact terminals and output terminals + <b>P2</b> coil tropicalization.
LED	LED indicator showing presence of power supply, wired in parallel with the coil.



## Ordering scheme

Product code	Application <sup>(1)</sup>	Configuration A	Configuration B	Label	Type of power supply	Nominal voltage (V) <sup>(2)</sup>	Full scale time	Keying position <sup>(3)</sup>
TOKe TOKr	<b>E:</b> Energy Railway Fixed Equipment  <b>R:</b> Railway Rolling Stock	4: LED (as standard)	0: Standard 2: P2 4: P4 GEO 5: P5 GEO 6: P6 GEO	F	C: V <sub>DC</sub> <sup>(4)</sup> A: V <sub>AC</sub> 50 Hz H: V <sub>AC</sub> 60 Hz	024 - 036 - 048 072 - 110 - 125 132 - 144 - 220 230	01S: 1 s 02S: 2 s 04S: 4 s 08S: 8 s 16S: 16 s 32S: 32 s 01M: 1 min 02M: 2 min 04M: 4 min 08M: 8 min 16M: 16 min 32M: 32 min 64M: 64 min	XXX

Example

<b>TOKe</b>	<b>E</b>	<b>4</b>	<b>0</b>	<b>F</b>	<b>C</b>	<b>110</b>	<b>04S</b>	
TOKeE40F-C110-04S - TOKe relay, ENERGY series, 110 V <sub>DC</sub> coil, full scale 4 seconds								
<b>TOKr</b>	<b>R</b>	<b>4</b>	<b>4</b>	<b>F</b>	<b>C</b>	<b>024</b>	<b>08M</b>	
TOKrR44F-C024-08M - TOKr relay, ROLLING STOCK series, 24V <sub>DC</sub> coil, full scale 8 minutes, with P4GEO finish (gold-plated contacts)								

<sup>(1)</sup> **E = ENERGY:** all applications, except for railways rolling stock. Suitable on energy production, transport and distribution plants, railways fixed equipment, petrochemical and heavy industry.

**R = RAILWAYS, ROLLING STOCK:** Application on board rolling stock (rail-tram-trolley vehicles). Electrical specifications according to EN 60077.

Other product series available:

**RAILWAYS, FIXED EQUIPMENT:** Approved and conforming relays and products to RFI (FS Group) specification no. RFI DPRIM STF IFS TE 143 A. For the list of RFI approved and conforming products, consult dedicated catalog "RAILWAY SERIES – RFI APPROVED".

**STATIONS:** ENEL approved material meeting LV15/LV16 specifications. For the list of ENEL approved and conforming products, consult the dedicated catalog "STATIONS SERIES – LV15-LV16-LV20".

<sup>(2)</sup> Other values on request.

<sup>(3)</sup> Optional value. The positive mechanical keying is applied according to the manufacturer's model.

<sup>(4)</sup> Rolling Stock version, V<sub>DC</sub> only available.

## Wiring diagram

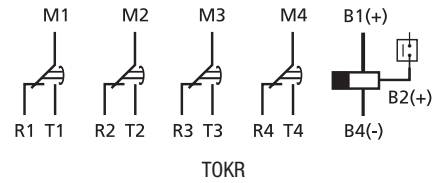
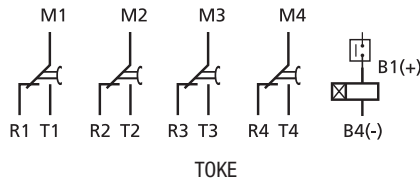

## Functional diagram

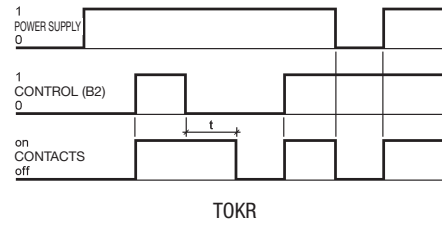
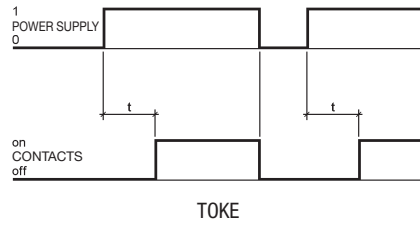

e(t): DC < 15 % / AC < 20 % of time t.

## ⌚ Time delay – Switching time setting

Time setting	By way of potentiometer, with slotted head screw
Full scale times available	1-2-4-8-16-32 seconds, 1-2-4-8-16-32-64 minutes
Time setting range	10 - 100 % of full scale <sup>(1)</sup>
Accuracy, setting (0.8...1.1 U <sub>n</sub> , t = 20 °C)	± 5 % of time delay
Accuracy, repeatability	DC: ± 0.5 % / AC: ± 0.5 % + 20 ms
Reset	< 100 ms - in time-delay phase < 1 s

<sup>(1)</sup> The time varies by the same percentage as the input voltage fluctuation, within limits of ± 10 %.

## Dimensions

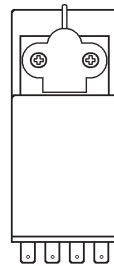
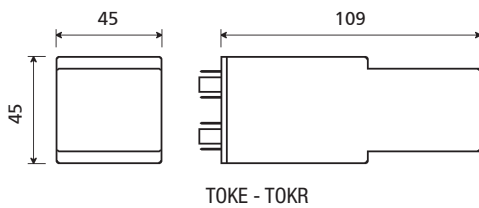

Finish for ROLLING STOCK  
version (TOK)

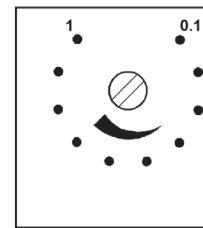

Time setting (TOK)  
The scale shown on the relay  
(0.1-1) is approximate

## Electrical life expectancy

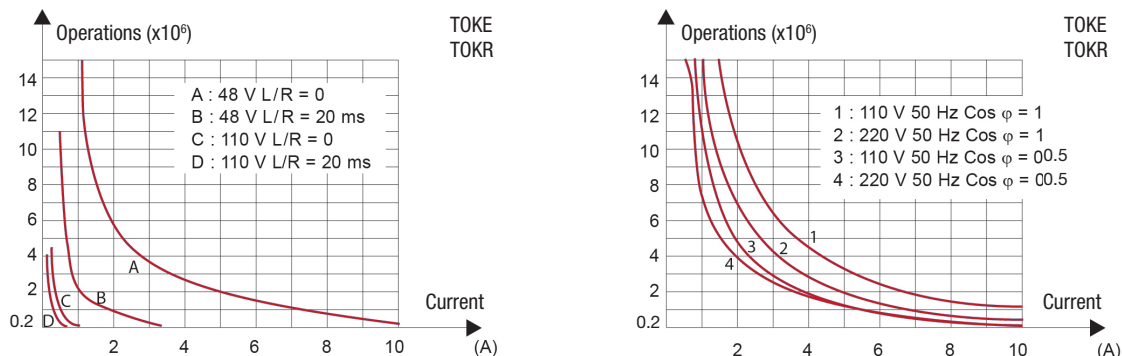

Other examples of electrical life expectancy available on the technical data sheet of the OK series relay (OKSFC model) on page 34.

## Sockets and retaining clips

Number of terminals (standard dimensions 5 x 0.8 mm)	16	Retaining clip
For wall or rail mounting		
Spring clamp, wall or DIN H35 rail mounting	PAIR160	RL48
Screw, wall or DIN H35 rail mounting	48BIP20-I DIN	RL48
Screw, wall mounting	48BL	RL48
Double faston, wall mounting	48L	RL48
For flush mounting		
Double faston (4.8 × 0.8 mm)	ADF2	RL48
Screw	43IL <sup>(1)</sup>	RL43
For mounting on PCB		
	65	RL43

<sup>(1)</sup> Insert the clip before fastening the socket on the panel.

For more details, see specifications of mounting accessories.

## Mounting tips

- The preferred mounting position is on the wall, with the relay positioned horizontally in the reading direction on the nameplate.
- For correct use of the relays, they should be spaced apart by at least 5 mm in the horizontal direction and 20 mm in the vertical direction. This is to allow correct upward dissipation of the heat generated by the coil. Set these distances according to the socket used. Distances can be reduced depending on the environmental application conditions and on the relay duty cycle.
- For safe and secure operation, it is advisable to use retaining clips.
- No special maintenance is required.
- Condensation can form inside the relay when powered up and the outside ambient temperature is cold; this is quite normal and does not affect the operation of the relay. The plastic materials of the relay do not possess hygroscopic properties.

# SOCKETS

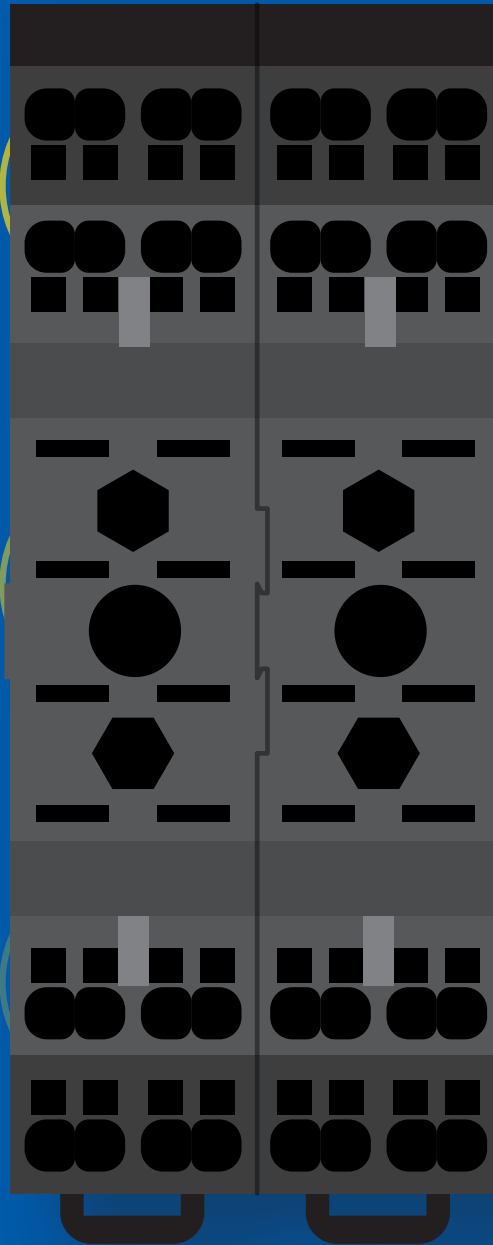

# SOCKETS

<b>EXPLANATION OF SOCKET NUMBERING</b> .....	P. 88
<b>FRONT CONNECTION</b> .....	P. 90
FRONT CONNECTION WITH SPRING CLAMP .....	P. 90
FRONT CONNECTION WITH SCREW .....	P. 92
<b>REAR CONNECTION</b> .....	P. 96
REAR CONNECTION WITH SPRING CLAMP .....	P. 96
REAR CONNECTION WITH SCREW .....	P. 100
REAR CONNECTION WITH SINGLE FASTON .....	P. 101
REAR CONNECTION WITH DOUBLE FASTON .....	P. 102
<b>MOUNTING ON PCB</b> .....	P. 106

# NUMBERING CORRESPONDENCE BETWEEN RELAYS AND SOCKETS

The relays in the “ENERGY” and “RAILWAY Rolling Stock” series have 2 types of numbering.

Specifications	Specifications Models	Example
OK numbering	OK, OKS, OKFC, OKSFC, OKSCd, OKSGcCd, OKUIC, TOK	
POK numbering	POK/POKS, BIPOK/BIPOKS, TRIPOK/TRIPOKS, TM, RCG, RDG, RGG	

QUADRIPOKS and ESAPOKS models are identified by international numbering.

- Sockets with more than 8 terminals carry both types of numbering (with the exception of the ADF series).

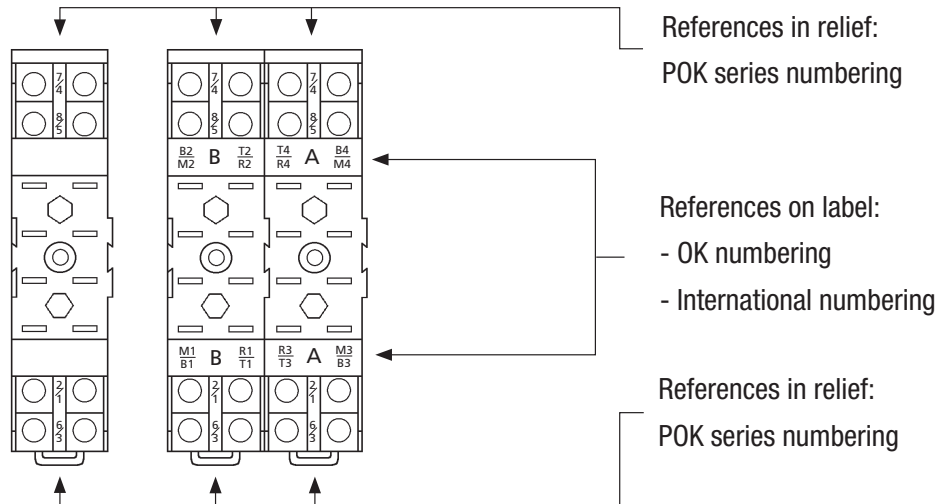

## EXAMPLE OF “OK NUMBERING”

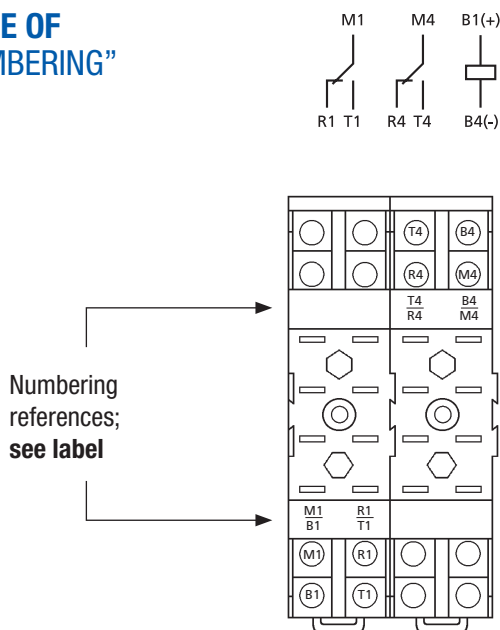

## EXAMPLE OF “POK NUMBERING”

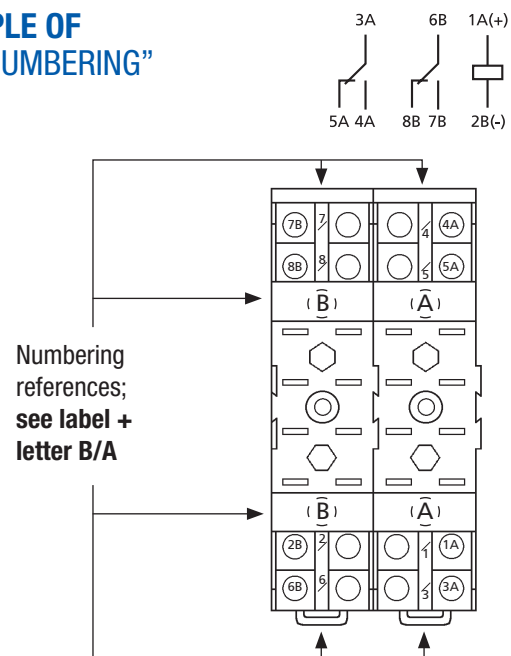





SOCKETS

## FRONT CONNECTION (WITH SPRING CLAMP)

# PAIR080 | PAIR160 | PAIR240 | PAIR320 | PAIR480

CONNECTION

FRONT

TERMINAL TYPE

SPRING CLAMP

MOUNTING

PANEL / DIN RAIL

### PRODUCT ADVANTAGES

- Cable secured with spring clamp mechanism
- Insertion of lug with no need for tools
- Quick and easy wiring, saving more than half the time taken with conventional wiring
- Mounting to panel and 35 mm DIN rail
- Excellent contact pressure on relay terminals
- Sturdy construction, no internal soldering
- Compatible with cable up to 2.5 mm<sup>2</sup>, bare (flexible or rigid) and with lug; 2 inputs per terminal
- Provision for fitment of keying pins
- Provision for fitment of retaining clip
- Protection IP20

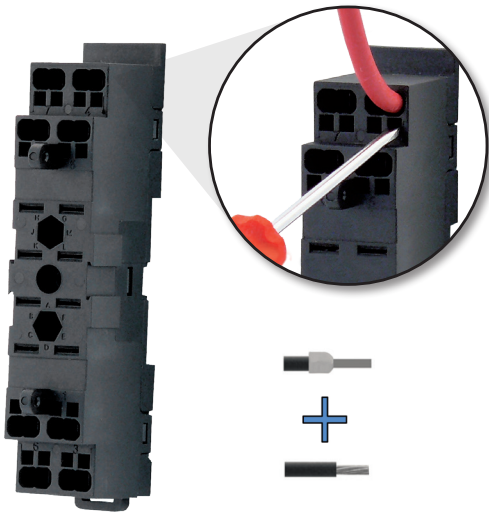

PAIR080

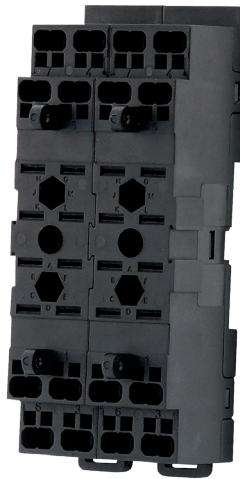

PAIR160

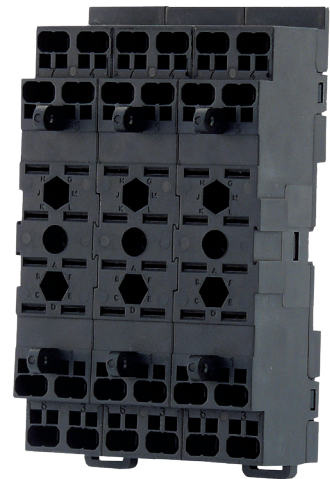

PAIR240

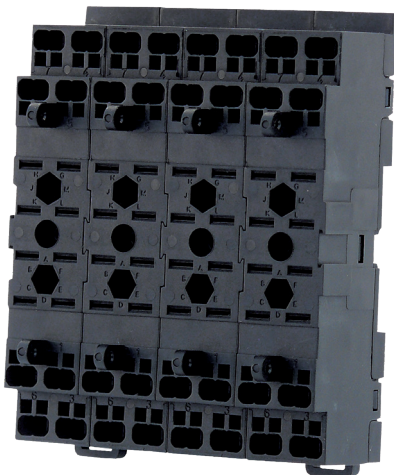

PAIR320



PAIR480

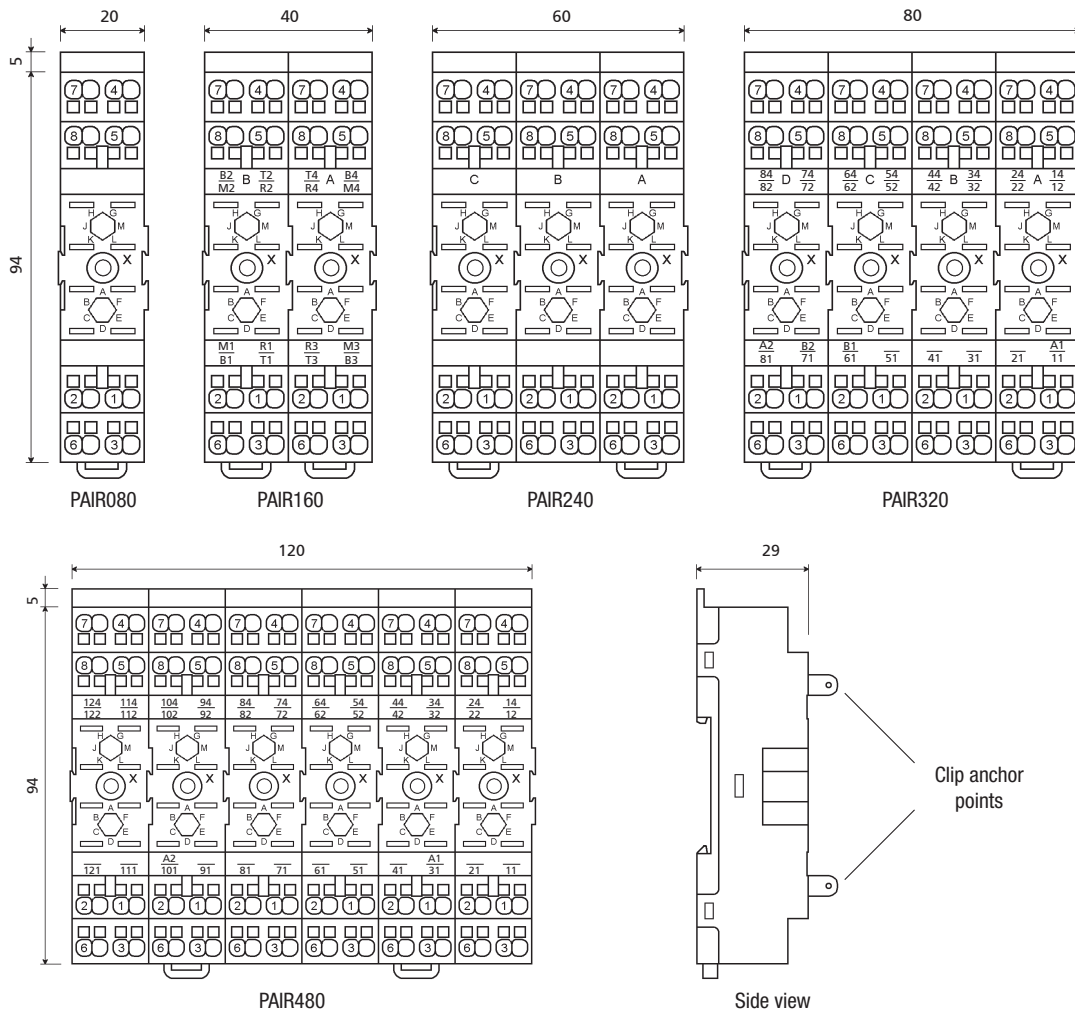

X = Fixing holes

## SPECIFICATIONS

**Weight:** 62 / 124 / 186 / 248 / 370 g

**Operating temperature:** (-58 to 158) °F (-50 to 70) °C

**Storage temperature:** (-58 to 185) °F (-50 to 85) °C

**Panel mounting:** •  $\varnothing$  holes: 3.2 mm

- center distance between adjacent holes: 20 mm

**Mounting to Omega support:** H35 to DIN 46277/3 - EN 60715 standards

**Degree of protection:** IP20

**Dielectric strength:** 2.5 kV 50 Hz 1 min

**Fire resistance:** EN 60695-2-1, UL94 - V0, EN 45545-2, NFPA 130

**Standards:** EN 60255, EN 60947, EN 61810, EN 61373

**Terminal type:** spring clamp

**Inputs for each relay terminal:** 2

**Minimum section of cable:** • cable without lug: 1 mm<sup>2</sup>  
• cable with lug: 0.5 mm<sup>2</sup>

**Maximum section of cable:** 2.5 mm<sup>2</sup>

**Wire stripping length, mm:** 10 mm  $\pm$  0.5 mm

**Length of lug:** 12 mm

**Wiring with rigid cables or lug:** pressure grip

**Wiring with flexible cables, extraction of cables:** using screwdriver type tool with slim shaft and slotted head measuring 2.5 mm x 0.4 mm, inserted perpendicularly to the socket.

### To order

PAIR080	P01 4003 55
PAIR160	P01 4003 56
PAIR240	P01 4003 57
PAIR320	P01 4003 58
PAIR480	P01 4003 64

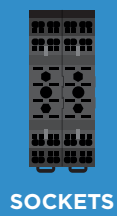

## FRONT CONNECTION (WITH SCREW)

**50IP20-I DIN | 48BIP20-I DIN | 78BIP20-I DIN |**  
**96IP20-I DIN | 156IP20-I DIN**

**CONNECTION**  
FRONT

**TERMINAL TYPE**  
SCREW

**MOUNTING**  
PANEL / DIN RAIL

### PRODUCT ADVANTAGES

- Cable secured with screws
- Mounting to panel and 35 mm DIN rail
- Sturdy construction
- Excellent contact pressure on relay terminals
- No internal soldering
- Inputs for maximum section 2.5 mm<sup>2</sup>
- Provision for fitment of keying pins
- Provision for fitment of retaining clip
- Protection IP20



50IP20-I DIN



48BIP20-I DIN



78BIP20-I DIN

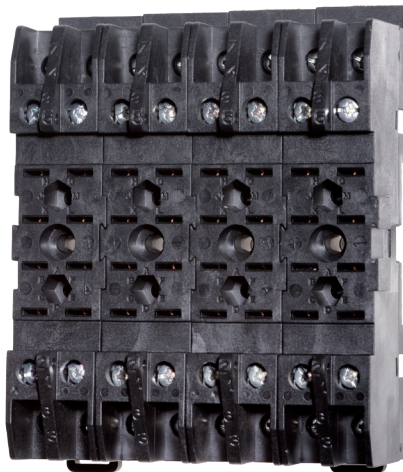

96IP20-I DIN

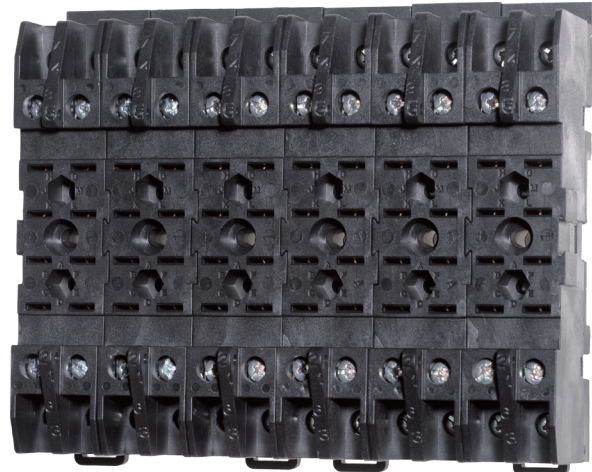

156IP20-I DIN

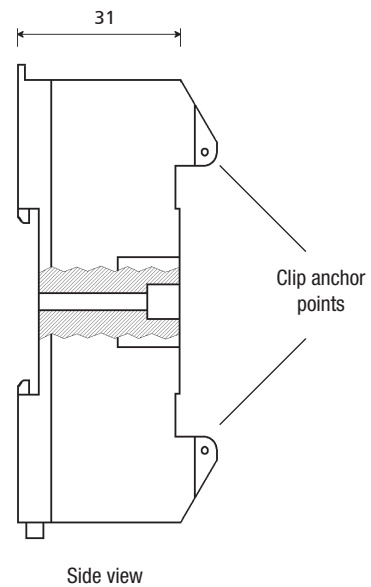
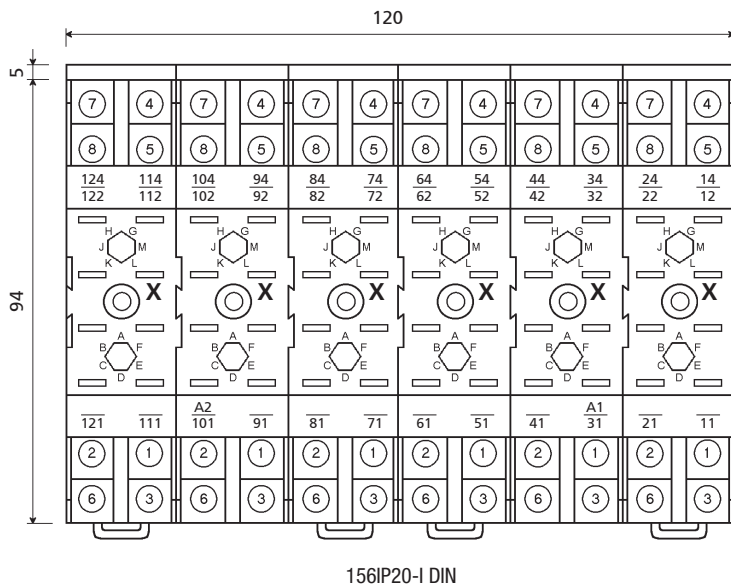
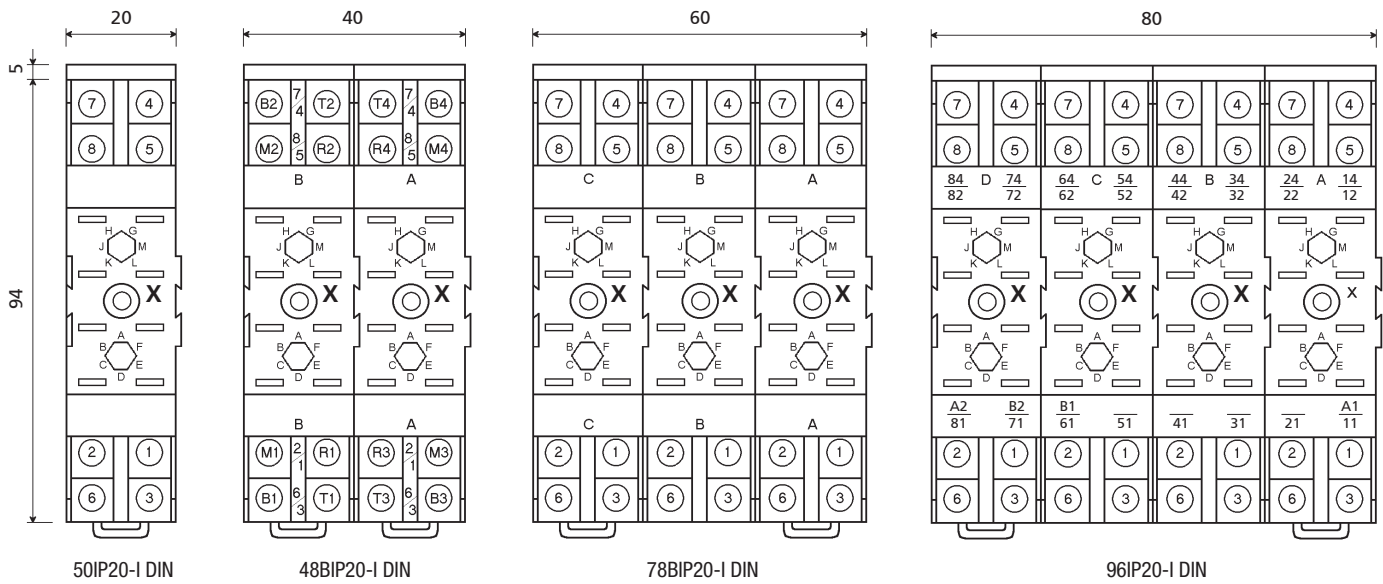

X = Fixing holes

## SPECIFICATIONS

**Weight:** 70 / 140 / 210 / 280 / 415 g

**Operating temperature:** (-58 to 158) °F (-50 to 70) °C

**Storage temperature:** (-58 to 185) °F (-50 to 85) °C

**Panel mounting:** •  $\varnothing$  holes: 4.2 mm

• center distance between adjacent holes: 20 mm

**Mounting to Omega support:** H35 to DIN 46277/3 - EN 60715 standards

**Degree of protection:** IP20

**Dielectric strength:** 2.5 kV 50 Hz 1 min

**Type and size of screw:** M3 thread, cross head

**Tightening torque:** 0.5 ... 0.6 Nm

**Width of slot:** 6.9 mm

**Maximum section of cable:** 2 x 2.5 mm<sup>2</sup>

**Fire resistance:** EN 60695-2-1, UL94 - V0, EN 45545-2, NFPA 130

**Standards:** EN 60255, EN 60947, EN 61810, EN 61373



### To order

50IP20-I DIN	P01 4002 33
48BIP20-I DIN	P01 4002 34
78BIP20-I DIN	P01 4002 35
96IP20-I DIN	P01 4002 36
156IP20-I DIN	P01 4002 37



SOCKETS

# FRONT CONNECTION (WITH SCREW)

## 50L | 48BL | 78BL | 96BL

CONNECTION

FRONT

TERMINAL TYPE

SCREW

MOUNTING

PANEL

### PRODUCT ADVANTAGES

- Cable secured with removable screws
- Panel mounting
- Sturdy construction
- Excellent contact pressure on relay terminals
- No internal soldering
- Inputs for maximum section 2.5 mm<sup>2</sup>
- Provision for fitment of keying pins
- Provision for fitment of retaining clip
- Protection IP10



50L

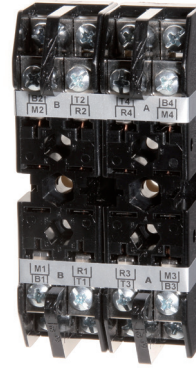

48BL

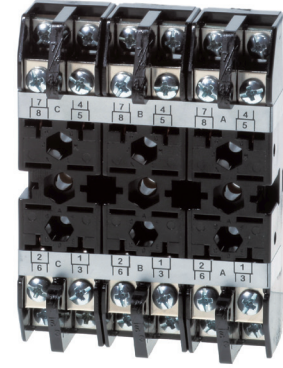

78BL

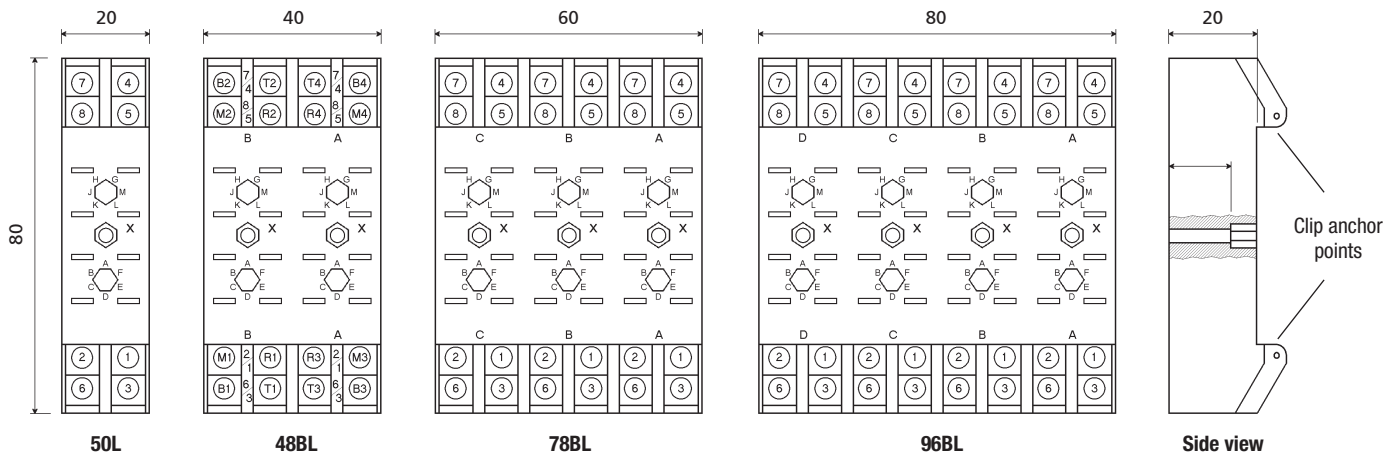

X = Fixing holes

### SPECIFICATIONS

**Weight:** 36 / 72 / 108 / 144 g

**Operating temperature:** (-13 to 158) °F (-25 to 70) °C

**Storage temperature:** (-40 to 185) °F (-40 to 85) °C

**Panel mounting:** • ø holes: 4.2 mm

• center distance between adjacent holes: 20 mm

**Degree of protection:** IP10

**Dielectric strength:** 2.5 kV 50 Hz 1 min

**Type and size of screw:** M3 thread, cross head

Removable screw for use with eyelet terminals

**Tightening torque:** 0.5 ... 0.8 Nm

**Width of slot:** 7.1 mm

**Maximum section of cable:** 2 x 2.5 mm<sup>2</sup>

**Fire resistance:** EN 60695-2-1, UL94 - V0, EN 45545-2, NFPA 130

**Standards:** EN 60255, EN 60947, EN 61810, EN 61373



To order

50L	P01 4002 10
48BL	P01 4002 04
78BL	P01 4002 07
96BL	P01 4002 03





SOCKETS

## REAR CONNECTION (WITH SPRING CLAMP)

# PRIR08x | PRIR16x | PRIR24x | PRIR32x | PRIR48x

CONNECTION

REAR

TERMINAL TYPE

SPRING CLAMP

MOUNTING

PANEL

### PRODUCT ADVANTAGES

- Cable secured with spring clamp mechanism
- Insertion of cable with no need for tools
- Quick and easy wiring, saving more than half the time taken with conventional wiring
- Panel mounting
- Excellent contact pressure on relay terminals
- Sturdy construction, no internal soldering
- Compatible with cable up to 2.5 mm<sup>2</sup>, bare (flexible or rigid) and with lug; 2 inputs per terminal
- Provision for fitment of keying pins
- Provision for fitment of retaining clip
- Protection IP20



PRIR08x



PRIR16x

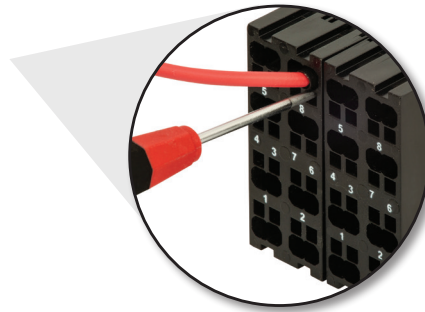

Detail of connections



PRIR24x



PRIR32x

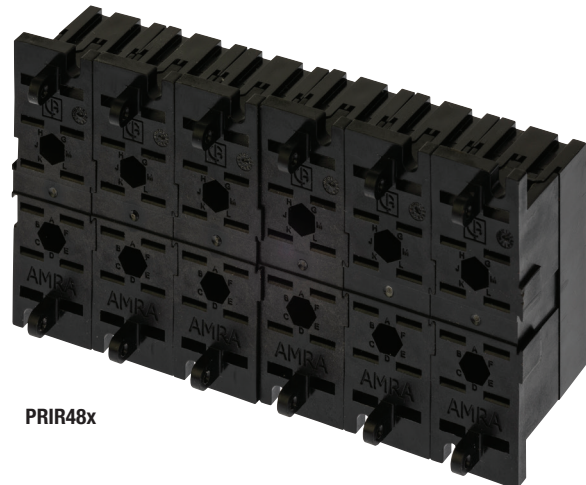

PRIR48x

# PRIR08x

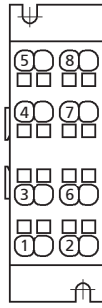
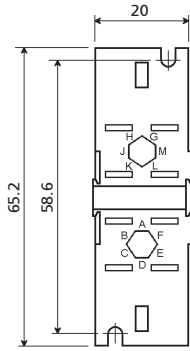

**PRIR080**  
Rear view

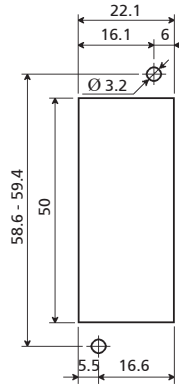

Drilling template

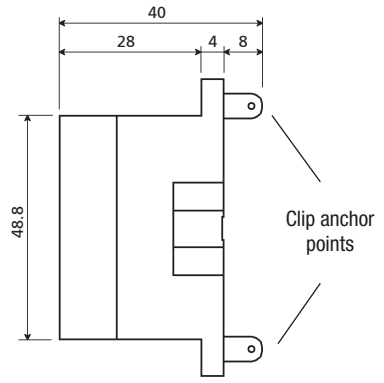

Side view

Clip anchor points

# PRIR16x

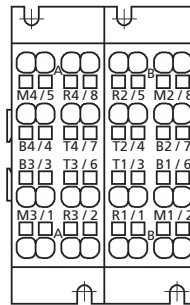
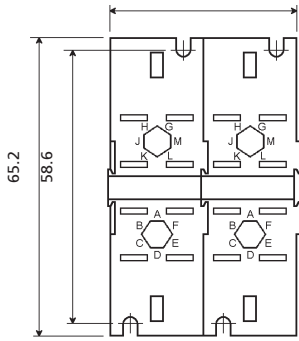

**Rear view**  
PRIR160

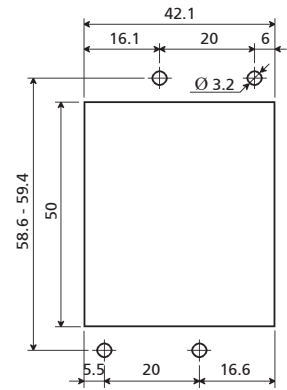

Drilling template

# PRIR24x

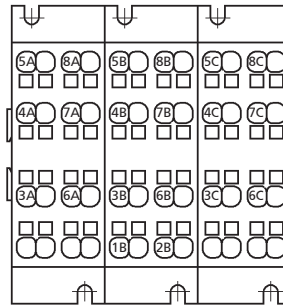
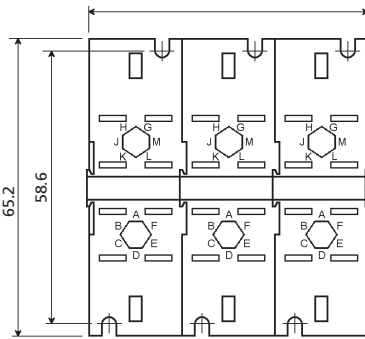

**PRIR240**  
Model with "TRIPOK" numbering  
Rear view

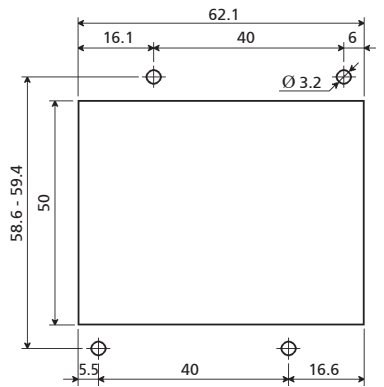

Drilling template

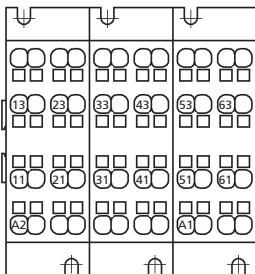

**PRIR241**  
Model with numbering for RVLV16/1

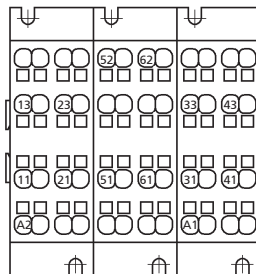

**PRIR242**  
Model with numbering for RVLV16/2

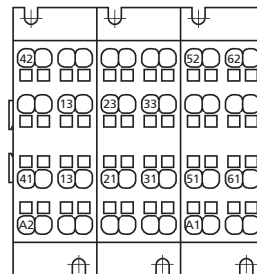

**PRIR243**  
Model with numbering for RVLV16/3

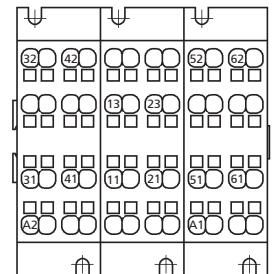

**PRIR244**  
Model with numbering for RVLV16/5

MONOSTABLE  
INSTANTANEOUS MONOSTABLE WITH FORCIBLY GUIDED CONTACTS  
TIME DELAY (ON PICK-UP OR DROP-OUT)  
EXPLANATION OF SOCKET NUMBERING  
FRONT CONNECTION  
BACK CONNECTION  
PCB MOUNT  
RETAINING CLIPS  
KEYING PINS

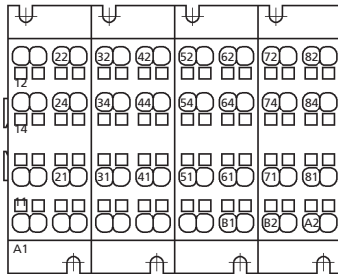
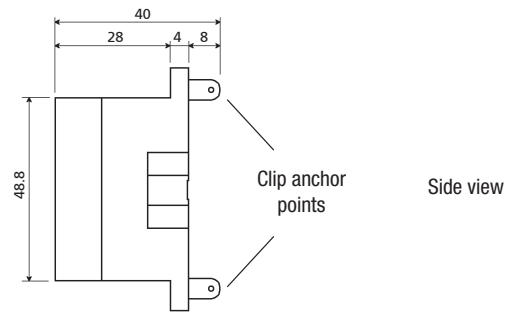
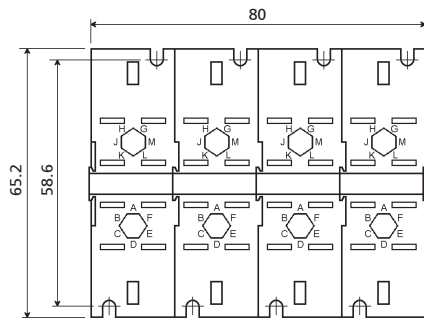

PRIR320 Rear view

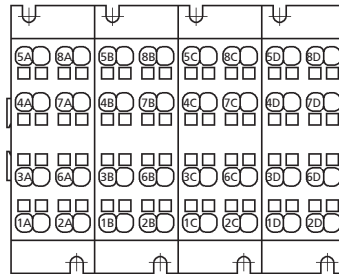

PRIR321 Rear view

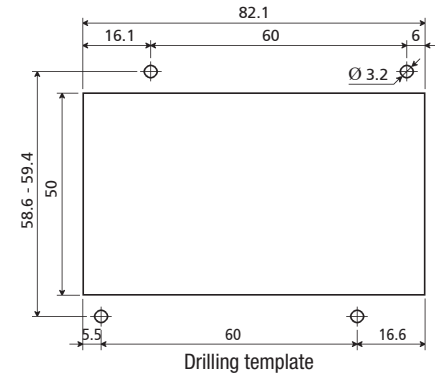

Drilling template

PRIR48x

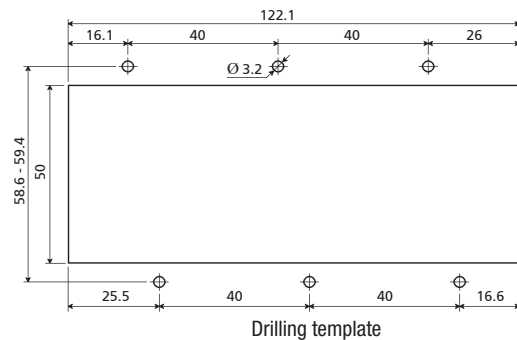
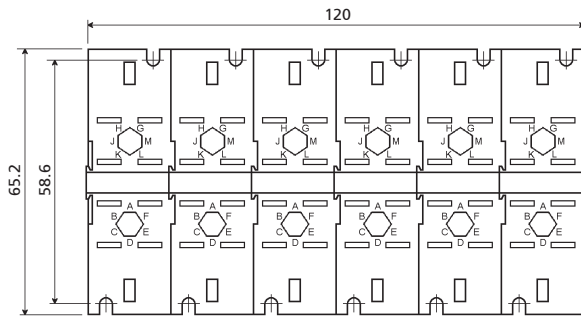

Drilling template

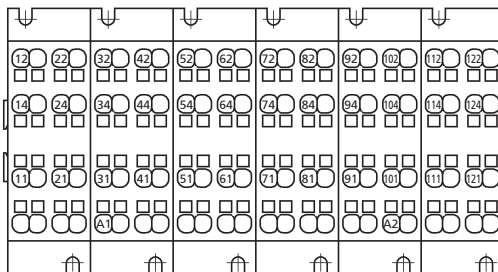

PRIR480 / Model with "ESAPOK" numbering

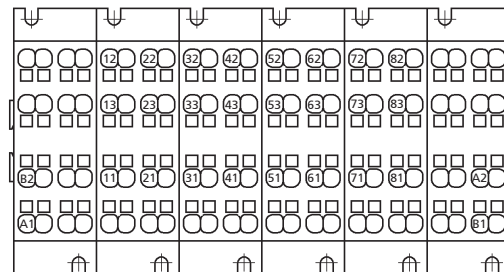

PRIR481 / Model with "BAS8NB" numbering

SPECIFICATIONS

**Weight:** 35 / 70 / 105 / 140 / 210 g  
**Operating temperature:** (-58 to 158) °F (-50 to 70) °C  
**Storage temperature:** (-58 to 185) °F (-50 to 85) °C  
**Panel mounting:**  $\varnothing$  holes: 3.2 mm  
**Degree of protection:** IP20  
**Dielectric strength:** 2.5 kV 50 Hz 1 min  
**Fire resistance:** EN 60695-2-1, UL94 - V0, EN 45545-2, NFPA 130  
**Standards:** EN 61810, EN 61373  
**Terminal type:** spring clamp  
**Inputs for each relay terminal:** 2

**Minimum section of cable:**  
 • cable without lug: 1 mm<sup>2</sup>  
 • cable with lug: 0.5 mm<sup>2</sup>  
**Maximum section of cable:** 2.5 mm<sup>2</sup>  
**Wire stripping length, mm:** 10 mm  $\pm$  0.5 mm  
**Length of lug:** 12 mm  
**Wiring with rigid cables or lug:** pressure grip  
**Wiring with flexible cables, extraction of cables:** using screwdriver type tool with slim shaft and slotted head measuring 2.5 mm x 0.4 mm, inserted perpendicularly to the socket.



To order

PRIR080	P01 4002 60
PRIR160	P01 4002 61
PRIR240	P01 4002 62
PRIR320	P01 4002 63
PRIR480	P01 4002 64





SOCKETS

# REAR CONNECTION (WITH SCREW)

## 53IL | 43IL | 73IL

CONNECTION

REAR

TERMINAL TYPE

SCREW

MOUNTING

PANEL

### PRODUCT ADVANTAGES

- Cable secured with removable screws
- Panel mounting
- Sturdy construction
- Excellent contact pressure on relay terminals
- No internal soldering
- Inputs for maximum section 2.5 mm<sup>2</sup>
- Provision for fitment of keying pins
- Provision for fitment of retaining clip
- Protection IP10

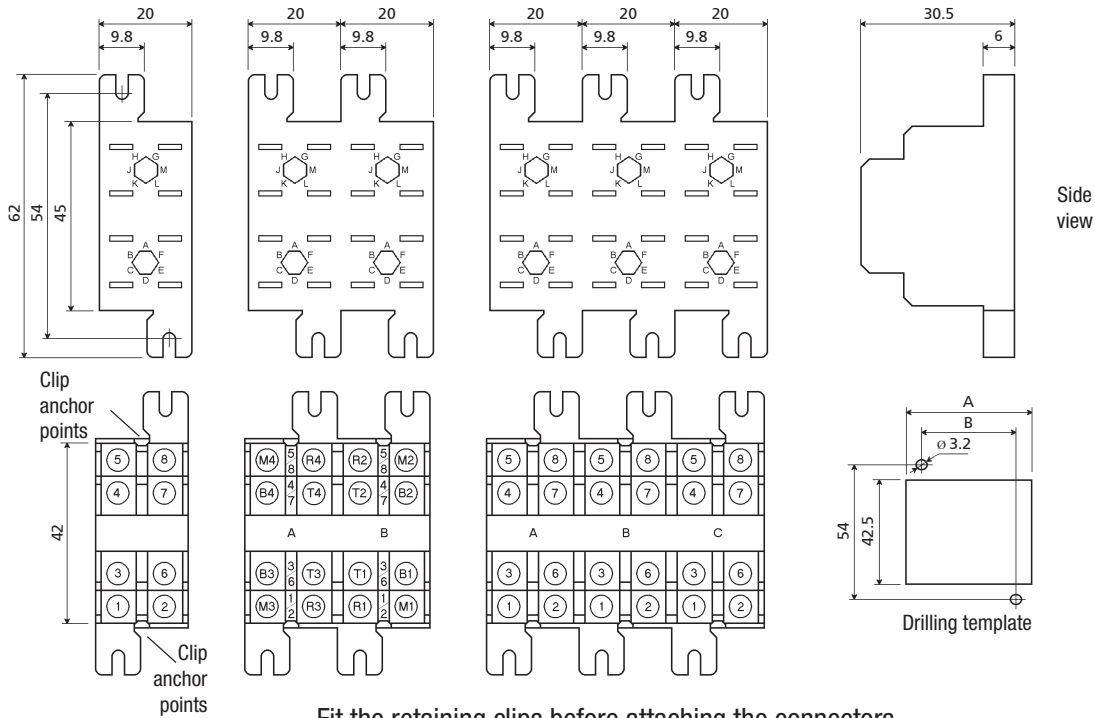
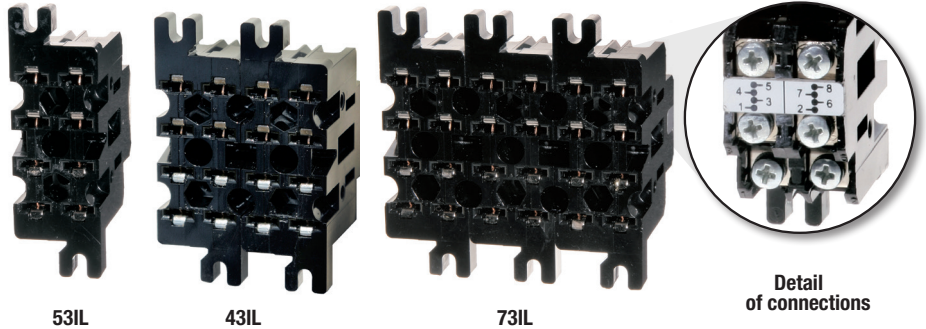

	A	B
53IL	20.5	10
43IL	40.5	30
73IL	60.5	50

### SPECIFICATIONS

**Weight:** 41 / 82 / 123 g  
**Operating temperature:** (-13 to 158) °F (-25 to 70) °C  
**Storage temperature:** (-40 to 185) °F (-40 to 85) °C  
**Degree of protection:** IP10  
**Dielectric strength:** 2.5 kV 50 Hz 1 min  
**Type and size of screw:** M3 thread, cross head  
 Removable screw for use with eyelet terminals

**Tightening torque:** 0.5 ... 0.8 Nm  
**Width of slot:** 5.4 mm  
**Maximum section of cable:** 2 x 2.5 mm<sup>2</sup>  
**Fire resistance:** EN 60695-2-1, UL94 - V0, EN 45545-2, NFPA 130  
**Standards:** EN 60255, EN 60947, EN 61810, EN 61373

To order	
53IL	P01 4002 40
43IL	P01 4002 41
73IL	P01 4002 42



SOCKETS

# REAR CONNECTION (SINGLE FASTON)

# 84F

MONOSTABLE

INSTANTANEOUS MONOSTABLE WITH FORCIBLY GUIDED CONTACTS

TIME DELAY (ON PICK-UP OR DROP-OUT)

EXPLANATION OF SOCKET NUMBERING

FRONT CONNECTION

BACK CONNECTION

PCB MOUNT

RETAINING CLIPS

KEYING PINS

**CONNECTION**  
REAR

**TERMINAL TYPE**  
FASTON

**MOUNTING**  
PANEL

## PRODUCT ADVANTAGES

- Sturdy construction
- No internal soldering

## Dimensions

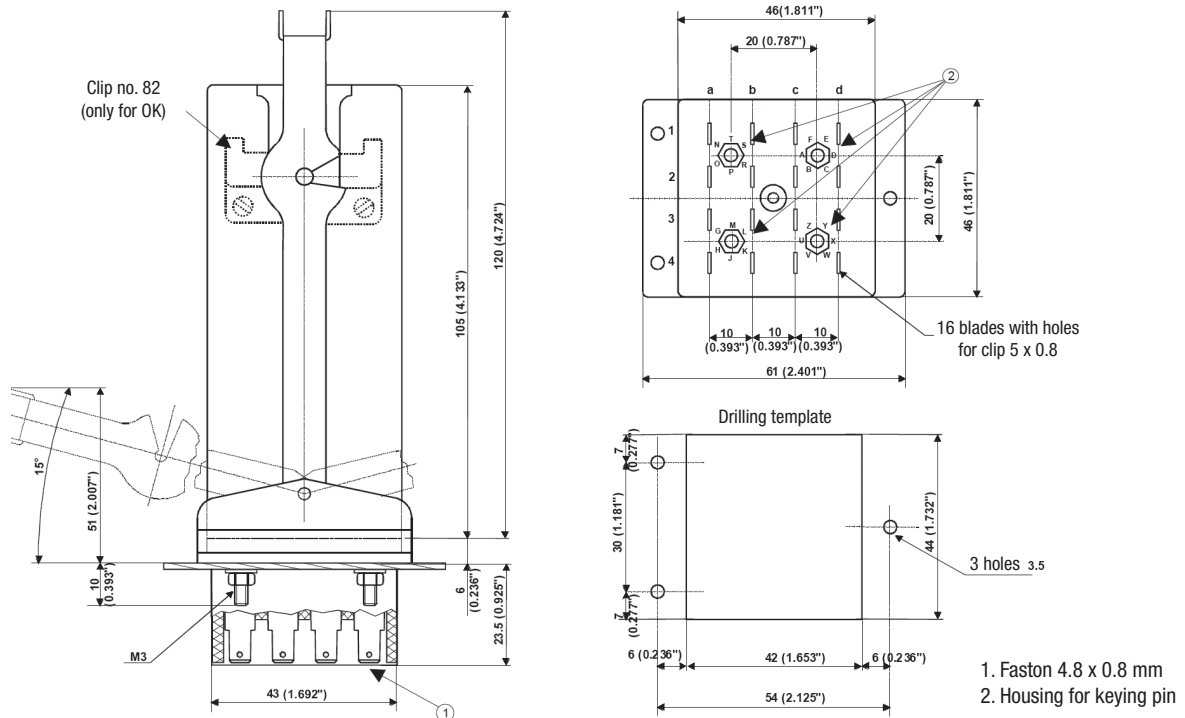

## SPECIFICATIONS

**Weight:** 120 g

**Operating temperature:** (-40 to 158) °F (-40 to 70) °C



To order

84F	ACC.84F
ADAPTER KIT N82	P01 4002 11



SOCKETS

## REAR CONNECTION (WITH DOUBLE FASTON)

# ADF1 | ADF2 | ADF3 | ADF4 | ADF6

CONNECTION

REAR

TERMINAL TYPE

FASTON

MOUNTING

PANEL

### PRODUCT ADVANTAGES

- Connection of cable with faston clip
- 2 inputs for each relay terminal
- Sturdy construction
- Excellent contact pressure on relay terminals
- No internal soldering
- Provision for fitment of keying pins
- Provision for fitment of retaining clip
- Protection IP20



ADF1

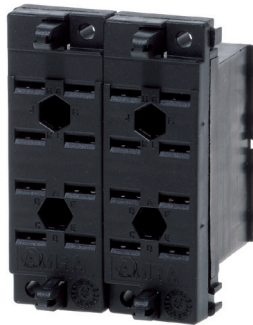

ADF2

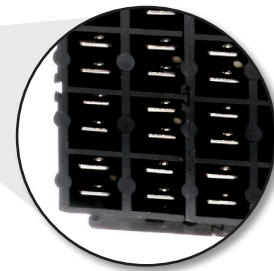

Detail of connections



ADF3



ADF4

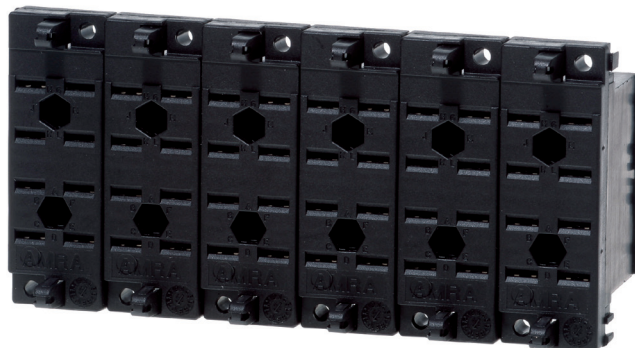

ADF6

## ADF1

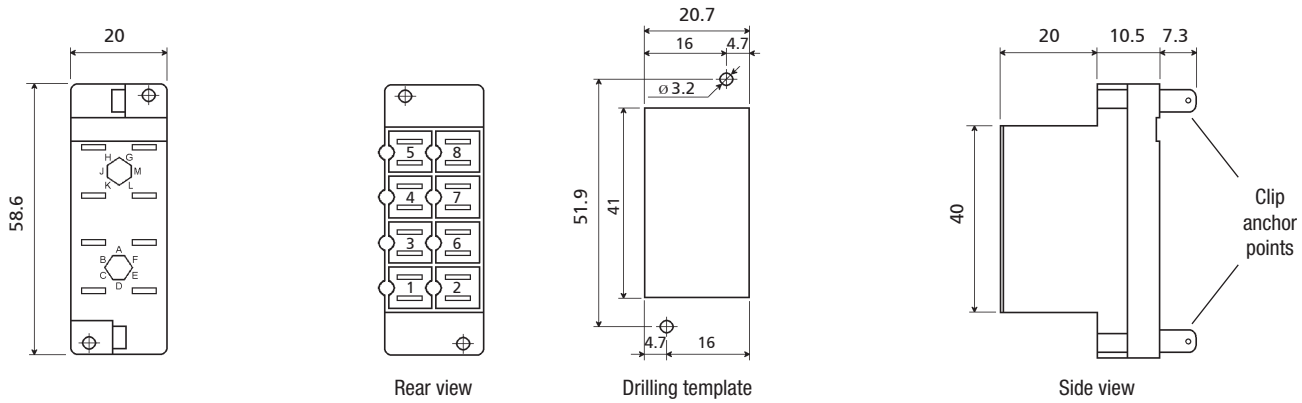

## ADF2

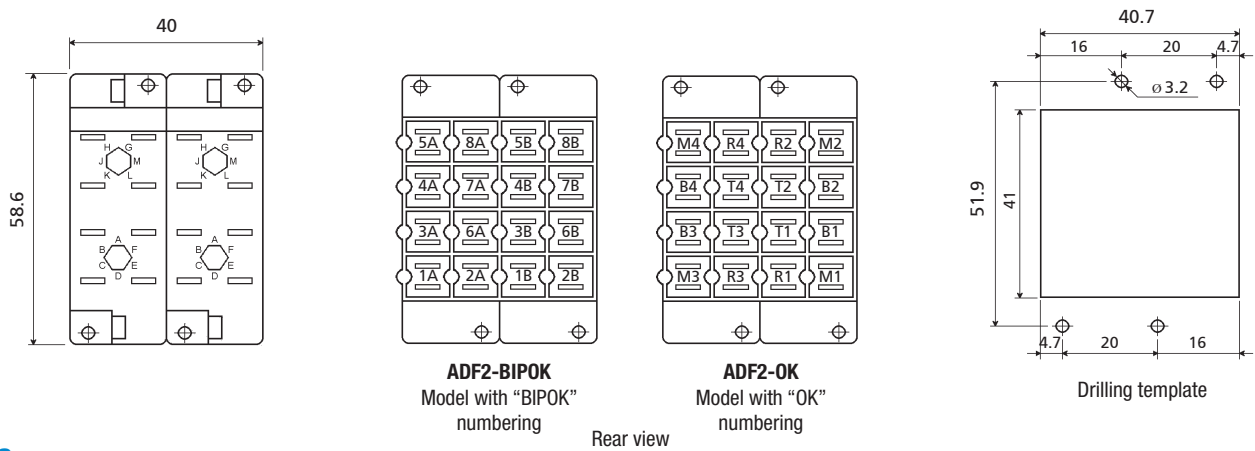

## ADF3

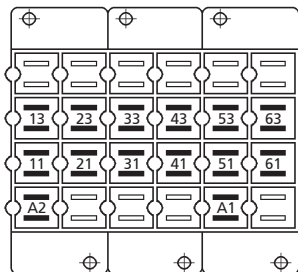
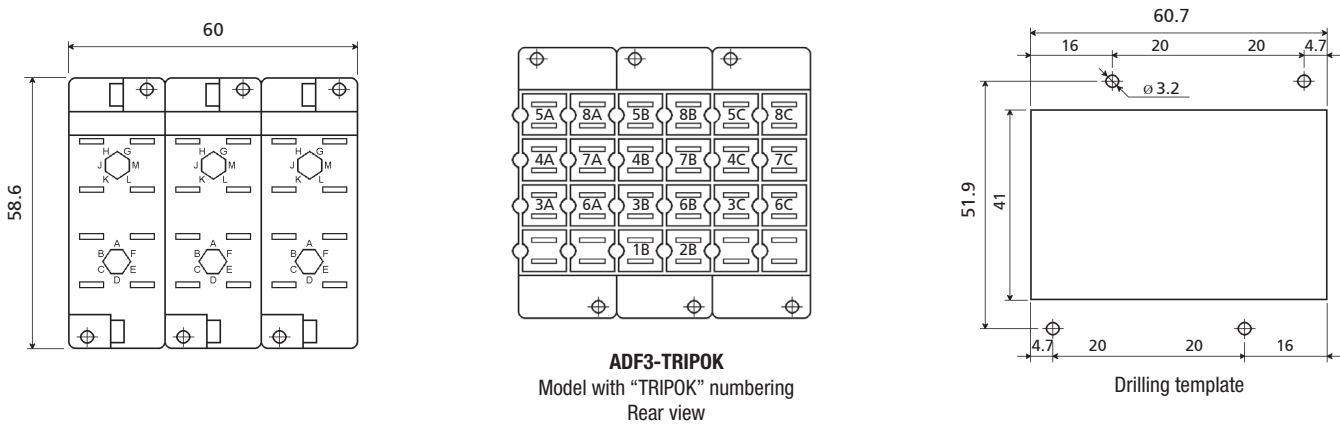

ADF3-RVLV16/1  
Model with numbering for RVLV16/1

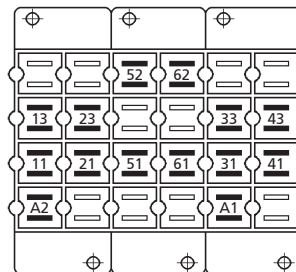

ADF3-RVLV16/2  
Model with numbering for RVLV16/2

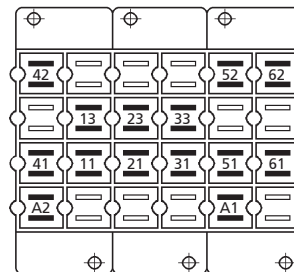

ADF3-RVLV16/3  
Model with numbering for RVLV16/3

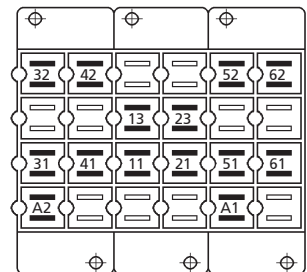

ADF3-RVLV16/5  
Model with numbering for RVLV16/5

MONOSTABLE

INSTANTANEOUS MONOSTABLE WITH FORCIBLY GUIDED CONTACTS

TIME DELAY MONOSTABLE (ON PICK-UP OR DROP-OUT)

EXPLANATION OF SOCKET NUMBERING

FRONT CONNECTION

BACK CONNECTION

PCB MOUNT

RETAINING CLIPS

KEYING PINS

## ADF4

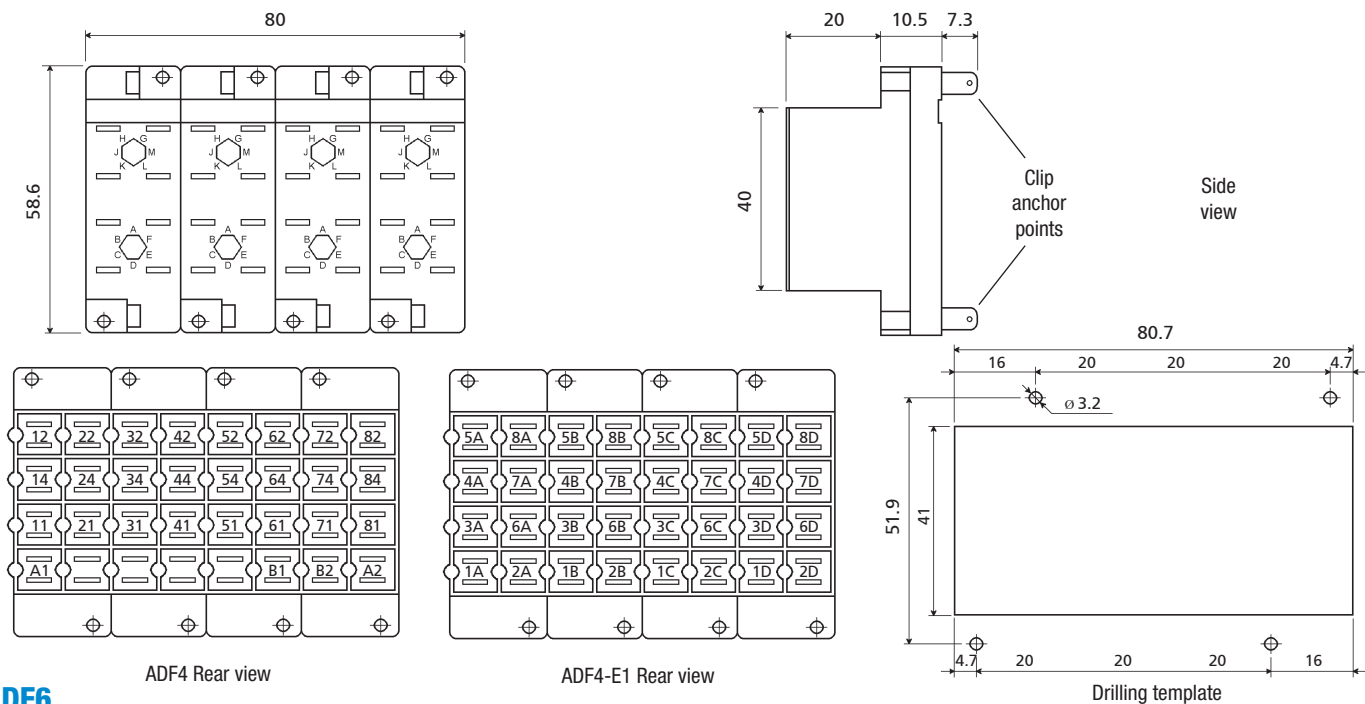

## ADF6

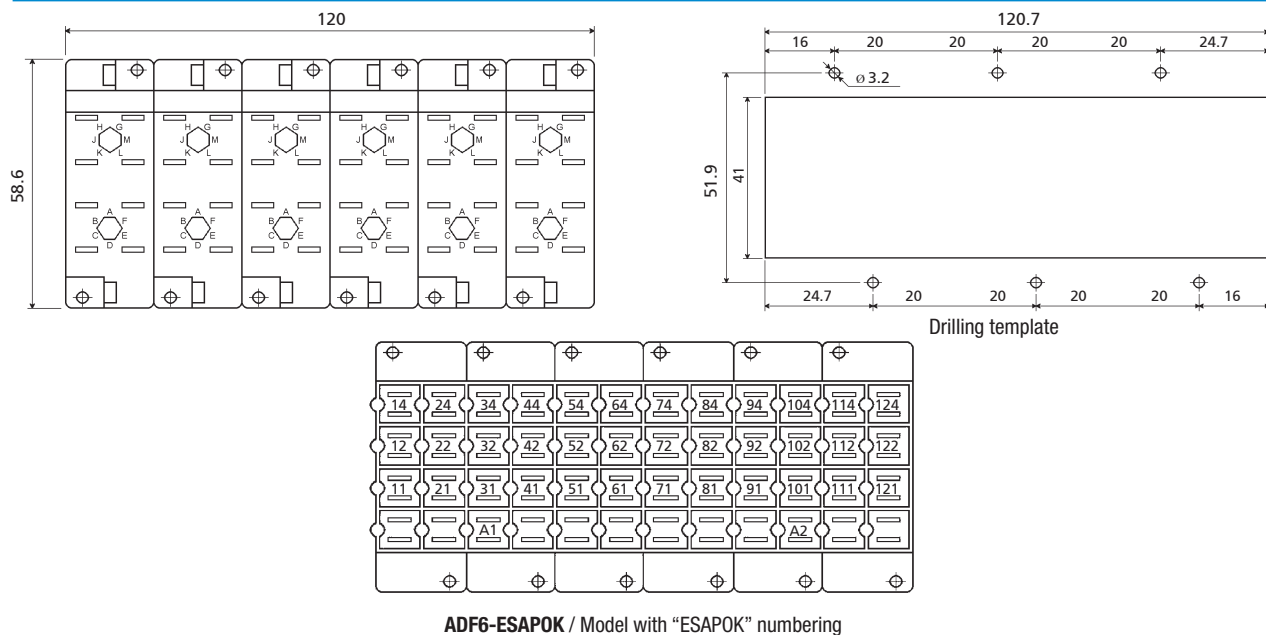

## SPECIFICATIONS

**Weight:** 32 / 64 / 96 / 128 / 192 g  
**Operating temperature:** (-13 to 158) °F (-25 to 70) °C  
**Storage temperature:** (-40 to 185) °F (-40 to 85) °C  
**Degree of protection:** IP10  
**Dielectric strength:** 2.5 kV 50 Hz 1 min  
**Type and size of faston clip:** 2 × 4.8 × 0.8  
**Width of slot:** 8 mm  
**Maximum section of cable:** 2.5 mm<sup>2</sup>  
**Fire resistance:** EN 60695-2-1, UL94 - V0, EN 45545-2  
**Standards:** EN 60255, EN 60947, EN 61810, EN 61373

### To order

ADF1	P01 4002 50
ADF2 - OK (UTM)	P01 4002 51
ADF2 - BIPOK	P01 4002 52
ADF3 - TRIPOK	P01 4002 53
ADF3 - RVLV16/1	P01 4002 54
ADF3 - RVLV16/2	P01 4002 55
ADF3 - RVLV16/3	P01 4002 56
ADF3 - RVLV16/5	P01 4002 57
ADF4	P01 4002 59
ADF6	P01 4002 58





SOCKETS

## SOCKET FOR PCB MOUNTING

# SOCKET NO. 65

CONNECTION

REAR

TERMINAL TYPE

SOLDER

MOUNTING

PCB

### PRODUCT ADVANTAGES

- PCB-mount
- Sturdy construction
- Excellent contact pressure on relay terminals
- No internal soldering
- No maintenance
- Provision for fitment of keying pins
- Provision for fitment of retaining clip

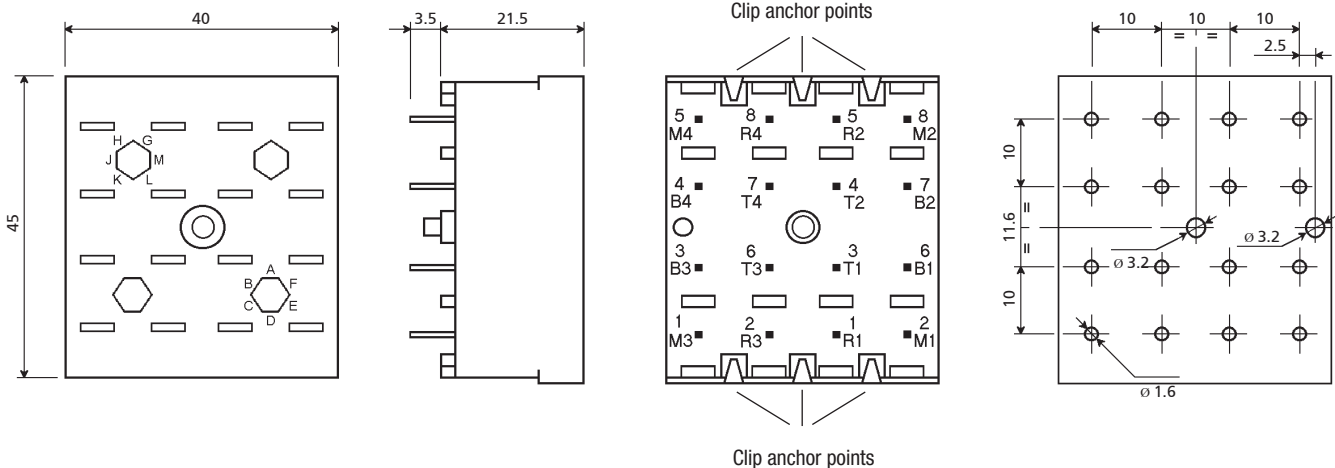
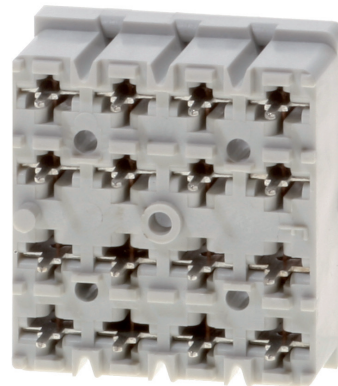

### SPECIFICATIONS

**Weight:** 51 g

**Operating temperature:** (-13 to 158) °F (-25 to 70) °C

**Storage temperature:** (-40 to 185) °F (-40 to 85) °C

**Dielectric strength:** 2.5 kV 50 Hz 1 min

**Type and size of terminals:** solder,  $\varnothing$  1.6 mm

**Fire resistance:** EN 60695-2-1, UL94 - V0,

EN 45545-2, NFPA 130

**Standards:** EN 60255, EN 60947, EN 61810,

EN 61373

To order

65

P01 4001 53A



RETAININGCLIPS

RETAININGCLIPS

RETAININGCLIPS

RETAININGCLIPS

RETAININGCLIPS



# RETAINING CLIPS

INSTANTANEOUS  
MONOSTABLE

INSTANTANEOUS  
MONOSTABLE WITH  
FORCIBLY GUIDED CONTACTS

TIME DELAY  
(ON PICK-UP  
OR DROP-OUT)

EXPLANATION OF  
SOCKET NUMBERING

FRONT  
CONNECTION

BACK  
CONNECTION

PCB MOUNT

RETAINING CLIPS

KEYING PINS

## PRODUCT ADVANTAGES

The designation of retaining clips is made up of two parts:

	1 <sup>st</sup> part: 2 or 3 letters	2 <sup>nd</sup> part: 2 numbers
	Identifies the type of relay	Identifies the model of socket
Example	<b>RPB</b>	<b>48</b>



1 <sup>st</sup> part:	Type of relay	2 <sup>nd</sup> part:	Socket model
RPB	Relays with cover, height 50 mm (POKs, UTM series)	43	53IL, 43IL, 73IL, 65
RQ	Relays with cover, height 61 mm (QPOK)	48	PAIR, PRIR, 50IP20-I DIN, 48BIP20-I DIN, 78BIP20-I DIN, 96IP20-I DIN, 156IP20-I DIN, 50L, 48BL, 78BL, 96L ADF1, ADF2, ADF3, Series ADF4, ADF6
RG	Relays with cover, height 86 mm (RGG series)		
RC	Relays with cover, height 97 mm (OK series)		
RL	Relays with cover, height 109 mm (OK series)		
RT	Timer relays with cover, height 97 mm	31	PAIR, PRIR, 50IP20-I DIN, 48BIP20-I DIN, Series 50L, 48BL, ADF1, ADF2
RM	Relays with cover, height 118 mm (MOK series)	41	53IL, 43IL, 65
VM18	Relays RCG, RDG		

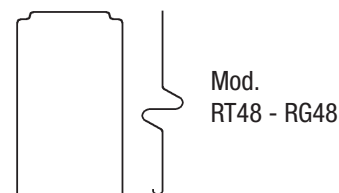
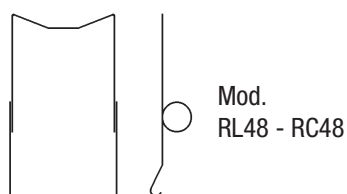
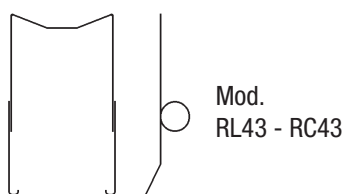
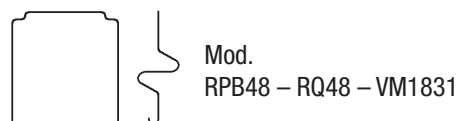
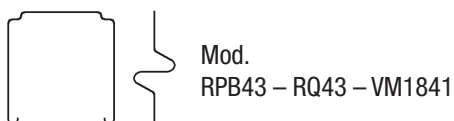

## G, C & D LINE RETAINING CLIPS

The designation of retaining clips is made up of two parts:

	1 <sup>st</sup> part: 4 characters	2 <sup>nd</sup> part: 2 numbers
	Identifies the line	Identifies the relay size
Example	<b>VM12</b>	<b>21</b>



1 <sup>st</sup> part:	Relay line	2 <sup>nd</sup> part:	Relay size
VM12	Relays of G line → all RGxx models	21	Relays of 82 mm height
		22	Relays of 112 mm height
VM18	Relays of C and D line → all RCxx and RDxx models (Except RCG, RDG)	21	Relays of 50 mm height
		22	Relays of 75 mm height
		23	Relays of 82 mm height

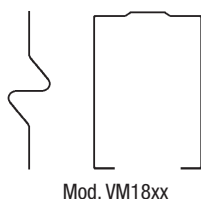
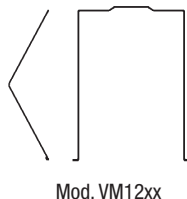

Note: Dimensions not to scale. The height of the clip varies according to the height of the relay.  
Pack containing 10 pieces.

**To order**

<b>VM12</b>	
VM1221	P01400333
VM1222	P01400334

<b>VM18</b>	
VM1821	P01400330
VM1822	P01400329
VM1823	P01400331

<b>RCG, RDG</b>	
VM1831	P01400335
VM1841	P01400336

<b>RPB</b>	
RPB43	P01400159
RPB48	P01400158
RPB48-UTM	P01400165

<b>RQ</b>	
RQ48	P01400180

<b>RG</b>	
RG43	P01400166
RG48	P01400167

<b>RC</b>	
RC43	P01400161
RC48	P01400179

<b>RL</b>	
RL43	P01400164
RL48	P01400187

<b>RT</b>	
RT43	P01400169
RT48	P01400170

<b>RM</b>	
RM43	P01400133
RM48	P01400134

<b>RMC48</b>	
RMC48	P01400173

INSTANTANEOUS  
MONOSTABLEINSTANTANEOUS  
MONOSTABLE WITH  
FORCIBLY GUIDED CONTACTSTIME DELAY  
(ON PICK-UP  
OR DROP-OUT)EXPLANATION OF  
SOCKET NUMBERINGFRONT  
CONNECTIONBACK  
CONNECTION

PCB MOUNT

RETAINING CLIPS

KEYING PINS

# POSITIVE MECHANICAL KEYING

# POSITIVE MECHANICAL KEYING

# POSITIVE MECHANICAL KEYING

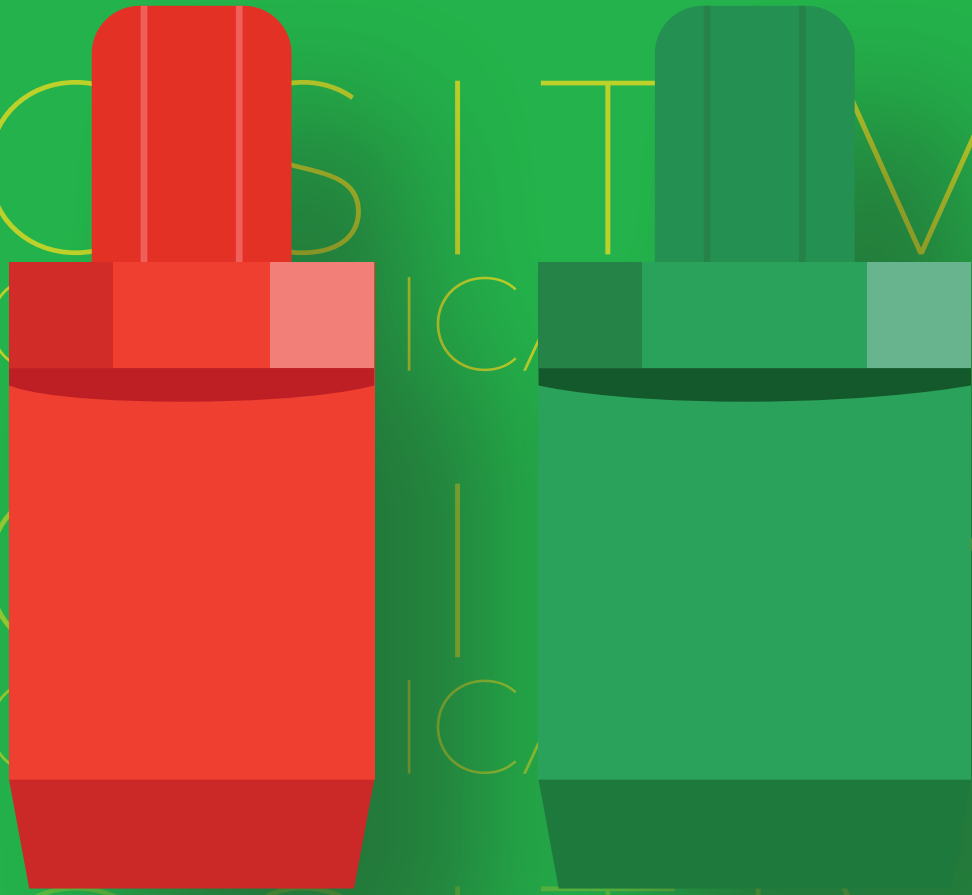

# POSITIVE MECHANICAL KEYING



# KEYING PINS

INSTANTANEOUS MONOSTABLE  
INSTANTANEOUS MONOSTABLE WITH FORCIBLY GUIDED CONTACTS  
TIME DELAY (ON PICK-UP OR DROP-OUT)  
EXPLANATION OF SOCKET NUMBERING  
FRONT CONNECTION  
BACK CONNECTION  
PCB MOUNT  
RETAINING CLIPS

# POSITIVE MECHANICAL KEYING (POLARIZING PINS)

Relay line	Ordering code	
OK, POK, RV	59	
Rxx	VC1705	

Keying pins are mechanical components of semi-hexagonal shape, designed to prevent a given relay from being plugged into a socket intended for a different component. The keying configuration is determined by fitting the pins both to the relay and to the socket, in positions identified by a dedicated code.

The hexagonal geometry of the receptacle allows the polarizing pins to be inserted in six different positions.

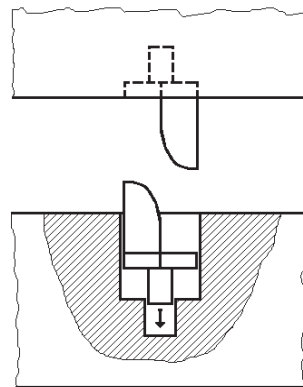

Polarizing pin on relay

Polarizing pin on socket,  
to be fitted by the customer

Whilst the use of this component is optional, it is nonetheless strongly recommended where there are multiple relays installed on an electrical panel, for example:

- two or more relays of the same model but with different input voltages
- two or more timer relays with different response and/or logic operating times (e.g. timed to operate on pick-up and timed to operate on drop-out)
- two or more instantaneous relays of different type (e.g. monostable and bistable)

In these cases, the adoption of keying position accessories will prevent any accidental inversion of the relays by the operator, which would risk damage to the system and to the components themselves, as well as jeopardizing safety.

## FITMENT AND POSITION

Relays of standard design are not equipped with these accessories.

The mounting position of polarizing pins, if requested, is determined by the manufacturer.

Keying pins for sockets are fitted normally by the customer.

In this case, keying accessories for application to the socket are ordered separately.

The following relays are supplied with pins fitted in positions determined by the manufacturer:

- STATIONS series, approved by ENEL / TERNA Italia to LV15/LV16/20 specifications
- RAILWAYS - FIXED EQUIPMENT series, approved by RFI (FS Italia Group) to RFI DPRIM STF IFS TE 143 A specification
- RAILWAYS - ROLLING STOCK series

# POSITIONS OBTAINABLE IN HEXAGONAL RECEPTACLES

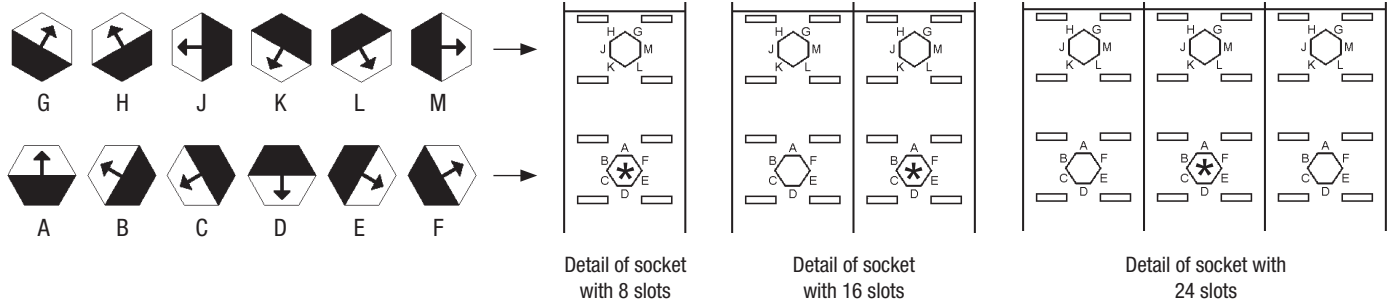

\*: receptacle to be left free in the event that the relay is fitted with an anti-rotation pin.

In the case of polarized input (e.g. with flyback diode), the relay is fitted with an anti-rotation pin (diagram below).

The anti-rotation pin is always fitted to the following relays:

POK, BIPOK, TRIPOK, QUADRIPOK, ESAPOK.

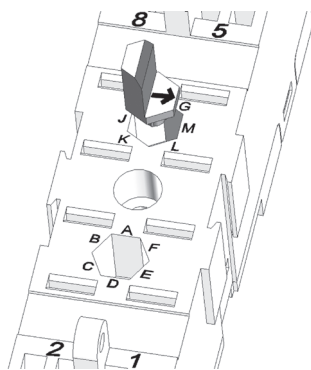

Example of selection, pos. M on socket with 8 slots

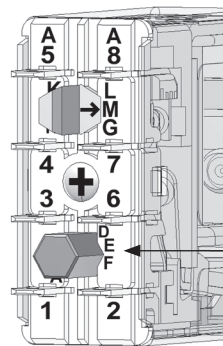

Example of selection, pos. M on POK relay

Anti-rotation pin

## C line

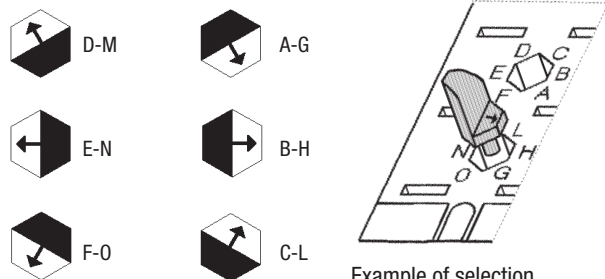

Example of selection, pos. H

2 hexagonal receptacles available on relay and on socket.

## D line

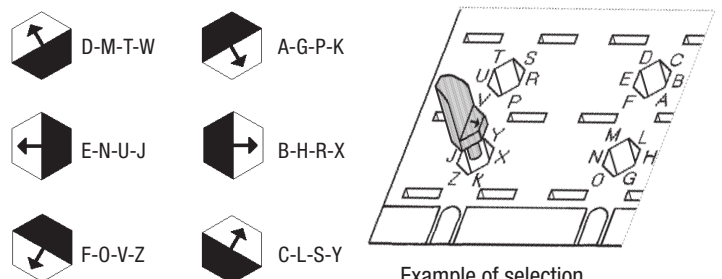

Example of selection, pos. X

4 hexagonal receptacles available on relay and on socket.

Note: all relays are fitted with an anti-rotation guide pin.

# INSTALLATION, OPERATION AND MAINTENANCE

## INSTALLATION

Before installing the relay on a wired socket, disconnect the power supply.

The preferential mounting position is on the wall, with the relay positioned horizontally in the direction of the marking so that the label can be read correctly.

If a relay is used in the “less favorable” conditions including “simultaneously”:

- Power supply: the maximum allowed, permanently
- Ambient temperature: the maximum allowed, permanently
- Current on the contacts: the maximum allowed, permanently
- Number of contacts used: 100 %

It is strongly recommended to space the relays at least 5 mm horizontally and 20 mm vertically to allow for proper upward heat dissipation and increase the life expectancy of the component.

In fact, the relays may be used in less harsh conditions. In this case, the distance between adjacent relays can be reduced or eliminated. Correct interpretation of the conditions of use allows optimization of the available space. Please contact AEMC Instruments for more information.

To increase relay life expectancy, we recommend mounting relays intended for “continuous use” (permanent power supply), alternating them with relays intended for less frequent use.

For safe use, the use of retaining clips is recommended. For use on rolling stock, the relays have been tested according to the EN 61373 standard when equipped with retaining clip(s).

## OPERATION

**Before use:** If the relay is used after long storage periods, for example, contact resistance may increase due to slight natural oxidation or polluting deposits.

In order to restore the optimum conductivity for standard contacts (NOT gold plated), it is recommended to switch a load of at least 110 V<sub>DC</sub> - 100 mA or 24 V<sub>DC</sub> - 500 mA several times. The contacts will thus be “cleaned” by the electric arc generated during the current interruption and the mechanical self-cleaning action.

The common contact rubs against the fixed poles (NO and NC contacts) both when opening and when closing, thus ensuring self-cleaning.

In most cases, a higher contact resistance is not a problem. Many factors contribute to the correct use of the contacts and consequently to the relays’ long-term reliability:

- **Load:** the current switching generates an electric arc with cleaning effects. To ensure proper electrical cleaning and maintain performance levels, we recommend:
  - Standard contacts: Minimum current = 20 mA
  - Gold plated contacts: Minimum current = 10 mA
- **Operating frequency:** relays are components which can operate with a wide range of switching frequencies. High frequency operation also allows a continuous cleaning effect by “sliding” (mechanical cleaning). In the event of low frequency operation (for example few time a day), we advise:
  - Use of contact with currents twice those indicated.
  - For currents lower than 10 mA, use gold plated contacts and connect two contacts in parallel, in order to reduce the equivalent contact resistance

# INSTALLATION, OPERATION AND MAINTENANCE

- **Pollution:** the presence of pollution can cause impurities on the surface of the contacts. Electric charges attract organic molecules and impurities which are deposited on the contact surface. Electrical and mechanical cleaning, respectively, burn off and remove such impurities. In the presence of pollution, the minimum recommended currents must be respected. In extreme cases, provide double the cleaning current.

Condensation is possible inside the relay when energized and the outside ambient temperature is cold; this is quite normal and does not affect the operation of the relay. The plastic materials of the relay do not possess hygroscopic properties.

## MAINTENANCE

No maintenance is required.

In the event of normal relay wear (electrical or mechanical end-of-life), the relay cannot be restored and must be replaced.

To check the component, relay removal must be carried out with slight lateral movements. An “up and down” movement can cause damage the terminals. For RMMV11 / RMMV17 removal, please read the product instructions.

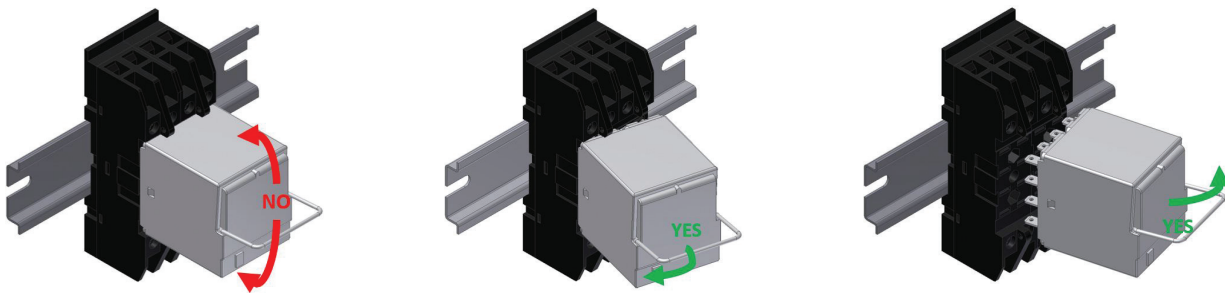

Malfunctions are often caused by a power supply with inverted polarity, by external events or by use with loads exceeding the contact performance.

In case of suspected malfunction, energize the relay and observe if mechanical operation of the contacts / relay mechanism is performed. Check the power supply polarity if relay is equipped with polarized components (example: diode, LED).

- If you plan to use the relay, clean the contacts (see paragraph on “OPERATION”) and check if the circuit load corresponds to the contact specifications. If necessary, replace with relays with gold-plated contacts.  
Note: the electrical continuity of contacts must be checked with adequate current.
- If it does not work, we recommend to use a relay of the same model and configuration.

If an investigation by AEMC Instruments is required, pull out the relay from the socket without removing the cap, avoid any other manipulation, and contact us. You will be asked for the following data: environmental conditions, power supply, switching frequency, contact load, and number of operations performed.

The fault can be described through the “TECHNICAL SUPPORT” section of the website [www.aemc.com/support/technical-support.cfm](http://www.aemc.com/support/technical-support.cfm). The relay cannot be repaired by the user under any circumstances.

## STORAGE

The storage conditions must guarantee the environmental conditions (temperature, humidity and pollution) required for product conservation in order to avoid deterioration.

The product must be stored in an environment which is sheltered from atmospheric agents and pollution-free, with an ambient temperature between (-40 to 185) °F (-40 to 85) °C and 80 % RH maximum Humidity may reach peaks of 95 %. Whatever the case, there must be no condensation. Before use, please read the “OPERATION” section carefully.







*Electrical Test & Measurement Family of Products*

**UNITED STATES & CANADA**

**Chauvin Arnoux<sup>®</sup>, Inc.**  
**d.b.a. AEMC<sup>®</sup> Instruments**  
15 Faraday Drive  
Dover, NH 03820 USA  
(603) 749-6434

**Customer Support**  
Place orders, obtain prices  
and delivery options  
(800) 343-1391  
[customerservice@aemc.com](mailto:customerservice@aemc.com)

**Sales & Marketing Department**  
[sales@aemc.com](mailto:sales@aemc.com)  
[marketing@aemc.com](mailto:marketing@aemc.com)

**Repair & Calibration Service**  
[repair@aemc.com](mailto:repair@aemc.com)

**Technical & Product  
Application Support**  
(800) 343-1391  
[techsupport@aemc.com](mailto:techsupport@aemc.com)

**INTERNATIONAL SUPPORT**

**South America,  
Central America,  
Mexico & the Caribbean,  
Australia & New Zealand**

**Chauvin Arnoux<sup>®</sup>, Inc.**  
**d.b.a. AEMC<sup>®</sup> Instruments**  
15 Faraday Drive  
Dover, NH 03820 USA  
[export@aemc.com](mailto:export@aemc.com)

**All other countries**

**Chauvin Arnoux<sup>®</sup>**  
12-16 Rue Sarah Bernhardt  
92600 Asnières-Sur-Seine, FR  
+1 33 1 44 85 45 85  
[info@chauvin-arnoux.com](mailto:info@chauvin-arnoux.com)  
[www.chauvin-arnoux.com](http://www.chauvin-arnoux.com)

Your authorized AEMC<sup>®</sup> Instruments distributor is:

**Measure Up**  
**WITH AEMC INSTRUMENTS<sup>®</sup>**

To learn more, visit [www.aemc.com](http://www.aemc.com)

Call the Technical Assistance Hotline: (800) 343-1391