

POSITIVE MECHANICAL KEYING

POSITIVE MECHANICAL KEYING

POSITIVE MECHANICAL KEYING

POSITIVE MECHANICAL KEYING

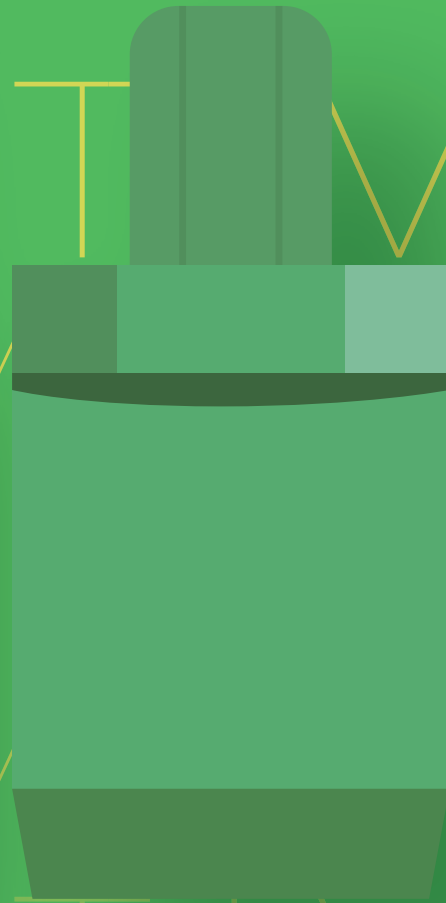

KEYING PINS

INSTANTANEOUS
MONOSTABLE

INSTANTANEOUS
MONOSTABLE WITH
FORCIBLY GUIDED CONTACTS

TIME DELAY
(ON PICK-UP
OR DROP-OUT)

EXPLANATION OF
SOCKET NUMBERING

FRONT
CONNECTION



BACK
CONNECTION

PCB MOUNT

RETAINING CLIPS

KEYING PINS

POSITIVE MECHANICAL KEYING (POLARIZING PINS)

Relay line	Ordering code	
OK, POK, RV	59	
Rxx	VC1705	

Keying pins are mechanical components of semi-hexagonal shape, designed to prevent a given relay from being plugged into a socket intended for a different component. The keying configuration is determined by fitting the pins both to the relay and to the socket, in positions identified by a dedicated code.

The hexagonal geometry of the receptacle allows the polarizing pins to be inserted in six different positions.

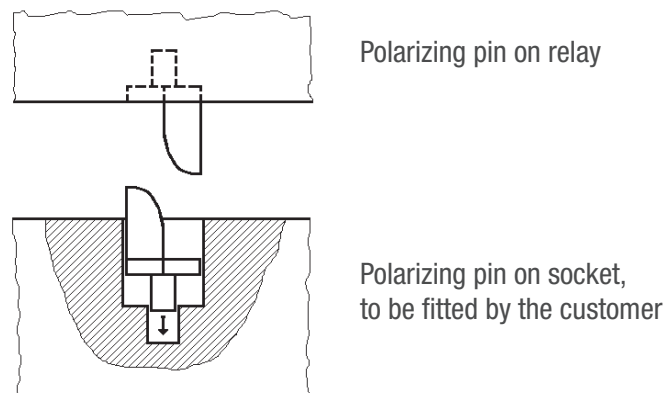

Whilst the use of this component is optional, it is nonetheless strongly recommended where there are multiple relays installed on an electrical panel, for example:

- two or more relays of the same model but with different input voltages
- two or more timer relays with different response and/or logic operating times (e.g. timed to operate on pick-up and timed to operate on drop-out)
- two or more instantaneous relays of different type (e.g. monostable and bistable)

In these cases, the adoption of keying position accessories will prevent any accidental inversion of the relays by the operator, which would risk damage to the system and to the components themselves, as well as jeopardizing safety.

FITMENT AND POSITION

Relays of standard design are not equipped with these accessories.

The mounting position of polarizing pins, if requested, is determined by the manufacturer.

Keying pins for sockets are fitted normally by the customer.

In this case, keying accessories for application to the socket are ordered separately.

The following relays are supplied with pins fitted in positions determined by the manufacturer:

- STATIONS series, approved by ENEL / TERNA Italia to LV15/LV16/20 specifications
- RAILWAYS - FIXED EQUIPMENT series, approved by RFI (FS Italia Group) to RFI DPRIM STF IFS TE 143 A specification
- RAILWAYS - ROLLING STOCK series

POSITIONS OBTAINABLE IN HEXAGONAL RECEPTACLES

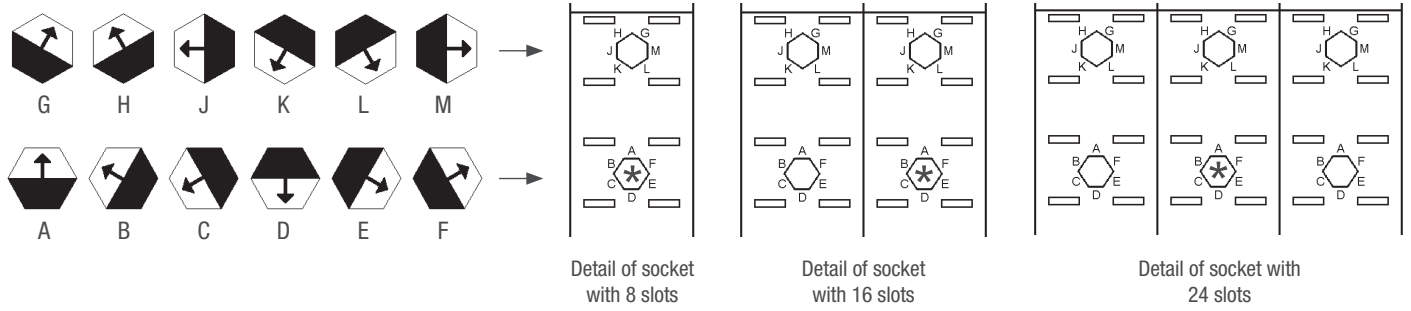

*: receptacle to be left free in the event that the relay is fitted with an anti-rotation pin.

In the case of polarized input (e.g. with flyback diode), the relay is fitted with an anti-rotation pin (diagram below).

The anti-rotation pin is always fitted to the following relays:

POK, BIPOK, TRIPOK, QUADRIPOK, ESAPOK.

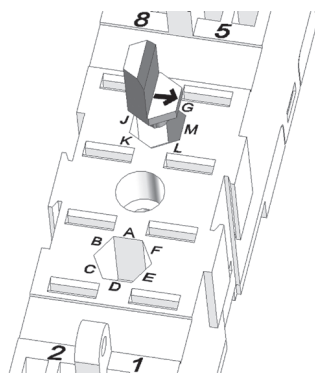

Example of selection, pos. M on socket with 8 slots

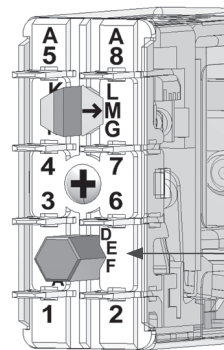

Example of selection, pos. M on POK relay

Anti-rotation pin

C line

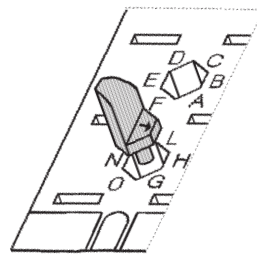
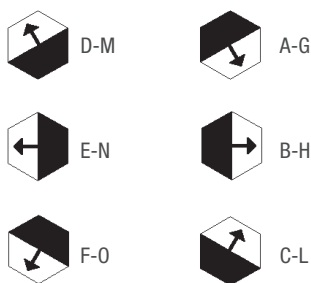

Example of selection, pos. H

2 hexagonal receptacles available on relay and on socket.

D line

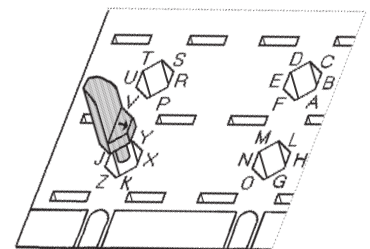
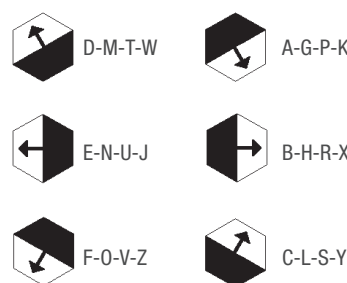

Example of selection, pos. X

4 hexagonal receptacles available on relay and on socket.

Note: all relays are fitted with an anti-rotation guide pin.

INSTALLATION, OPERATION AND MAINTENANCE

INSTALLATION

Before installing the relay on a wired socket, disconnect the power supply.

The preferential mounting position is on the wall, with the relay positioned horizontally in the direction of the marking so that the label can be read correctly.

If a relay is used in the “less favorable” conditions including “simultaneously”:

- Power supply: the maximum allowed, permanently
- Ambient temperature: the maximum allowed, permanently
- Current on the contacts: the maximum allowed, permanently
- Number of contacts used: 100 %

It is strongly recommended to space the relays at least 5 mm horizontally and 20 mm vertically to allow for proper upward heat dissipation and increase the life expectancy of the component.

In fact, the relays may be used in less harsh conditions. In this case, the distance between adjacent relays can be reduced or eliminated. Correct interpretation of the conditions of use allows optimization of the available space. Please contact AEMC Instruments for more information.

To increase relay life expectancy, we recommend mounting relays intended for “continuous use” (permanent power supply), alternating them with relays intended for less frequent use.

For safe use, the use of retaining clips is recommended. For use on rolling stock, the relays have been tested according to the EN 61373 standard when equipped with retaining clip(s).

OPERATION

Before use: If the relay is used after long storage periods, for example, contact resistance may increase due to slight natural oxidation or polluting deposits.

In order to restore the optimum conductivity for standard contacts (NOT gold plated), it is recommended to switch a load of at least 110 V_{DC} - 100 mA or 24 V_{DC} - 500 mA several times. The contacts will thus be “cleaned” by the electric arc generated during the current interruption and the mechanical self-cleaning action.

The common contact rubs against the fixed poles (NO and NC contacts) both when opening and when closing, thus ensuring self-cleaning.

In most cases, a higher contact resistance is not a problem. Many factors contribute to the correct use of the contacts and consequently to the relays’ long-term reliability:

- **Load:** the current switching generates an electric arc with cleaning effects. To ensure proper electrical cleaning and maintain performance levels, we recommend:
 - Standard contacts: Minimum current = 20 mA
 - Gold plated contacts: Minimum current = 10 mA
- **Operating frequency:** relays are components which can operate with a wide range of switching frequencies. High frequency operation also allows a continuous cleaning effect by “sliding” (mechanical cleaning). In the event of low frequency operation (for example few time a day), we advise:
 - Use of contact with currents twice those indicated.
 - For currents lower than 10 mA, use gold plated contacts and connect two contacts in parallel, in order to reduce the equivalent contact resistance

INSTALLATION, OPERATION AND MAINTENANCE

- **Pollution:** the presence of pollution can cause impurities on the surface of the contacts. Electric charges attract organic molecules and impurities which are deposited on the contact surface. Electrical and mechanical cleaning, respectively, burn off and remove such impurities. In the presence of pollution, the minimum recommended currents must be respected. In extreme cases, provide double the cleaning current.

Condensation is possible inside the relay when energized and the outside ambient temperature is cold; this is quite normal and does not affect the operation of the relay. The plastic materials of the relay do not possess hygroscopic properties.

MAINTENANCE

No maintenance is required.

In the event of normal relay wear (electrical or mechanical end-of-life), the relay cannot be restored and must be replaced.

To check the component, relay removal must be carried out with slight lateral movements. An “up and down” movement can cause damage the terminals. For RMMV11 / RMMV17 removal, please read the product instructions.

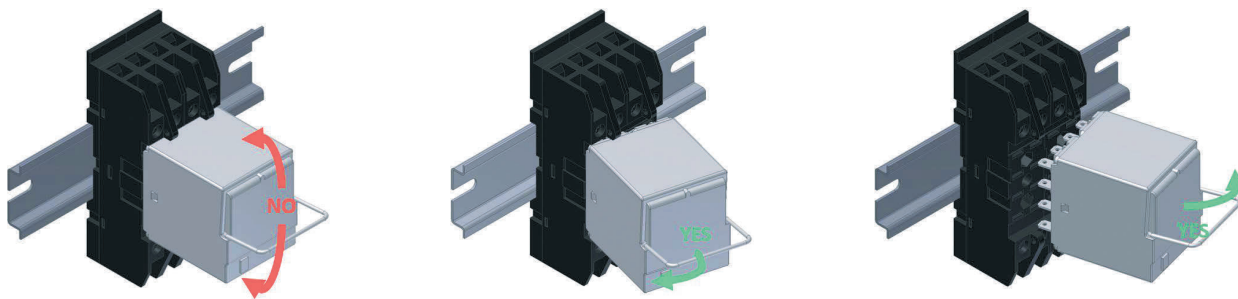

Malfunctions are often caused by a power supply with inverted polarity, by external events or by use with loads exceeding the contact performance.

In case of suspected malfunction, energize the relay and observe if mechanical operation of the contacts / relay mechanism is performed. Check the power supply polarity if relay is equipped with polarized components (example: diode, LED).

- If you plan to use the relay, clean the contacts (see paragraph on “OPERATION”) and check if the circuit load corresponds to the contact specifications. If necessary, replace with relays with gold-plated contacts.
Note: the electrical continuity of contacts must be checked with adequate current.
- If it does not work, we recommend to use a relay of the same model and configuration.

If an investigation by AEMC Instruments is required, pull out the relay from the socket without removing the cap, avoid any other manipulation, and contact us. You will be asked for the following data: environmental conditions, power supply, switching frequency, contact load, and number of operations performed.

The fault can be described through the “TECHNICAL SUPPORT” section of the website www.aemc.com/support/technical-support.cfm. The relay cannot be repaired by the user under any circumstances.

STORAGE

The storage conditions must guarantee the environmental conditions (temperature, humidity and pollution) required for product conservation in order to avoid deterioration.

The product must be stored in an environment which is sheltered from atmospheric agents and pollution-free, with an ambient temperature between (-40 to 185) °F (-40 to 85) °C and 80 % RH maximum Humidity may reach peaks of 95 %. Whatever the case, there must be no condensation. Before use, please read the “OPERATION” section carefully.