

# AC Current Probe

## Model JM500/1000/1500/5A

### User Manual

---

#### DESCRIPTION

The Current Probe (Catalog # 2117.15) is designed for use in industrial environments. The “squared” jaws permit multiple conductor or bus bar positioning. The current output makes it the perfect tool for measurement with DMMs, recorders, power and harmonic meters. This AC Current Probe offers a 10 ft. lead with safety 4mm banana plug.

#### WARNING

These safety warnings are provided to ensure the safety of personnel and proper operation of the instrument.

- Read the instruction manual completely and follow all the safety information before attempting to use or service this instrument.
- Use caution on any circuit: Potentially high voltages and currents may be present and may pose a shock hazard.
- Read the Safety Specifications section prior to using the current probe. Never exceed the maximum voltage ratings given.
- Safety is the responsibility of the operator.
- ALWAYS connect the current probe to the display device before clamping the probe onto the sample being tested.
- ALWAYS inspect the instrument, probe, probe cable, and output terminals prior to use. Replace any defective parts immediately.
- NEVER use the current probe on electrical conductors rated above 600 V in overvoltage category III (CAT III). Use extreme caution when clamping around bare conductors or bus bars.

#### INTERNATIONAL ELECTRICAL SYMBOLS



This symbol signifies that the current probe is protected by double or reinforced insulation. Use only specified replacement parts when servicing the instrument.



This symbol signifies CAUTION! and requests that the user refer to the user manual before using the instrument.

#### RECEIVING YOUR SHIPMENT

Upon receiving your shipment, make sure that the contents are consistent with the packing list. Notify your distributor of any missing items. If the equipment appears to be damaged, file a claim immediately with the carrier and notify your distributor at once, giving a detailed description of any damage.

#### PACKAGING

The AC Current Probe is shipped with this instruction manual and a product warranty and registration card. You can now register on line at [www.aemc.com](http://www.aemc.com)

#### INSTRUMENT COMPATIBILITY

This AC Current Probe is compatible with any AC Ammeter, multimeter, or other current measuring instrument with an input impedance lower than  $.2\Omega$ . To achieve the stated accuracy, use it with an Ammeter having an accuracy of 0.75%.

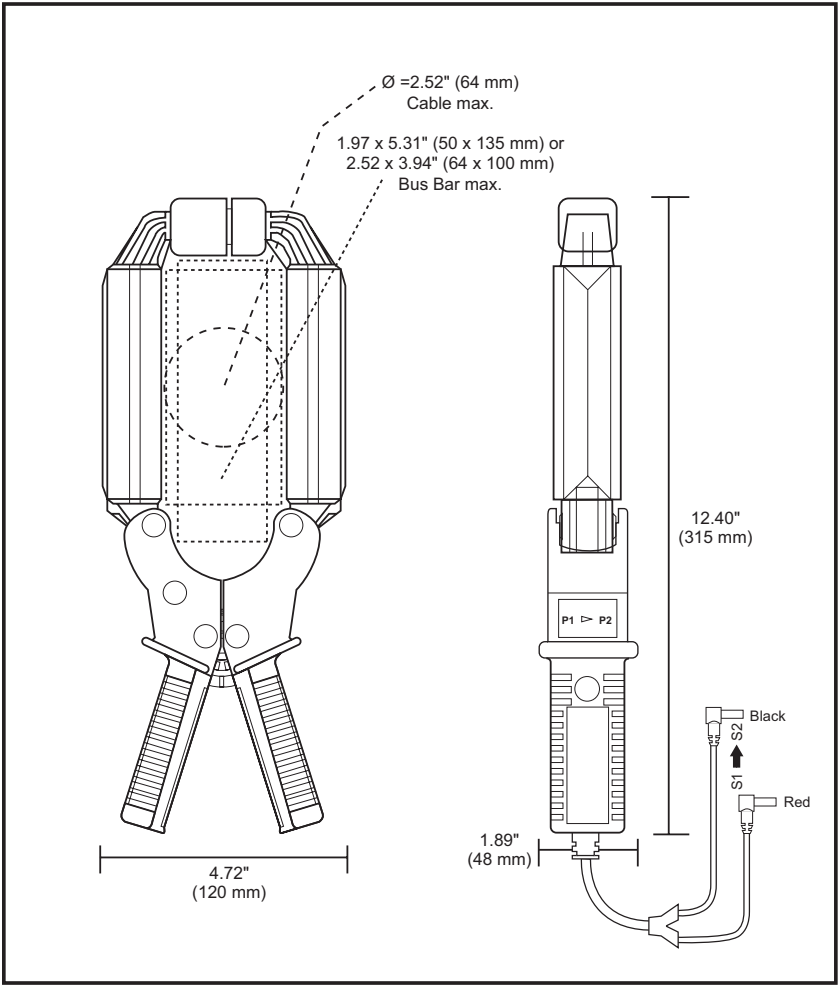

## ELECTRICAL SPECIFICATIONS

### **Current Range:**

1 to 500A AC continuous cycle  
 1 to 1000A AC continuous cycle  
 1 to 1500A AC continuous cycle

### **Transformation Ratio:**

500:5, 1000:5, 1500:5

### **Output Signal:**

10 mA AC/A AC (5A at 500A)  
 5 mA AC/A AC (5A at 1000A)  
 3.33 mA AC/A AC (5A at 1500A)

### **Accuracy and Phase Shift\*:**

#### **500A RANGE**

Primary current	25A	100A	500A
Accuracy %	5%	3%	3%
Phase shift	6°	4°	4°

**Load Impedance:** 0.2  $\Omega$

**Overload:** 700A for 10 mn

**Ampere Second Product:** 3.5 A.s

**Accuracy:** Per IEC 185-26-27  
 Class 0.5 (5 VA) from 48 to 1000 Hz

## 1000A RANGE

Primary current	50A	200A	1000A
Accuracy %	3%	1.5%	1%
Phase shift	3°	1.5°	1°

**Load Impedance:** 0.1  $\Omega$

**Overload:** 1400A for 10 mn

**Ampere Second Product:** 18 A.s

**Accuracy:** Per IEC 185-26-27  
Class 0.5 (5 VA) from 48 to 1000 Hz

## 1500A RANGE

Primary current	75A	300A	1500A
Accuracy %	1.5%	0.75%	0.5%
Phase shift	1.5°	0.75°	0.5°

**Load Impedance:** 0.1  $\Omega$

**Overload:** 1800A for 10 mn

**Ampere Second Product:** 40 A.s

**Accuracy:** Per IEC 185-26-27  
Class 0.5 (5 VA) from 48 to 1000 Hz

(\*Reference conditions: 23°C±3°K, 20 to 85% RH, 45 to 65 Hz, external magnetic field < 40 A/m, no DC component, no external current carrying conductor, test sample centered.)

**Frequency Range:** 30 to 1500 Hz; current derating above 1500Hz for continuous use

**Load Impedance:**  $\leq 1\Omega$  max.

**Working Voltage:**  
600V AC

**Common Mode Voltage:**  
600V AC

**Influence of Adjacent Conductor:**  
< 0.005A/A AC

**Influence of Conductor in Jaw Opening:**  
1.5%  $\pm$  0.2A on 500:1 range  
1%  $\pm$  0.2A on 1000:1 range  
1%  $\pm$  0.2A on 1500:1 range

## MECHANICAL SPECIFICATIONS

**Operating Temp.:** 14° to 122°F (-10° to 50°C)

**Storage Temp.:** -13° to 176°F (-25° to 80°C)

**Influence of Temperature:** < 0.1% per 10°K

**Jaw Opening:** 3.54" (90 mm)

**Maximum Conductor Size:**

Cable: 2.52"  $\varnothing$  max. (64mm)  
Bus bar: 1.97 x 5.31" (50 x 135 mm)  
2.52 x 3.94" (64 x 100 mm)

**Envelope Protection:** IP 20 (IEC 529)

**Drop Test:** 1 m (IEC 68-2-32)

**Mechanical Shock:** 100 g (IEC 68-2-27)

**Vibration:** 10/55/10 Hz, 0.15 mm (IEC 68-2-6)

**Polycarbonate Material:**

Handles: 10% fiberglass charged polycarbonate UL 94 V0

Jaws: ABS UL 94 V2

**Dimensions:**

4.72 x 12.40 x 1.89" (120 x 315 x 48 mm)

**Weight:**  
2.65 lbs. (1200 g)

**Colors:**  
Dark gray handles with red jaws

**Output:**  
10 ft. lead with safety 4mm banana plug

## SAFETY SPECIFICATIONS



**Electrical:**

Double insulation or reinforced insulation between the primary or secondary and the outer case of the handle upon IEC 1010.

**Common Mode Voltage:**  
- 600 V Category III, Pollution Degree 2

**Electromagnetic Compatibility:**  
EN 50081-1 Class B  
EN 50082-2 Electrostatic discharge IEC 1000-4-2  
Radiated field IEC 1000-4-3  
Fast transients IEC 1000-4-4  
Magnetic field at 50/60 Hz IEC 1000-4-8

## ORDERING INFORMATION

**Model JM500/1000/1500/5A..... Cat #2117.15**

## OPERATION

Please make sure that you have already read and fully understand the WARNING section on page 1.

### Making Measurements with the AC Current Probe

- Connect the black and red leads to the Ampere AC range of your DMM or current measuring instrument. Select the appropriate current range (10A AC). Clamp the probe around the conductor to be tested. If the reading is less than 500mA, select the lower range until you obtain the best resolution. Read the value display on the DMM and multiply it by the probe ratio (1000/5). (If reading = 1.59A AC, the current flowing through the probe is  $1.59A \times 200 = 318A$  AC)
- For best accuracy: carefully center the conductor inside the probe jaw, avoid if possible, the proximity of other conductors which may create noise.

### Tips for Making Precise Measurements

- When using a current probe with a meter, it is important to select the range that provides the best resolution. Failure to do this may result in measurement errors.
- Make sure that probe jaw mating surfaces are free of dust and contamination. Contaminants cause air gaps between the jaws, increasing the phase shift between primary and secondary. It is very critical for power measurement.

### MAINTENANCE:



#### Warning

- For maintenance use only original replacement parts.
- To avoid electrical shock, do not attempt to perform any servicing unless you are qualified to do so.
- To avoid electrical shock and/or damage to the instrument, do not get water or other foreign agents into the probe.

### Maintenance

To ensure optimum performance, it is important to keep the probe jaw mating surfaces clean at all times. Failure to do so may result in error in readings. The following is the recommended procedure for cleaning the probe jaws: Use a very fine sand paper (fine 600) to avoid scratching the jaw, then gently clean with a soft, oil cloth.

## REPAIR AND CALIBRATION

You must contact our Service Center for a Customer Service Authorization number (CSA#). This will ensure that when your instrument arrives, it will be tracked and processed promptly. Please write the CSA# on the outside of the shipping container. If the instrument is returned for calibration, we need to know if you want a standard calibration, or a calibration traceable to N.I.S.T. (includes calibration certificate plus recorded calibration data).

Chauvin Arnoux<sup>®</sup>, Inc. d.b.a. AEMC<sup>®</sup> Instruments  
15 Faraday Drive • Dover, NH 03820 USA  
Tel: (800) 945-2362 (Ext. 360)  
(603) 749-6434 (Ext. 360)  
Fax: (603) 742-2346 or (603) 749-6309  
repair@aemc.com

(Or contact your authorized distributor)

Costs for repair, standard calibration, and calibration traceable to N.I.S.T. are available.

**NOTE: All customers must obtain a CSA# before returning any instrument.**

## TECHNICAL AND SALES ASSISTANCE

If you are experiencing any technical problems, or require any assistance with the proper use or application of this instrument, please call our technical hotline:

(800) 343-1391 • (508) 698-2115 • Fax (508) 698-2118

Chauvin Arnoux<sup>®</sup>, Inc. d.b.a. AEMC<sup>®</sup> Instruments  
techsupport@aemc.com  
www.aemc.com