

AC Current Probe

Model JM830A

User Manual

DESCRIPTION

The JM830A (Catalog #2110.83) is designed for use in industrial environments. The “squared” jaws permit multiple conductor or bus bar positioning. The current output makes it the perfect tool for measurement with DMMs, recorders, power and harmonic meters. The Model JM830A is compatible with any AC ammeter, multimeter, or other current measuring instruments with an input impedance lower than 5Ω. To achieve the stated accuracy, use the JM830A with a DMM having an accuracy of 0.75%.

WARNING

These safety warnings are provided to ensure the safety of personnel and proper operation of the instrument.

- Read the instruction manual completely and follow all the safety information before attempting to use or service this instrument.
- Use caution on any circuit: Potentially high voltages and currents may be present and may pose a shock hazard.
- Read the Safety Specifications section prior to using the current probe. Never exceed the maximum voltage ratings given.
- Safety is the responsibility of the operator.
- **ALWAYS** connect the current probe to the display device before clamping the probe onto the sample being tested.
- **ALWAYS** inspect the instrument, probe, probe cable, and output terminals prior to use. Replace any defective parts immediately.
- **NEVER** use the current probe on electrical conductors rated above 600V in overvoltage Category III (CAT III). Use extreme caution when clamping around bare conductors or bus bars.

INTERNATIONAL ELECTRICAL SYMBOLS



This symbol signifies that the current probe is protected by double or reinforced insulation. Use only factory specified replacement parts when servicing the instrument.



This symbol signifies CAUTION! and requests that the user refer to the user manual before using the instrument.



This is a type A current sensor. This symbol signifies that application around and removal from HAZARDOUS LIVE conductors is permitted.

DEFINITION OF MEASUREMENT CATEGORIES

Cat. II: For measurements performed on circuits directly connected to the electrical distribution system.

Examples are measurements on household appliances or portable tools.

Cat. III: For measurements performed in the building installation at the distribution level such as on hardwired equipment in fixed installation and circuit breakers.

Cat. IV: For measurements performed at the primary electrical supply (<1000V) such as on primary overcurrent protection devices, ripple control units, or meters.

RECEIVING YOUR SHIPMENT

Upon receiving your shipment, make sure that the contents are consistent with the packing list. Notify your distributor of any missing items. If the equipment appears to be damaged, file a claim immediately with the carrier and notify your distributor at once, giving a detailed description of any damage.

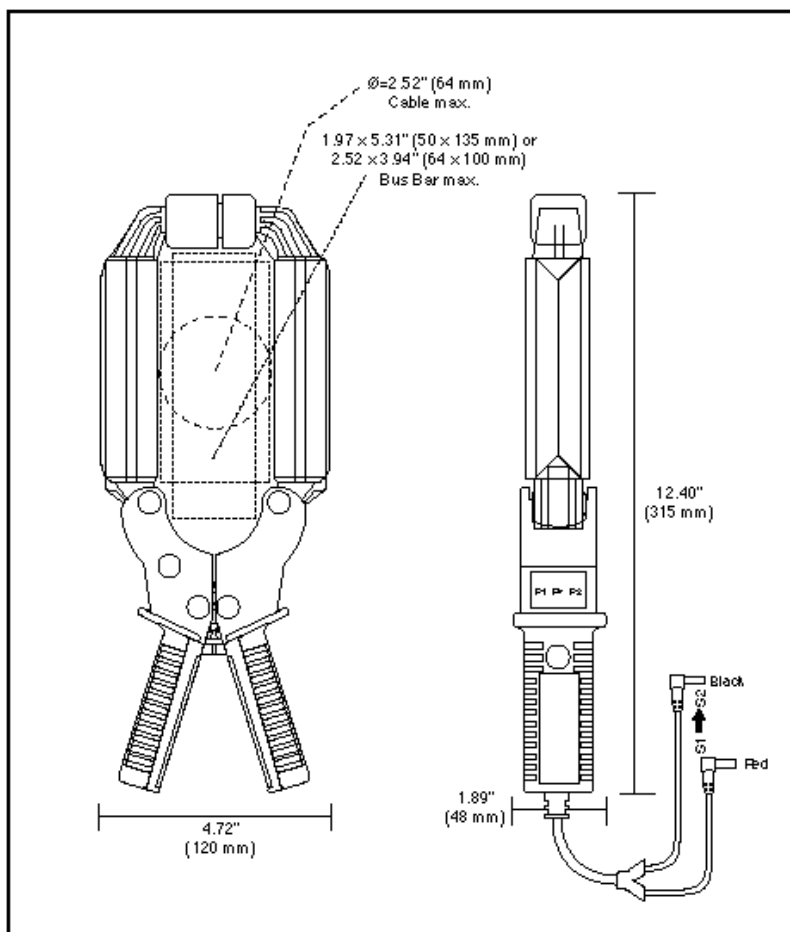

ELECTRICAL SPECIFICATIONS

Current Range:

1 to 2400A AC, continuous cycle for the full temperature range (3000A if temperature < 35°C or 95°F)

Transformation Ratio:

3000:1

Output Signal:

0.333mA AC/A AC (1A at 3000A)

Accuracy and Phase Shift*:

Primary current	150A	600A	3000A
Accuracy %	1.5%	0.75%	0.5%
Phase shift	1.5°	0.75°	0.5°

(*Reference conditions: 23°C \pm 3°K, 20 to 85% RH, 48 to 65 Hz, external magnetic field < 40 A/m, no DC component, no external current carrying conductor, test sample centered.) Load impedance 5 Ω .

Overload: 3600A during 5 mn

Open Circuit Voltage:

< 46V by limiting circuit

Accuracy: Per IEC 185-26-27

Class 0.5 from 48 to 1000 Hz

Frequency Range:

30 Hz to 5 kHz; current derating above 1 kHz for continuous use

Ampere Second Product: 90 AA

Load Impedance: $\leq 5\Omega$

Working Voltage: 600V AC

Common Mode Voltage: 600V AC

Influence of Adjacent Conductor:

0.005A/A AC

Influence of Conductor in Jaw Opening:

1% \pm 0.1A of reading

MECHANICAL SPECIFICATIONS

Operating Temperature:

14° to 122°F (-10° to 50°C)

Storage Temperature:

-13° to 176°F (-25° to 80°C)

Influence of Temperature:

< 0.1% per 10°K

Jaw Opening: 3.54" (90mm)

Maximum Conductor Size:

Cable: 2.52" \varnothing max. (64mm)

Bus bar: 1.97 x 5.31" (50 x 135mm)

2.52 x 3.94" (64 x 100mm)

Envelope Protection:

IP 20 (IEC 529)

Drop Test:

500mm (IEC 68-2-32)

Mechanical Shock:

100g (IEC 68-2-27)

Vibration:

10/55/10Hz, 0.15mm (IEC 68-2-6)

Polycarbonate Material:

Handles: 10% fiberglass charged polycarbonate UL 94 V0

Jaws: ABS UL 94 V2

Dimensions:

4.72 x 12.40 x 1.89" (120 x 315 x 48 mm)

Weight:

2.65 lbs. (1200 g)

Colors:

Dark gray handles with red jaws

Output:

5 ft. (1.5m) lead with safety 4mm banana plug

SAFETY SPECIFICATIONS



Electrical Conformity to International Standards:

This instrument is compliant with IEC 61010-2-032, 300V category IV and 600V category III.

Double or reinforced insulation .

Type of current sensor per IEC 61010-2-032:

type A .

Electromagnetic Compatibility:

The device is in conformity with standard IEC 61326-1.

ORDERING INFORMATION

Current Probe JM830A Cat #2110.83

Includes a user manual and a product warranty and registration card

Accessories:

Banana plug adapter

(to non-recessed plug) **Cat #1017.45**

OPERATION

Please make sure that you have already read and fully understand the WARNING section on page 1.

Making Measurements with the AC Current Probe Model JM830A

- Connect the black and red terminals to the Ampere AC range of your DMM or current measuring instrument. Select the appropriate current range (2A AC). Clamp the probe around the conductor to be tested. If the reading is less than 200mA, select the lower range until you obtain the best resolution. Read the value display on the DMM and multiply it by the probe ratio (3000/1 = 3000). (If reading = 0.592A AC, the current flowing through the probe is 0.592A x 3000 = 1776A).
- For best accuracy: carefully center the conductor inside the probe jaw, avoid if possible, the proximity of other conductors which may create noise.

Tips for Making Precise Measurements

- When using a current probe with a meter, it is important to select the range that provides the best resolution. Failure to do this may result in measurement errors.
- Make sure that probe jaw mating surfaces are free of dust and contamination. Contaminants cause air gaps between the jaws, increasing the phase shift between primary and secondary. It is very critical for power measurement.

MAINTENANCE



Warning:

- For maintenance use only original replacement parts.
- To avoid electrical shock, do not attempt to perform any servicing unless you are qualified to do so.
- To avoid electrical shock and/or damage to the instrument, do not get water or other foreign agents into the probe.

Cleaning:

To ensure optimum performance, it is important to keep the probe jaw mating surfaces clean at all times. Failure to do so may result in error in readings. To clean the probe jaws, use very fine sand paper (fine 600) to avoid scratching the jaw, then gently clean with a soft, oil cloth.

REPAIR AND CALIBRATION

You must contact our Service Center for a Customer Service Authorization number (CSA#). This will ensure that when your instrument arrives, it will be tracked and processed promptly. Please write the CSA# on the outside of the shipping container.

Chauvin Arnoux®, Inc. d.b.a. AEMC® Instruments

15 Faraday Drive • Dover, NH 03820 USA

(800) 945-2362 (Ext. 360) • (603) 749-6434 (Ext. 360) • repair@aemc.com

(Or contact your authorized distributor)

NOTE: All customers must obtain a CSA# before returning any instrument.

TECHNICAL AND SALES ASSISTANCE

If you are experiencing any technical problems, or require any assistance with the proper use or application of this instrument, please contact our technical hotline:

(800) 945-2362 (Ext. 351) • (603) 749-6434 (Ext. 351) • techsupport@aemc.com

LIMITED WARRANTY

The current probe is warranted to the owner for a period of two years from the date of original purchase against defects in manufacture. This limited warranty is given by AEMC® Instruments, not by the distributor from whom it was purchased. This warranty is void if the unit has been tampered with, abused or if the defect is related to service not performed by AEMC® Instruments.

Full warranty coverage and product registration is available on our website at: www.aemc.com.

Please print the online Warranty Coverage Information for your records.