

AC/DC CURRENT PROBE MODEL MD510

Catalog No. 1201.11

USER MANUAL

The AEMC AC/DC Current Probe Model 510 is a battery-powered clamp-on current probe that is used with a voltmeter to measure AC or DC currents up to 1000 amps. The jaws clamp around a conductor allowing current measurements without breaking the circuit. A Hall sensor mounted in a gap in the core senses the magnetic field produced by the current being measured. An amplifier circuit generates an output signal of 1 mV per amp. Demagnetizing (degaussing) is accomplished by means of a thumbwheel.

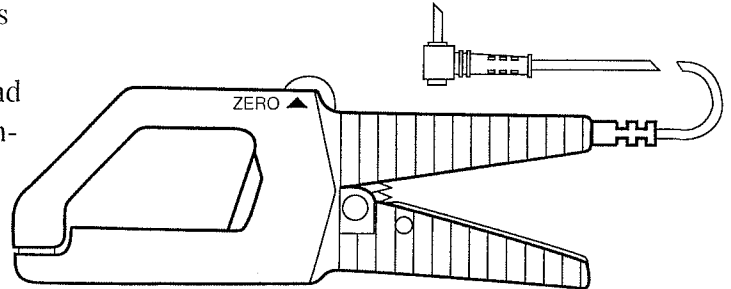

SPECIFICATIONS

Current Range:

1 to 1000 A DC

1 to 700 A AC

Output Signal:

1 mV DC/A DC (1 V DC at 1000 A DC)

1 mV AC/A AC (700 mV AC at 700 A AC)

Accuracy*:

DC: 1 to 100 A: $\pm 2\%$ reading ± 1 A

1 to 700 A: $\pm 3\%$ reading

700 to 1000 A: $\pm 5\%$ reading

AC (48 to 62 Hz)

1 to 100 A: $\pm 2\%$ reading ± 1 A

100 to 700 A: $\pm 3\%$ reading

AC (62 to 440 Hz)

1 to 100 A: $\pm 3\%$ reading ± 1 A

100 to 700 A: 5%

* 64° to 82°F (18° to 28°C), conductor centered, zero adjustment prior to measurement (DC only)

Working Voltage: 660 V max.

Maximum Conductor Sizes:

1 each 1.18" (30 mm) \varnothing

2 each 0.98" (25 mm) \varnothing (2 x 500 MCM)

Load Impedance: >1 M Ω /100 pF

Batteries: Two 1.5 V "AAA"

Life: 260 hrs typical

Consumption: 3.5 mA typical; 4.0 mA maximum

Low Battery Indication: Output voltage is between 0.0 and -99.9 mV with the probe switched off (load impedance >100 k Ω)

Influence of Adjacent Conductor: 0.04 A typical

Influence of Conductor Position in Jaw Opening (for \varnothing 30 mm conductor not aligned): $\pm 1.6\%$

Temperature Coefficient:

± 0.06 x specification per °C (0° to 18°, 28° to 50°)

Operating Temperature: 32° to 122°F (0° to 50°C)

Storage Temperature: -40° to 140°F (-40° to 60°C)

Noise:

DC (0 to 1 Hz): ≤ 0.1 mV RMS

AC (1 Hz to 100 kHz): ≤ 0.3 mV RMS

Relative Humidity:

0 to 90%

(32° to 95°F [0° to 35°C])

0 to 70%

(95° to 122°F [35° to 50°C])

Output: 5 ft (1.5 m) leads with banana plugs

Dimensions: 2.60 x 7.68 x 1.34" (66 x 195 x 34 mm)

Weight: 13 oz (370 g) approx.

Color: Dark gray

Dielectric Test: 4000 V RMS

Safety Standard: IEC 348

U.S. Patents: #DES 288,301 & #4,704,575

MAINTENANCE

Be sure that mating surfaces of the jaw are free of dirt or foreign matter. If they are rusted, gently clean with a soft, oiled cloth.

For further maintenance, calibration, and/or repair, contact our factory service center:

Instrumentation Corporation

Bellamy Industrial Park

Faraday Drive

Dover, NH 03820

(603) 749-6434

AC/DC CURRENT PROBE MODEL MD510

COMPATABILITY

The AC/DC Current Probe Model MD510 is compatible with any voltmeter, multimeter, or other voltage-measuring instrument that has the following features:

- Range and resolution capable of displaying 1 mV of output per amp of measured current.
- Voltmeter accuracy (uncertainty) of 0.75% or better to take full advantage of the accuracy of the probe.
- Input impedance of 1 M Ω , 100 pF or greater.

OPERATION

Warning

- Connect the probe to the DMM or voltage measuring instrument **before** clamping the probe around a conductor. **Never use your probe with defective leads.**
- Never use the probe on circuits rated higher than 660V RMS.
- Never leave the probe clamped around a conductor while not connected to a voltage measuring instrument or DMM.
- Carefully center the conductor inside the probe jaws and ascertain that the probe is perpendicular to the conductor.
- Avoid, if possible, the proximity of other conductors which may create noise.
- Check the magnetic mating surfaces of the probe jaws; these should be free of dirt, rust, or other foreign matter.

Connection / Battery Check

Connect the probe to the multimeter or other instrument. Be sure to observe the polarities: red = positive terminal, black = negative terminal. Select the 200 mV DC range or range allowing measurements up to 200 mV. With the probe switch in the "OFF" position check that the multimeter indicates at least -110 mV. If the reading is below -110 mV (eg. -90 mV, -80 mV, etc.), replace both batteries which are located in the compartment inside the handle. Note: If the battery check is okay, but the probe does not work, invert the batteries and run the check again (see figure 1). To begin measurements, select the appropriate multimeter range; the output signal of the Model MD510 is 1 mV AC/A AC or 1 mV DC/A DC.

Zeroing the Probe:

When the AC/DC Current Probe Model MD510 has been used for a current measurement and then removed from the conductor, a small amount of residual magnetism often remains in the core. This residual magnetism will cause the voltmeter to show a small DC reading even though there is no current passing through the jaws of the probe. The residual magnetism should not cause a problem for AC current measurement because the AC voltage function in

most multimeters is AC coupled; therefore, the DC offset caused by the residual magnetism will contribute to reading errors. The residual magnetism can be minimized by using the thumbwheel to show a reading of 0 (\pm a few counts) on the multimeter (probe not clamped on a conductor).

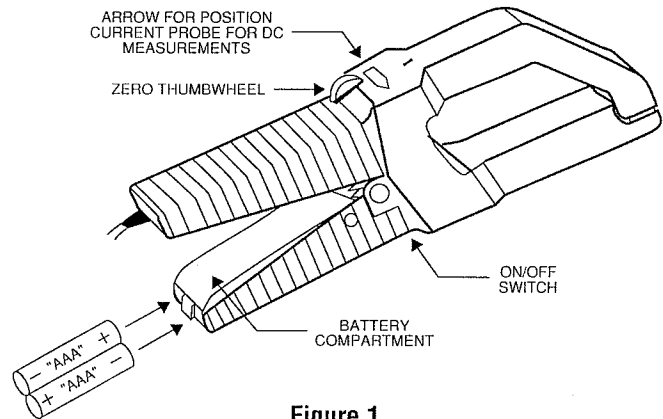

Figure 1

On DC

Connect the probe to the multimeter and select the appropriate DC range: 200 mV DC to measure up to 200 A DC, 2 V DC to measure up to 1000 A DC.

On AC

Connect the probe to the multimeter and select the appropriate AC range: 200 mV AC to measure up to 200 A AC, 2 V AC to measure up to 700 A AC. Zeroing is not needed for AC measurements unless you use the probe to measure AC with a DC component and your multimeter does not filter DC.

Current Measurement

Zero the probe if necessary, and observe the polarities for DC measurement. Select the appropriate range on your multimeter. Clamp the probe on the conductor to be measured and read the current flowing directly on your meter. The output of the probe is 1 mV AC/A AC or 1 mV DC/A DC. If your meter indicates a negative reading during DC measurements, this simply means that the current flow is in the opposite direction of the arrow marked "I" on the probe or that the probe connections are reversed (polarity). After measurement, turn the probe OFF.

Low Current Measurement

When the current to be measured is too low for the probe or better accuracy is sought, it is possible to insert the conductor multiple times through the probe jaws (see figure 2). The value of the current is the ratio of the reading to the number of turns.

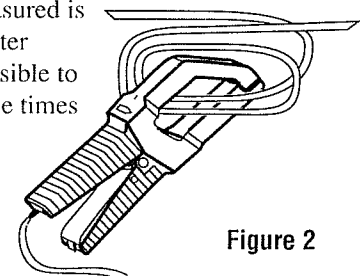
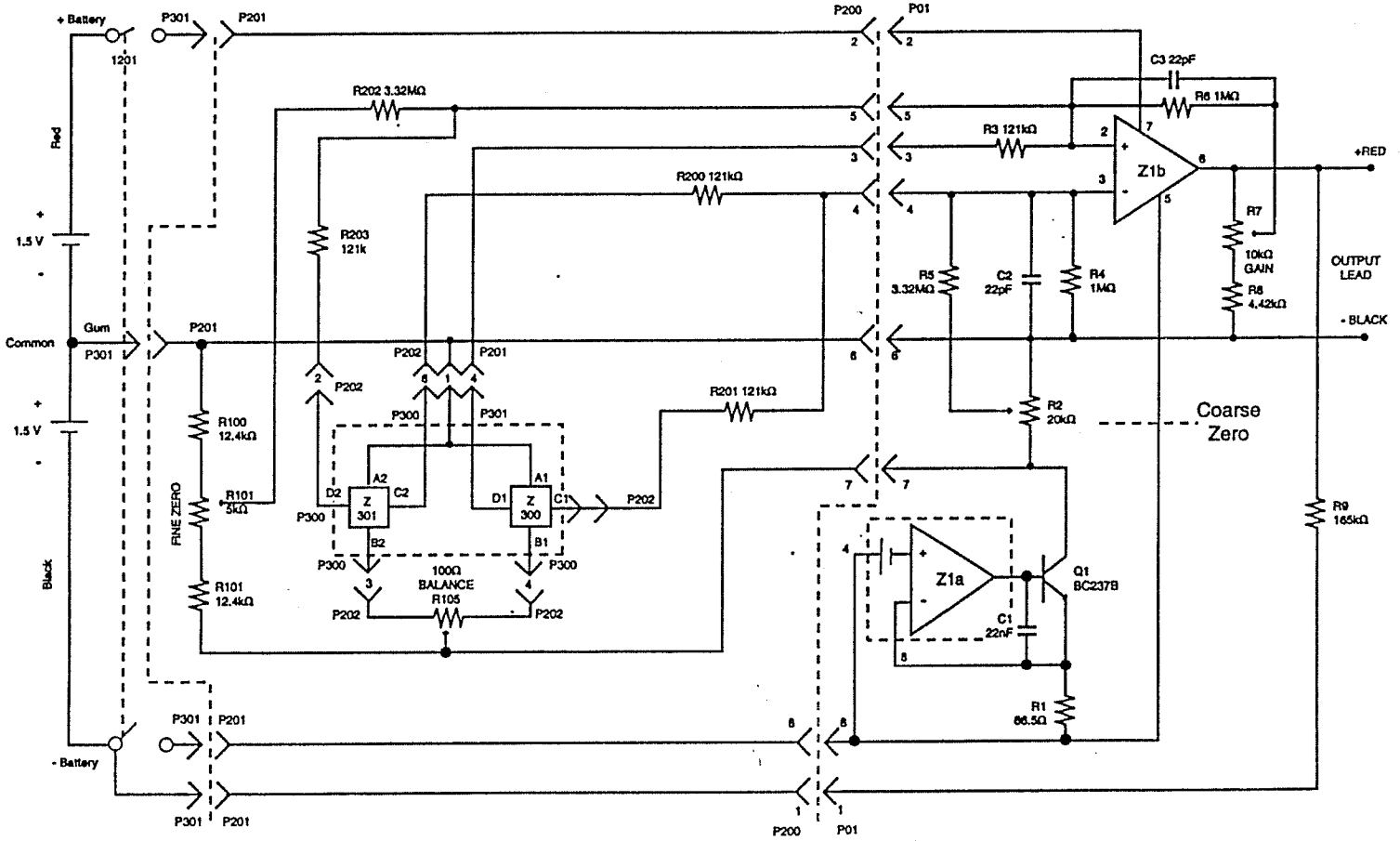

Figure 2

SCHMATIC

P01 → P200
P300 → P202
P301 → P201



REV	DATE
1	