

# AC Current Probe Model MN05

## User Manual

---

### DESCRIPTION

The MN05 (Cat. #2129.19) is small, compact AC current probe. Designed to meet the most stringent demands in industry and electrical contracting, they also meet the latest safety and performance standards. The probe has two measurement ranges (10 and 100Arms) which makes it a perfect tool for measurement with DMMs, recorders. The Model MN05 is compatible with any voltmeter, multimeter, or other current measurement instrument with an input impedance greater than  $1M\Omega$ . To achieve the stated accuracy, use the probe with a voltmeter having an accuracy of 0.75% or better.

### WARNING

These safety warnings are provided to ensure the safety of personnel and proper operation of the instrument.

- Read the instruction manual completely and follow all the safety information before attempting to use or service this instrument.
- Use caution on any circuit: Potentially high voltages and currents may be present and may pose a shock hazard.
- Read the Safety Specifications section prior to using the current probe. Never exceed the maximum voltage ratings given.
- Safety is the responsibility of the operator.
- ALWAYS connect the current probe to the display device before clamping the probe onto the sample being tested.
- ALWAYS inspect the instrument, probe, probe cable, and output terminals prior to use. Replace any defective parts immediately.
- NEVER use the current probe on electrical conductors rated above 600V in overvoltage category III (CAT III). Use extreme caution when clamping around bare conductors or bus bars.

### INTERNATIONAL ELECTRICAL SYMBOLS



This symbol signifies that the current probe is protected by double or reinforced insulation. Use only factory specified replacement parts when servicing the instrument.



This symbol signifies CAUTION! and requests that the user refer to the user manual before using the instrument.



This is a type A current sensor. This symbol signifies that application around and removal from HAZARDOUS LIVE conductors is permitted.

### DEFINITION OF MEASUREMENT CATEGORIES

**CAT II:** For measurements performed on circuits directly connected to the electrical distribution system. Examples are measurements on household appliances or portable tools.

**CAT III:** For measurements performed in the building installation at the distribution level such as on hardwired equipment in fixed installation and circuit breakers.

**CAT IV:** For measurements performed at the primary electrical supply (<1000V) such as on primary overcurrent protection devices, ripple control units, or meters.

### RECEIVING YOUR SHIPMENT:

Upon receiving your shipment, make sure that the contents are consistent with the packing list. Notify your distributor of any missing items. If the equipment appears to be damaged, file a claim immediately with the carrier and notify your distributor at once, giving a detailed description of any damage.

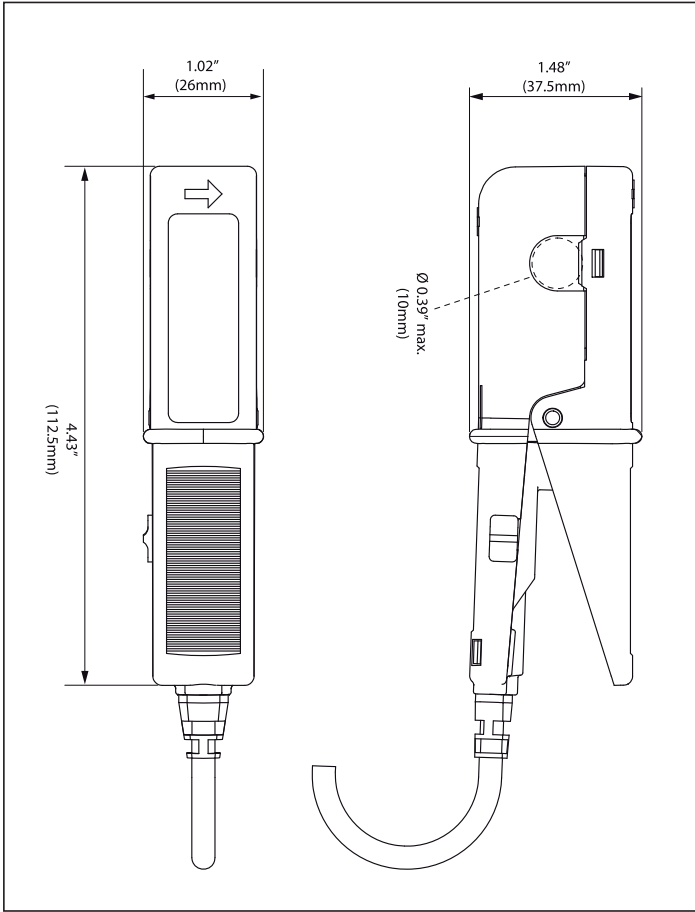

## **ELECTRICAL SPECIFICATIONS**

*\*Reference conditions: 18°C to 28°C, 20 to 75% RH, external magnetic field <40 A/m, 48 to 65 Hz sine wave, distortion factor less than 1%, no DC component, no external current carrying conductor, test sample centered. Load impedance 1M $\Omega$*

**Nominal Range:** 10A, 100A

**Measurement Range:**

10A: 5mA to 10AAC

100A: 1 to 100AAC

**Output Signal:**

10A: 1mVAC/mAAC (10V @ 10A)

100A: 1mVAC/AAC (100mV @ 100A)

**Accuracy and Phase Shift\*:**

10A:  $\leq 3\%$  Reading + 0.15mA

100A:  $\leq 2\%$  Reading + 50mA

Phase Shift: Not Specified

**Overload:**

10A: 15A permanent

100A: 150A permanent

**Frequency Range:** 48 to 500Hz

**Working Voltage:** 600Vrms

**Common Mode Voltage:** 600Vrms

**Influence of Adjacent Conductor:**

< 2mA/A at 50Hz

**Influence of Conductor Position in Jaw:**

0.1% of mV output @ 50/60Hz

**Influence of Frequency:**

10A: < 3% from 65 to 500Hz

100A: < 1% from 65 to 500Hz

**Influence of Temperature:**

≤ 0.2%/10°K

**Influence of Humidity (10 to 90% RH):**

≤ 0.1% of mA

**MECHANICAL SPECIFICATIONS**

**Operating Temperature:**

14° to 122°F (-10° to +50°C)

**Storage Temperature:**

-40° to 176°F (-40° to +80°C)

**Maximum Cable Diameter:**

One Ø 0.39" (10mm)

**Case Protection:**

IP 40 (IEC 529)

**Drop Test:**

Test per IEC 68-2-32:

1.0m drop on 38mm of Oak on concrete

**Mechanical Shock:**

Test per IEC 68-2-27

**Vibration:** Test per IEC 68-2-6

**Dimensions:**

4.43 x 1.48 x 1.02"

(112.5 x 37.5 x 26mm)

**Weight:**

180 g (6.5 oz)

**Polycarbonate Material:**

Jaws: Red Polycarbonate

Case: Dark Polycarbonate

**Opening Operations - Life:**

> 50,000

**Output:**

Double/reinforced insulated 5 ft (1.5m) lead with

safety 4mm banana plug

**Altitude:** <2000 m

**SAFETY SPECIFICATIONS**



Indoor use only

**Electrical:**

Conforms to IEC 1010-2-32. ed. 2 2003

**Common Mode Voltage:**

300V CAT IV, 600V CAT III, Pollution Degree 2

**Electromagnetic Compatibility:**

EN61326-1 (ed. 97)+A1 (ed. 98) : transmission and immunity in an industrial site

**ORDERING INFORMATION**

**AC Current Probe MN05 ..... Cat. #2129.19**

**Accessories:**

Banana plug adapter

(to non-recessed plug) ..... **Cat #1017.45**

## OPERATION

Please make sure that you have already read and fully understand the WARNING section on page 1.

### Making Measurements with the AC Current Probe Model MN05

- Connect the black lead of the current probe to “common” and the red lead to the AC voltage range on your DMM or other voltage measuring instrument. The “10A” range has an output signal of 1mV/mA AC. This means that for 10A AC in a conductor around which the probe is clamped, 10V AC will come out of the probe leads to your DMM or instrument. The “100A” range has an output signal of 1mV/A AC. This means that for 100A AC in a conductor around which the probe is clamped, 100mV AC will come out of the probe leads to your DMM or instrument. Select the range on your DMM or instrument which corresponds best to the measured current. If the current magnitude is unknown, start with the highest range first and work down until the appropriate range and resolution is reached. Clamp the probe around the conductor. Take the reading on the meter and multiply it by the output signal used to obtain the measured current. (e.g. If the meter reads 100.5mV [range 1mV/mA], then current equals 100.5mA AC). Unclamp the probe from the conductor before disconnecting it from your DMM or instrument.
- For best accuracy, avoid if possible, the proximity of other conductors which may create noise.

### Tips for Making Precise Measurements

- When using a current probe with a meter, it is important to select the range that provides the best resolution. Failure to do this may result in measurement errors.
- Make sure that probe jaw mating surfaces are free of dust and contamination. Contaminants cause air gaps between the jaws, increasing the phase shift between primary and secondary. It is very critical for power measurement.

## MAINTENANCE:

### Warning

- For maintenance use only original factory replacement parts.
- To avoid electrical shock, do not attempt to perform any servicing unless you are qualified to do so.
- To avoid electrical shock and/or damage to the instrument, do not get water or other foreign agents into the probe

### Cleaning

To ensure optimum performance, it is important to keep the probe jaw mating surfaces clean at all times. Failure to do so may result in error in readings. To clean the probe jaws, use very fine sand paper (fine 600) to avoid scratching the jaw, then gently clean with a soft oiled cloth.

## REPAIR AND CALIBRATION

You must contact our Service Center for a Customer Service Authorization number (CSA#). This will ensure that when your instrument arrives, it will be tracked and processed promptly. Please write the CSA# on the outside of the shipping container.

Chauvin Arnoux®, Inc. d.b.a. AEMC® Instruments

15 Faraday Drive • Dover, NH 03820 USA

(800) 945-2362 (Ext. 360) • (603) 749-6434 (Ext. 360) • [repair@aemc.com](mailto:repair@aemc.com)

(Or contact your authorized distributor)

**NOTE: All customers must obtain a CSA# before returning any instrument.**

## TECHNICAL AND SALES ASSISTANCE

If you are experiencing any technical problems, or require any assistance with the proper use or application of this instrument, please contact our technical hotline:

(800) 343-1391 • (508) 698-2115 • [techsupport@aemc.com](mailto:techsupport@aemc.com)

## LIMITED WARRANTY

The current probe is warranted to the owner for a period of two years from the date of original purchase against defects in manufacture. This limited warranty is given by AEMC® Instruments, not by the distributor from whom it was purchased. This warranty is void if the unit has been tampered with, abused or if the defect is related to service not performed by AEMC® Instruments.

**Full warranty coverage and product registration is available on our website at: [www.aemc.com/warranty.html](http://www.aemc.com/warranty.html).**

Please print the online Warranty Coverage Information for your records.