

AC Current Probe Models MN250 and MN251

User Manual

DESCRIPTION

The MN250/MN251 (Catalog #2115.76 and #2115.77) are the latest in compact AC Current probes. Designed to meet the most stringent demands in industry and electrical contracting, they also meet the latest safety and performance standards. The probes have a measurement range up to 240 Arms which makes them perfect tools for measurement with DMMs, recorders, power and harmonic meters. The Models MN250/MN251 are compatible with any AC voltmeter, multimeter, or other voltage measurement instrument that is capable of displaying 1mV of output per amp of measured current, Voltmeter accuracy of 0.75% or better and an input impedance of $\geq 1 \text{ M}\Omega$.

WARNING

The safety warnings are provided to ensure the safety of personnel and proper operation of the instrument. Read the instruction completely.

- Use caution on any circuit: potentially high voltages and currents may be present and may pose a shock hazard.
- Do not use the probe if damaged. Always connect the current probe to the measuring device before it is connected around the conductor
- Do not use on non-insulated conductor with a potential to ground greater than 600V CAT III pollution 2. Use extreme caution when clamping around bare conductors or bus bars.
- Before each use, inspect the probe; look for cracks in housing or output cable insulation.
- Do not use clamp in wet environment or in locations that hazardous gases exist.
- Do not use the probe anywhere beyond the tactile barrier.

INTERNATIONAL ELECTRICAL SYMBOLS



This symbol signifies that the current probe is protected by double or reinforced insulation. Use only factory specified replacement parts when servicing the instrument.



This symbol signifies CAUTION! and requests that the user refer to the user manual before using the instrument.



This is a type A current sensor. This symbol signifies that application around and removal from HAZARDOUS LIVE conductors is permitted.

DEFINITION OF MEASUREMENT CATEGORIES

CAT IV: For measurements performed at the primary electrical supply (<1000V) such as on primary overcurrent protection devices, ripple control units, or meters.

CAT III: For measurements performed in the building installation at the distribution level such as on hardwired equipment in fixed installation and circuit breakers.

CAT II: For measurements performed on circuits directly connected to the electrical distribution system. Examples are measurements on household appliances or portable tools.

®

RECEIVING YOUR SHIPMENT

Upon receiving your shipment, make sure that the contents are consistent with the packing list. Notify your distributor of any missing items. If the equipment appears to be damaged, file a claim immediately with the carrier and notify your distributor at once, giving a detailed description of any damage.

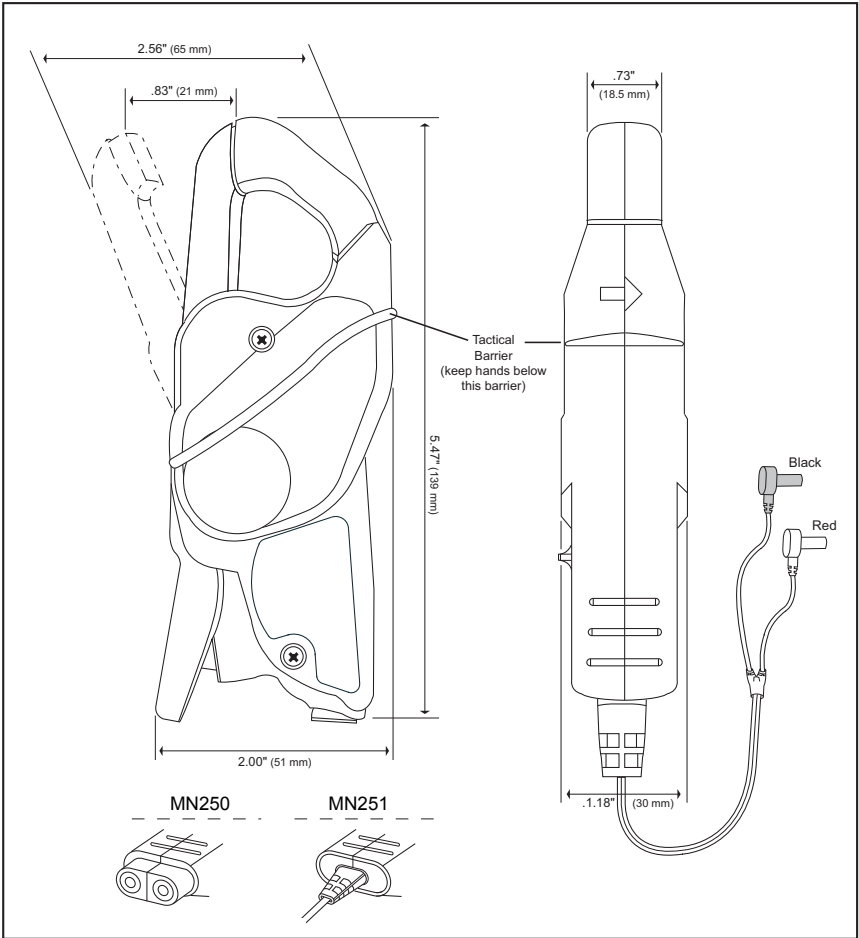

ELECTRICAL SPECIFICATIONS

Nominal Range: 200A

Measurement Range: 0.1 to 240A

Transformation Ratio: Voltage output

Output Signal: 1mV/A

Accuracy and Phase Shift*:

- Accuracy: 0.5 to 10A: 3.0% Reading \pm 0.5mV
- 10 to 40A: 2.5% Reading \pm 0.5mV
- 40 to 100A: 2.0% Reading \pm 0.5mV
- 100 to 240A: 1.0% Reading \pm 0.5mV

- Phase Shift: 0.5 to 10A: Not Specified
- 10 to 40A: \leq 5°
- 40 to 100A: \leq 3°
- 100 to 240A: \leq 2.5°

(*Reference conditions: 18°C to 28°C, 20 to 75% RH, external magnetic field < 40 A/m, 48 to 65 Hz sine wave, distortion factor less than 1%, no DC component, no external current carrying conductor, test sample centered.) Load impedance > 1MΩ.

Frequency Range: 40 to 10kHz

Limit Operating Conditions:

200A permanently to 1kHz
Derating above 3kHz: 200 A x (1/0.333 F), F in kHz

Crest Factor:

3 @ 200Arms with an error (due to CF) of 3%

Working Voltage: 600Vrms

Common Mode Voltage: 600Vrms

Influence of Adjacent Conductor:
< 15mA/A at 50Hz

Influence of DC on AC signal:
DC Current < 20A, < 5%

Influence of Conductor Position in Jaw:
0.5% of mV output @ 50/60Hz

Influence of Frequency:
40Hz to 1kHz: 3% of mV output
1kHz to 10kHz: 12% of mV output

Influence of Load:
< 3% of mA output from 40Hz to 1kHz
< 12% of mA output from 1kHz to 10kHz

Influence of Temperature:
≤ 150 ppm/°K, or 0.15% of mV output per 10°K

Influence of Humidity (10 - 90% RH):
≤ 0.2% of mV output per 10°K @ 18°C to 28°C

MECHANICAL SPECIFICATIONS

Operating Temperature:
14° to 131°F (-10° to +55°C)

Storage Temperature:
-40° to 158°F (-40° to +70°C)

Operating Relative Humidity:
10° to 35°C 85% RH (without roll-off above 35°C)

Maximum Cable Diameter:
One Ø 0.78" (20 mm), bus bar 20 x 5 mm

Case Protection:
IP 40 (IEC 529)

Drop Test:
Test per IEC 68-2-32: 1.0 m drop on 38 mm of Oak on concrete.

Mechanical Shock:
Test per IEC 68-2-27

Vibration:
Test per IEC 68-2-6

Dimensions:

5.47 x 2.00 x 1.18" (139 x 51 x 30 mm)

Weight: 180 g (6.5 oz)

Polycarbonate Material:

Jaws: Polycarbonate with 10% fiberglass charge,
Red UL 94 V0
Case: Polycarbonate 920A Gray

Opening Operations - Life: > 50,000

Output:

MN250: Two standard safety banana jacks (4 mm)
MN251: Double/reinforced insulated 5 ft. (1.5 m)
lead with safety 4mm banana plug

SAFETY SPECIFICATIONS



Electrical:

Double insulation or reinforced insulation between the primary or secondary and the outer case of the handle conforms to IEC 1010-2-32.

Common Mode Voltage:
600V CAT III, Pollution Degree 2

Dielectric Strength:
5550V, 50/60 Hz between primary, secondary and the outer case of the handle

Electromagnetic Compatibility:
EN 50081-1 Class B
EN 50082-2 Electrostatic discharge IEC 1000-4-2
Radiated field IEC 1000-4-3
Fast transients IEC 1000-4-4
Magnetic field at 50/60 Hz IEC 1000-4-8

ORDERING INFORMATION

AC Current Probe MN250 Cat #2115.76
AC Current Probe MN251 Cat #2115.77

Accessories:

Leads, set of 2, 5 ft safety (1000V) for Model MN250..... **Cat #2111.29**
Banana plug adapter (to non-recessed plug) **Cat #1017.45**

OPERATION

Please make sure that you have already read and fully understand the WARNING section on page 1.

Making Measurements with the AC Current Probe Model MN250/MN251:

- Connect the black lead of the current probe to “common” and the red lead to the AC voltage input on your DMM or other voltage-measuring instrument. The AC current probe has an output of 1mV/A. This means that for 200A AC in a conductor around which the probe is clamped, 200 mV AC will come out of the probe leads to your DMM or instrument. Select the range which corresponds to the measured current. If the current magnitude is unknown, start with the highest range and work down until the appropriate range and resolution are reached. Clamp the probe around the conductor. Take the reading on the meter and multiply it by 1000 to obtain the measured current (e.g. 150mV reading = 150 x 1000 = 150,000mA or 150A).
- For best accuracy, avoid if possible, the proximity of other conductors which may create noise.

Tips for Making Precise Measurements:

- When using a current probe with a meter, it is important to select the range that provides the best resolution. Failure to do this may result in measurement errors.
- Make sure that probe jaw mating surfaces are free of dust and contamination. Contaminants cause air gaps between the jaws, increasing the phase shift between primary and secondary. It is very critical for power measurement.

MAINTENANCE

Warning:

- For maintenance use only original factory replacement parts.
- To avoid electrical shock, do not attempt to perform any servicing unless you are qualified to do so.
- To avoid electrical shock and/or damage to the instrument, do not get water or other foreign agents into the probe.

Cleaning:

To ensure optimum performance, it is important to keep the probe jaw mating surfaces clean at all times. Failure to do so may result in error in readings. To clean the probe jaws, use very fine sand paper (fine 600) to avoid scratching the jaw, then gently clean with a soft oiled cloth.

REPAIR AND CALIBRATION

You must contact our Service Center for a Customer Service Authorization number (CSA#). This will ensure that when your instrument arrives, it will be tracked and processed promptly. Please write the CSA# on the outside of the shipping container.

Chauvin Arnoux[®], Inc. d.b.a. AEMC[®] Instruments
15 Faraday Drive • Dover, NH 03820 USA
(800) 945-2362 (Ext. 360) • (603) 749-6434 (Ext. 360) • repair@aemc.com

(Or contact your authorized distributor)

NOTE: All customers must obtain a CSA# before returning any instrument.

TECHNICAL AND SALES ASSISTANCE

If you are experiencing any technical problems, or require any assistance with the proper use or application of this instrument, please contact our technical hotline:

(800) 945-2362 (Ext. 351) • (603) 749-6434 (Ext. 351) • techsupport@aemc.com

LIMITED WARRANTY

The current probe is warranted to the owner for a period of two years from the date of original purchase against defects in manufacture. This limited warranty is given by AEMC[®] Instruments, not by the distributor from whom it was purchased. This warranty is void if the unit has been tampered with, abused or if the defect is related to service not performed by AEMC[®] Instruments.

Full warranty coverage and product registration is available on our website at: www.aemc.com/warranty.html.

Please print the online Warranty Coverage Information for your records.