

AC Current Oscilloscope Probe Model MN261



CURRENT MEASUREMENT PROBE

Copyright© Chauvin Arnoux®, Inc. d.b.a. AEMC® Instruments. All rights reserved.

No part of this documentation may be reproduced in any form or by any means (including electronic storage and retrieval or translation into any other language) without prior agreement and written consent from Chauvin Arnoux®, Inc., as governed by United States and International copyright laws.

Chauvin Arnoux®, Inc. d.b.a. AEMC® Instruments
15 Faraday Drive • Dover, NH 03820 USA
Tel: (800) 945-2362 or (603) 749-6434 • Fax: (603) 742-2346

This documentation is provided “as is,” without warranty of any kind, express, implied, or otherwise. Chauvin Arnoux®, Inc. has made every reasonable effort to ensure that this documentation is accurate; but does not warrant the accuracy or completeness of the text, graphics, or other information contained in this documentation. Chauvin Arnoux®, Inc. shall not be liable for any damages, special, indirect, incidental, or inconsequential; including (but not limited to) physical, emotional or monetary damages due to lost revenues or lost profits that may result from the use of this documentation, whether or not the user of the documentation has been advised of the possibility of such damages.

Statement of Compliance

Chauvin Arnoux[®], Inc. d.b.a. AEMC[®] Instruments certifies that this instrument has been calibrated using standards and instruments traceable to international standards.

We guarantee that at the time of shipping your instrument has met its published specifications.

An NIST traceable certificate may be requested at the time of purchase, or obtained by returning the instrument to our repair and calibration facility, for a nominal charge.

The recommended calibration interval for this instrument is 12 months and begins on the date of receipt by the customer. For recalibration, please use our calibration services. Refer to our repair and calibration section at www.aemc.com.

Serial #: _____

Catalog #: 2115.82

Model #: MN261

Please fill in the appropriate date as indicated:

Date Received: _____

Date Calibration Due: _____



Chauvin Arnoux[®], Inc.
d.b.a AEMC[®] Instruments
www.aemc.com

TABLE OF CONTENTS







1. INTRODUCTION.....	5
1.1 RECEIVING YOUR SHIPMENT	6
1.2 ORDERING INFORMATION	6
1.2.1 Accessories and Replacement Parts	6
2. PRODUCT FEATURES.....	7
2.1 DESCRIPTION	7
2.2 COMPATIBILITY	7
2.3 CONTROL FEATURES	8
3. SPECIFICATIONS.....	9
3.1 ELECTRICAL SPECIFICATIONS	9
3.2 MECHANICAL SPECIFICATIONS	10
3.3 ENVIRONMENTAL SPECIFICATIONS.....	10
3.4 SAFETY SPECIFICATIONS	10
3.5 TYPICAL RESPONSE CURVES.....	11
4. OPERATION	13
4.1 CURRENT MEASUREMENT	13
5. MAINTENANCE	14
5.1 CLEANING.....	14
5.2 REPAIR AND CALIBRATION	15
5.3 TECHNICAL ASSISTANCE	15
5.4 LIMITED WARRANTY	16
5.4.1 Warranty Repairs.....	16

1. INTRODUCTION

Thank you for purchasing an AEMC® Instruments **AC Current Oscilloscope Probe Model MN261**.

For the best results from your instrument and for your safety, you must read the enclosed operating instructions carefully and comply with the precautions for use. Only qualified and trained operators should use this product.

Symbols and Definitions

	Signifies that the instrument is protected by double or reinforced insulation
	CAUTION - Risk of Danger! Indicates a WARNING . Whenever this symbol is present, the operator must refer to the user manual before operation
	Indicates a risk of electric shock. The voltage at the parts marked with this symbol may be dangerous
	Application or withdrawal authorized on conductors carrying dangerous voltages. Type A current sensor per IEC 61010-2-032
	Important information to acknowledge
	This product complies with the Low Voltage & Electromagnetic Compatibility European directives (73/23/CEE & 89/336/CEE)

Definition of Measurement Categories (CAT)

CAT IV corresponds to measurements performed at the primary electrical supply (< 1000 V).

Example: primary overcurrent protection devices, ripple control units, and meters.

CAT III corresponds to measurements performed in the building installation at the distribution level.

Example: hardwired equipment in fixed installation and circuit breakers.

CAT II corresponds to measurements performed on circuits directly connected to the electrical distribution system.

Example: measurements on household appliances and portable tools.

PRECAUTIONS FOR USE

These safety warnings are provided to ensure the safety of personnel and proper operation of the instrument.

- ◆ Connect the probe to the oscilloscope or voltage measuring instrument **before** clamping the probe around a conductor.
- ◆ Never use the probe on circuits rated higher than 600V, Cat III.
- ◆ Never leave the probe clamped around a conductor while not connected to an oscilloscope or voltage measuring instrument.
- ◆ Carefully center the conductor inside the probe jaws and ascertain that the probe is perpendicular to the conductor.
- ◆ Avoid, if possible, the proximity of other conductors which may create noise.
- ◆ Check the magnetic mating surfaces of the probe jaws; these should be free of dirt, rust, or other foreign matter.
- ◆ Do not use a probe which is cracked, damaged, or has defective leads.

1.1 RECEIVING YOUR SHIPMENT

Upon receiving your shipment, make sure that the contents are consistent with the packing list. Notify your distributor of any missing items. If the equipment appears to be damaged, file a claim immediately with the carrier and notify your distributor at once, giving a detailed description of any damage. Save the damaged packing container to substantiate your claim.

1.2 ORDERING INFORMATION

AC Current Oscilloscope Probe Model MN261.....**Cat. #2115.82**
Includes user manual and a product warranty and registration card.

1.2.1 Accessories and Replacement Parts

Adapter - BNC (Female) to 4 mm
Banana (Male) 600 V CAT III **Cat. #2119.94**

Order Accessories and Replacement Parts Directly Online

Check our Storefront at www.aemc.com/store for availability

2. PRODUCT FEATURES

2.1 DESCRIPTION

The AC Current Oscilloscope Probe Model MN261 expands oscilloscope applications in industrial or power environments, and is ideal for analysis and measurement of distorted current waveforms and harmonics.

The Model MN261 permits accurate display and measurement of currents from (0.1 to 240) Arms, 40 Hz to 10 kHz (with current derating) without breaking into the circuit. A passive filter eliminates noise, ring on rapid rising (di/dt) waveforms, and ensures accurate screen displays.

The probe connects directly to an oscilloscope through an insulated coaxial cable with an insulated BNC.

2.2 COMPATIBILITY

The Model MN261 is compatible with any analog or digital oscilloscope or other voltage-measuring instrument which has the following features:

- BNC input connector
- Range capable of displaying (0.2 to 0.5) V per division, or 2 V range
- Minimum input impedance of 1 M Ω

2.3 CONTROL FEATURES

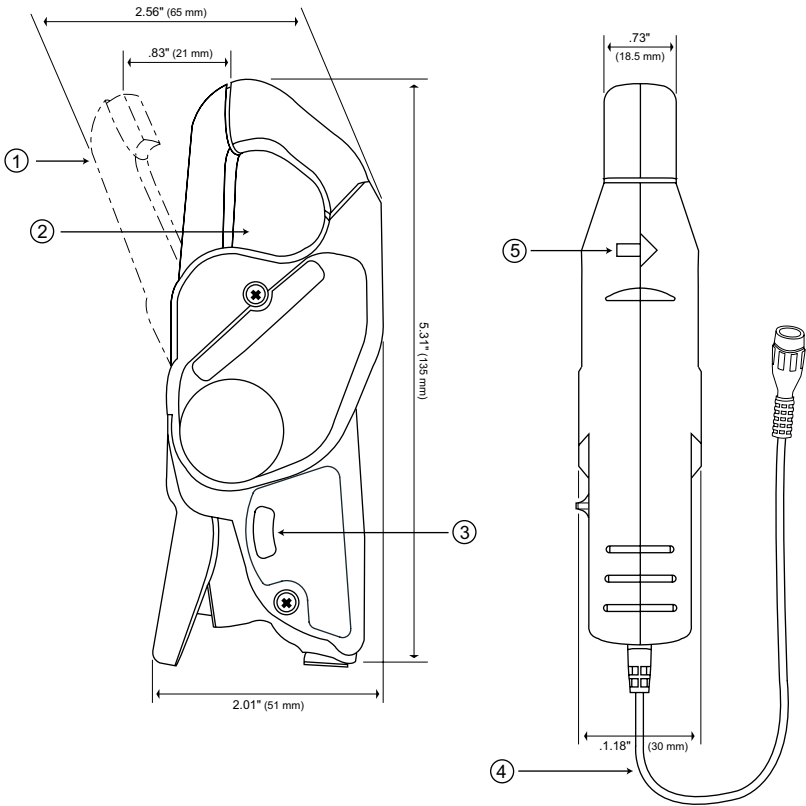

1. Jaw Opening: 0.83 in (21 mm)
2. Maximum dimension of conductor: 0.78 in (20 mm)
3. Two position switch
4. 6.5 ft (2 m) output cable
5. Arrow indicates direction of current flow. Current flows in a positive direction when it travels from supply to load.

3. SPECIFICATIONS

3.1 ELECTRICAL SPECIFICATIONS

*Reference conditions: 23 °C ± 3 °K, 20 to 75 % RH, 48 to 65 Hz, external magnetic field < 40 A/m, no DC component, no external current carrying conductor, test sample centered.

Current Range: 0.1 to 24 Arms
0.5 to 240 Arms

Output Signal: mV output signal; 2 range switch selectable on handle

100mV/A: 0.1 to 24 Arms

10mV/A: 0.5 to 240 Arms

Load Impedance: ≥ 1 MΩ @ ≤ 100 pF

Range: 10 mV/A (2 V at 200 A)

Primary Current	(0.5 to 10) A	(10 to 40) A	(40 to 100) A	(100 to 240) A
Accuracy	≤ 3.5 % ± 5 mV	≤ 3 % ± 5 mV	≤ 2.5 % ± 5 mV	≤ 1.5 % ± 5 mV
Phase Shift	N/A	≤ 6 °	≤ 4 °	≤ 3 °

Overload: 240 A for 10 mn ON, 30 mn OFF

Range: 100 mV/A (2 V at 20 A)

Overload: 120 A continuous

Accuracy: 2 % ± 50 mV

Phase Shift: not specified

Frequency Range (with current derating): 40 Hz to 10 kHz (@ -3 dB)

See Typical Response Curves (§ 3.5)

Load Impedance: 100 kΩ min

Working Voltage: 600 V CAT III

Common Mode Voltage: 600 V CAT III

Influence of Adjacent Conductor: <15 mA/AAC @ 50 Hz

Influence of Conductor Position in Jaw Opening:

0.5 % of Reading @ ((50/60) Hz)

Influence of Frequency:

Range 20 A: 40 Hz to 1 kHz: 10 % of mV output
(1 to 10) kHz: 15% of mV output

Range 200 A: 40 Hz to 1 kHz: 3% of mV output
(1 to 10) kHz: 12% of mV output

3.2 MECHANICAL SPECIFICATIONS

Dimensions: (5.47 x 2.00 x 1.18) in (139 x 51 x 30) mm

Weight: 6.5 oz (150g)

Maximum Cable Diameter: 0.78 in (20 mm)

Jaw Opening: 0.83 in (21 mm) max

Maximum Conductor Size: 0.78 in (20 mm)

Envelope Protection: IP 40 (IEC 529)

Drop Test: 1 m (IEC 68-2-32)

Mechanical Shock: 100 g (IEC 68-2-27)

Vibration: (10/55/10) Hz @ 0.15 mm (IEC 68-2-6)

Output: 6 ft (2 m) insulated lead with insulated BNC Connector

3.3 ENVIRONMENTAL SPECIFICATIONS

Operating Temperature/RH: (14 to 131) °F (-10 to 55) °C; < 85 % RH

Storage Temperature: (-40 to 158) °F (-40 to 70) °C

Influence of Temperature: ≤ 0.15 % / 10 K

Influence of Humidity: (10 to 90) %; 0.2 %

Altitude: ≤ 2000 m

3.4 SAFETY SPECIFICATIONS

Indoor Use



Electrical:

Double insulation or reinforced insulation between the primary or secondary and the outer case of the handle per EN 61010-2-032.

Common Mode Voltage: 600V, CAT III, Pollution Degree: 2

Electromagnetic Compatibility:

Emission and immunity in an industrial environment according to the standard EN61326-1.

**Specifications are subject to change without notice*

3.5 TYPICAL RESPONSE CURVES

10 mV/A Range

Accuracy vs. Frequency

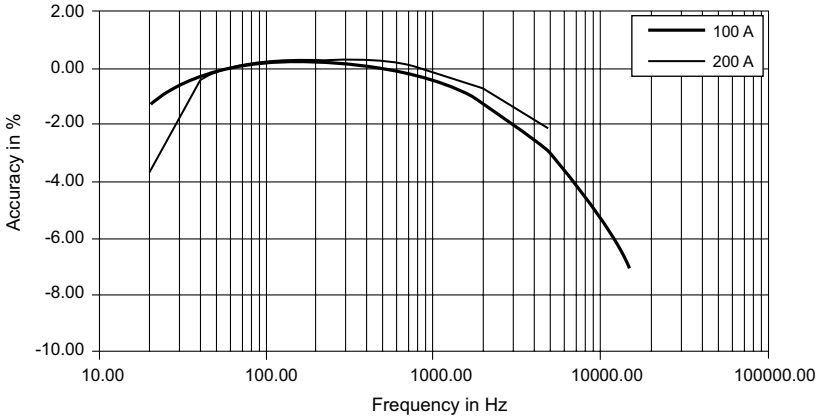

Phase Shift vs. Frequency

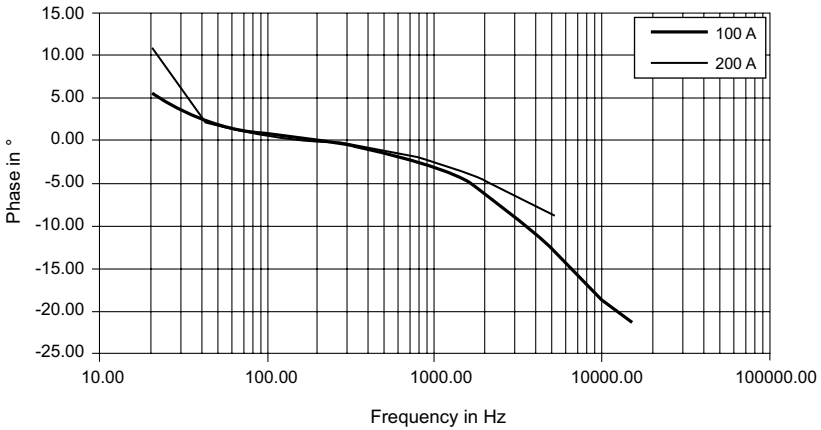

100 mV/A Range

Accuracy vs. Frequency

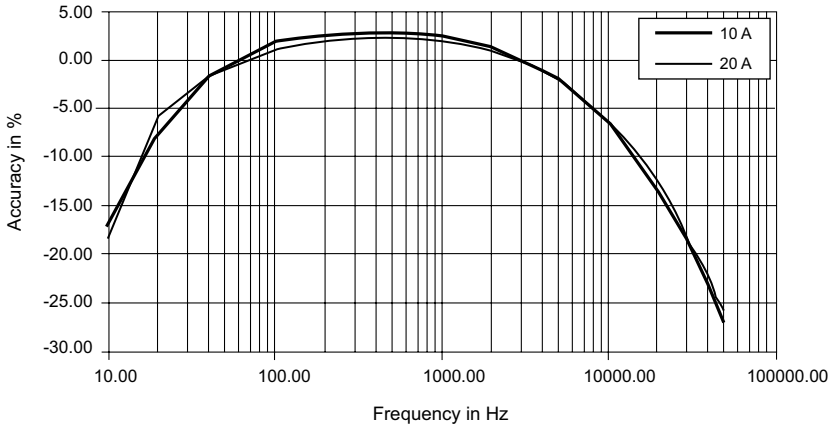

Phase Shift vs. Frequency

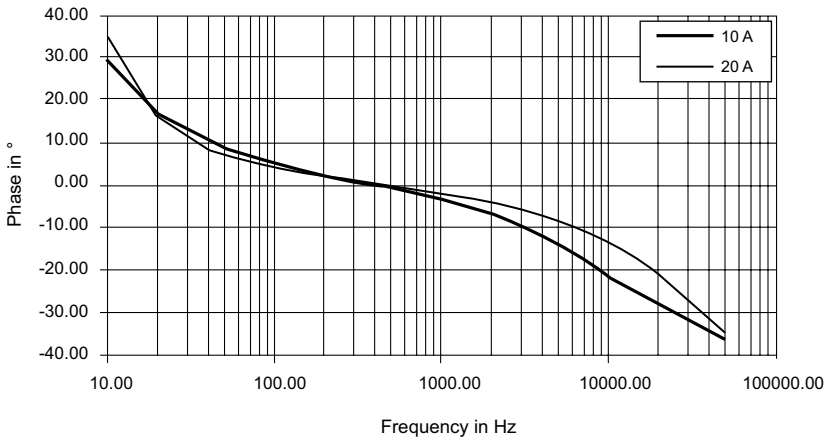

4. OPERATION

4.1 CURRENT MEASUREMENT



WARNING: Always connect the probe to the instrument before clamping onto the circuit under test.

Before measuring insulation resistance, confirm that the sample is fully

- Connect the Model MN261 to the proper input channel on the oscilloscope.
- Begin with the least sensitive range on the current probe (10 mV/A).
- Select the 0.5 V/Division range on the oscilloscope.
- Clamp the probe on the conductor to be measured and read the current flowing directly on your oscilloscope.

(Remember to unclamp the probe from the conductor before disconnecting it from your meter or instrument.)

You may also use your oscilloscope to amplify the signal while using the 1 mV/A probe range (which offers the best accuracy and least phase shift).



NOTE: It is possible to change the range on the current probe without removing the probe from the current carrying conductor, but it is important to remember not to exceed the permissible peak ratings of 340 mV peak or 680 mV peak to peak maximum. The peak ratings by range are: 34 A peak @ 100 mV/A and 340 A peak @ 10 mV/A.

5. MAINTENANCE



WARNING:

- ◆ To ensure optimum performance, it is important to keep the probe jaw mating surfaces clean at all times. Failure to do so may result in error in readings.
- ◆ For maintenance use only specified factory replacement parts.
- ◆ To avoid electrical shock, do not attempt to perform any servicing unless you are qualified to do so.
- ◆ To avoid electrical shock and/or damage to the instrument, do not allow water or other foreign substances into the case.
- ◆ Disconnect the unit from all circuits and test cables before opening the case.
- ◆ Use caution with metallic tools that may short battery packs, power supplies, etc.

5.1 CLEANING



WARNING: Before cleaning, disconnect all inputs to prevent possible electric shock.

- ◆ To clean the probe body, use a soft cloth dampened in a solution of mild detergent and water. To clean the core, open the jaw and clean the exposed core surfaces with a cotton swab dampened with isopropyl alcohol or ethyl alcohol. Lubricate the jaws mating surfaces with a light oil.
- ◆ Do not use chemicals containing benzene, benzene, toluene, xylene, acetone, or similar solvents.
- ◆ Do not immerse the probe in liquids or use abrasive cleaners.

5.2 REPAIR AND CALIBRATION

To ensure that your instrument meets factory specifications, we recommend that it be sent back to our factory Service Center at one-year intervals for recalibration or as required by other standards or internal procedures.

For instrument repair and calibration:

You must contact our Service Center for a Customer Service Authorization Number (CSA#). Send an email to repair@aemc.com requesting a CSA#, you will be provided a CSA Form and other required paperwork along with the next steps to complete the request. Then return the instrument along with the signed CSA Form. This will ensure that when your instrument arrives, it will be tracked and processed promptly. Please write the CSA# on the outside of the shipping container. If the instrument is returned for calibration, we need to know if you want a standard calibration or a calibration traceable to N.I.S.T. (includes calibration certificate plus recorded calibration data).

Ship To: Chauvin Arnoux®, Inc. d.b.a. AEMC® Instruments
15 Faraday Drive • Dover, NH 03820 USA
Phone: (800) 945-2362 (Ext. 360) / (603) 749-6434 (Ext. 360)
Fax: (603) 742-2346
E-mail: repair@aemc.com

(Or contact your authorized distributor.)

Contact us for the costs for repair, standard calibration, and calibration traceable to N.I.S.T.



NOTE: You must obtain a CSA# before returning any instrument.

5.3 TECHNICAL ASSISTANCE

If you are experiencing any technical problems or require any assistance with the proper operation or application of your instrument, please call, e-mail or fax our technical support team:

Chauvin Arnoux®, Inc. d.b.a. AEMC® Instruments
Phone: (800) 343-1391 (Ext. 351)
Fax: (603) 742-2346
E-mail: techsupport@aemc.com
www.aemc.com

5.4 LIMITED WARRANTY

The instrument is warranted to the owner for a period of two years from the date of original purchase against defects in manufacture. date of original purchase against defects in manufacture. This limited warranty is given by AEMC® Instruments, not by the distributor from whom it was purchased. This warranty is void if the unit has been tampered with, abused, or if the defect is related to service not performed by AEMC® Instruments.

Full warranty coverage and product registration is available on our website at www.aemc.com/warranty.html

Please print the online Warranty Coverage Information for your records.

What AEMC® Instruments will do:

If a malfunction occurs within the warranty period, you may return the instrument to us for repair, provided we have your warranty registration information on file or a proof of purchase. AEMC® Instruments will repair or replace the faulty material at our discretion.

REGISTER ONLINE AT: www.aemc.com/warranty.html

5.4.1 Warranty Repairs

What you must do to return an Instrument for Warranty Repair:

First, send an email to repair@aemc.com requesting a Customer Service Authorization Number (CSA#) from our Service Department. You will be provided a CSA Form and other required paperwork along with the next steps to complete the request. Then return the instrument along with the signed CSA Form. Please write the CSA# on the outside of the shipping container. Return the instrument, postage or shipment pre-paid to:

Chauvin Arnoux®, Inc. d.b.a. AEMC® Instruments
15 Faraday Drive, Dover, NH 03820 USA
Phone: (800) 945-2362 (Ext. 360) / (603) 749-6434 (Ext. 360)
Fax: (603) 742-2346
E-mail: repair@aemc.com

Caution: To protect yourself against in-transit loss, we recommend that you insure your returned material.



NOTE: You must obtain a CSA# before returning any instrument.

NOTES:

NOTES:

NOTES:



02/23

99-MAN 100144 v11

AEMC® Instruments

15 Faraday Drive • Dover, NH 03820 USA

Phone: (603) 749-6434 • (800) 343-1391 • Fax: (603) 742-2346

www.aemc.com