

AC/DC Current Probes

Model MR411

Model MR521

USER MANUAL

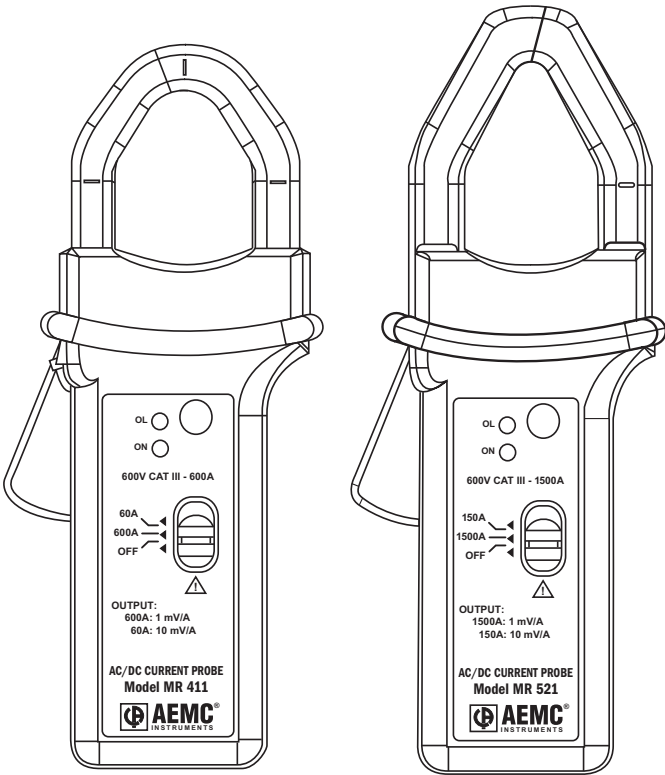

Statement of Compliance

Chauvin Arnoux®, Inc. d.b.a. AEMC® Instruments certifies that this instrument has been calibrated using standards and instruments traceable to international standards.

We guarantee that at the time of shipping your instrument has met its published specifications.

An NIST traceable certificate may be requested at the time of purchase, or obtained by returning the instrument to our repair and calibration facility, for a nominal charge.

The recommended calibration interval for this instrument is 12 months and begins on the date of receipt by the customer. For recalibration, please use our calibration services. Refer to our repair and calibration section at **www.aemc.com**.

Serial #: _____

Catalog #: 1200.68 / 1200.69

Model #: MR411 / MR521

Please fill in the appropriate date as indicated:

Date Received: _____

Date Calibration Due: _____



Chauvin Arnoux®, Inc.
d.b.a AEMC® Instruments
www.aemc.com

Table of Contents

Warning	2
International Electrical Symbols	2
Definition of Measurement Categories	3
Receiving Your Shipment	3
Description	3
Specifications	4
Model MR411 Features	9
Model MR521 Features	10
DMM/Display Compatibility	11
Operating Procedure	12
Making Measurements with the Model MR Probes	12
DC Measurement	12
AC Measurement	13
Indicator Lights	13
Auto-Off	13
Operation Examples	14
DC Current Measurement Example (MR411)	14
Measuring the DC Component of AC/DC Waveform (MR411)	15
Measuring the AC Component of AC/DC Waveform (MR521)	16
Tips for Making Precise Measurements	17
Typical Response Curves	18
Maintenance	20
Warning	20
Battery Replacement	20
Cleaning	20
Warranty	20
Repair and Calibration	(inside back cover)
Technical and Sales Assistance	(inside back cover)

 **Warning** 

- These safety warnings are provided to ensure the safety of personnel and proper operation of the instrument.
- Read the instruction manual completely and follow all the safety information before attempting to use or service this instrument.
- Use caution on any circuit: potentially high voltages and currents may be present and may pose a shock hazard.
- Read the safety specifications section before using the Model MR411 or MR521. NEVER exceed the maximum voltage ratings given.
- Safety is the responsibility of the operator.
- NEVER open the back of the instrument while connected to any circuit or input.
- ALWAYS connect the Model MR411 or MR521 to the display device before clamping the probe onto the sample under test.
- ALWAYS inspect the instrument and lead prior to use. Replace any defective parts immediately.
- NEVER use the Model MR411 or MR521 on electrical conductors rated above 600V.

International Electrical Symbols



This symbol signifies that the instrument is protected by double or reinforced insulation. Use only specified replacement parts when servicing the instrument.



This symbol signifies CAUTION! and requests that the user refer to the user manual before using the instrument.



Risk of electric shock. The voltage at the parts marked with this symbol may be dangerous.



This is a type A current sensor. This symbol signifies that application around and removal from HAZARDOUS LIVE conductors is permitted.

Definition of Measurement Categories

CAT II: For measurements performed on circuits directly connected to the electrical distribution system. Examples are measurements on household appliances or portable tools.

CAT III: For measurements performed in the building installation at the distribution level such as on hardwired equipment in fixed installation and circuit breakers.

CAT IV: For measurements performed at the primary electrical supply (<1000V) such as on primary overcurrent protection devices, ripple control units, or meters

Receiving Your Shipment

Both models include a 9V battery, warranty card and user manual.

Upon receiving your shipment, be sure that the contents are consistent with the packing list. Notify your distributor of any missing items. If the equipment appears to be damaged, file a claim immediately with the carrier and notify your distributor with a detailed description of any damage. Save the damaged packing container to substantiate your claim.

Description

The MR probes are designed to meet the latest safety and performance standards. Two different hook-shaped jaws are offered, both permitting the user to “pry” into or “hook” onto cables (will accept 2 x 500 MCM) or even smaller bus bars.

The MR series uses Hall effect technology. The electronics and batteries are self-contained in the handles. The output of the AC/DC probes is 1mV/A and 10mV/A. An auto zero push button ensures rapid and stable zeroing. There is no output filtering - True RMS with DC components is possible. Phase shift is excellent, making the MR series well suited for power and power quality applications.

Model MR411 is a portable 400A AC (600A peak), 600A DC current probe. Model MR521 is a portable 1000A AC (1500A peak), 1500A DC current probe that accurately measures AC or DC current waveforms using Hall effect technology.

Both models have proportional mV output for direct readings on multimeters, recorders, loggers and other instruments accepting banana plugs.

Specifications

MR411 Specifications

ELECTRICAL

Current Range:

60A range:

0.2 to 40A AC (60A Peak)

0.4 to 60A DC

600A range:

0.5 to 400A AC (600A Peak)

0.5 to 600A DC

Output Signal:

10mV/A on 60A range

1mV/A on 600A range

Accuracy and Phase Shift*:

60A Range:

0.5 to 40A: 1.5% reading \pm 0.5A

40 to 60A DC only:

1.5% reading

Phase Shift:

45 to 65Hz 10 to 20A: \leq 3.5°

20 to 40A: \leq 3°

600A Range:

0.5 to 100A: 1.5% reading \pm 1A

100 to 400A: 2.0% reading

400 to 600 DC only:

2.5% reading

Phase Shift:

45 to 65Hz 10 to 100A: \leq 3°

100 to 400A: \leq 2.5°

MR521 Specifications

ELECTRICAL

Current Range:

150A Range:

0.2 to 100A AC (150A Peak)

0.4 to 150A DC

1500A Range:

0.5 to 1000A AC (1400A Peak)

0.5 to 1500A DC

Output Signal:

10mV/A on 150A range

1mV/A on 1500A range

Accuracy and Phase Shift*:

150A Range:

0.5 to 100A: 1.5% reading \pm 0.5A

100 to 150A DC only:

2.5% reading.

Phase Shift:

45 to 65Hz 10 to 20A: \leq 3.5°

20 to 100A: \leq 3°

1500A Range:

1 to 100A: 1.5% reading \pm 1A

100 to 800A: 2.5% reading \pm 0.5A

800 to 1000A: 4% reading

1000 to 1200 DC only:

4% reading

Phase Shift:

45 to 65Hz 10 to 200A: \leq 3°

200 to 1000A: \leq 2.5°

(*Reference conditions: 18° to 28°C , 20 to 75% RH, external magnetic field <40 A/m, no DC component, no external current carrying conductor, test sample centered, $1M\Omega \leq$ 100 pF load, zero adjustment prior to measurement [DC only], DC to 65Hz. Battery voltage 9V \pm 0.1V)

MR411 Specifications, cont.

Overload: 1500A DC and 1000A AC continuous up to 1kHz

Noise:

60A Range:

DC to 1kHz: $\leq 8\text{mV}$

DC to 5kHz: $\leq 12\text{mV}$

0.1Hz to 5kHz: $\leq 2\text{mV}$

600A Range:

DC to 1kHz: $\leq 1\text{mV}$

DC to 5kHz: $\leq 1.5\text{mV}$

0.1Hz to 5kHz: $\leq 500\mu\text{V}$

Rise and Fall Time:

60A Range:

$\leq 100\mu\text{s}$ from 10 to 90% Vout

600A Range:

$\leq 70\mu\text{s}$ from 10 to 90% Vout

MECHANICAL

Humidity Influence:

10 to 90% RH @ reference temperature $\leq 0.5\%$

Maximum Cable Diameter:

One 1.18" (30mm) or two 0.95" (24mm) or two bus bars 1.24 x 0.39" (31.5 x 10mm)

Dimensions:

8.8 x 3.82 x 1.73"

(224 x 97 x 44mm)

Weight: 15oz (440g)

MR521 Specifications, cont.

Overload: 1500A DC and 1000A AC continuous up to 1kHz

Noise:

150A Range:

DC to 1kHz: $\leq 8\text{mV}$

DC to 5kHz: $\leq 12\text{mV}$

0.1Hz to 5kHz: $\leq 2\text{mV}$

1500A Range:

DC to 1kHz: $\leq 1\text{mV}$

DC to 5kHz: $\leq 1.5\text{mV}$

0.1Hz to 5kHz: $\leq 500\mu\text{V}$

Rise and Fall Time:

150A Range:

$\leq 100\mu\text{s}$ from 10 to 90% Vout

1500A Range:

$\leq 70\mu\text{s}$ from 10 to 90% Vout

MECHANICAL

Humidity Influence:

10 to 90% RH @ reference temperature $\leq 0.1\%$

Maximum Cable Diameter:

One 1.6" (42mm) or two 0.98" (25.4mm) or two bus bars 1.96 x 0.19" (50 x 5mm)

Dimensions:

9.31 x 3.82 x 1.73"

(236.5 x 97 x 44mm)

Weight: 16oz (480g)

Common Specifications (MR411 & MR521)

ELECTRICAL

Frequency Range: DC to 10kHz at -3dB

Load Impedance: >100k Ω /100 pF

Insertion Impedance: 0.39M Ω @ 50 Hz, 58M Ω @1000Hz

Working Voltage: 600Vrms

Common Mode Voltage: 600Vrms

Influence of Adjacent Conductor:
< 10mA/A at 50Hz at 23mm from the probe

Influence of Conductor in Jaw Opening:
0.5% reading (DC to 440Hz)

Battery: 9V alkaline (NEDA 1604A, IEC 6LR61) recommended

Low Battery: Green LED when battery voltage \geq 6.5V

Battery Life: Approx. 100H typical

Overload Indication:
Red LED indicates input greater than the selected range

Auto-Off: 10 minutes (may be disabled at power-up by pressing Zero button while turning on; green LED blinks three times to indicate that auto-off is disabled)

MECHANICAL

Operating Temperature Range:
14° to 131°F (-10° to 55°C)

Storage Temperature Range:
-40° to 176°F (-40° to 80°C)

Temperature Influence:
40mA/10K typical
 \leq 300ppm/°K or 0.3%/10°K

Operating Relative Humidity:

10-35°C: 90% ±5% RH (without condensation)

40-55°C: 70% ±5% RH (without condensation)

RH Influence:

10-35°C: 90% RH at reference

Temperature: ≤ 0.5% (MR411)

≤ 0.1% (MR521)

Altitude: Operating: 0 to 2000m

Non-operating: 0 to 12,000m

Zero Adjustment: Automatic zero (± 10) A by simple push button increments of 25 to 40mA. Red LED goes on at push of the button and turns off when zero is reached; no need to the hold button down.

Case protection: IP30 per IEC529

Drop Test:

1.0m on 38mm of oak on concrete; test according to IEC 1010

Mechanical Shock:

100G, test per IEC 68-2-27

Vibration: Test Per IEC 68-2-6,

Frequency Range:

5 to 15Hz, amplitude: 1.5mm

15 to 25Hz, amplitude 1mm

25 to 55Hz, amplitude: 0.25mm

Handle: UL94 V0

Jaws: UL94 V0

Color: Dark gray with red jaws

Output:

Double/reinforced insulated 5ft (1.5m) with safety 4mm banana plug

SAFETY

Double insulation or reinforced insulation between primary, secondary and outer case of handle per IEC 1010-2-032



- 600V Category III, Pollution: 2
- 7850V DC dielectric between primary or secondary and outer hand-held case

Electromagnetic Compatibility:

- Susceptibility in accordance with EN 50082-2 and EN 50082-1
- Electrostatic discharge IEC 1000-4-2
Test voltages: 4kV level 2 in contact, aptitude criteria B
8kV level 3 in the air, aptitude criteria B
- Radiated Field IEC 1000-4-3 (1995):
With max. interference of 5% of the measurement range:
3V/m level 3, aptitude criteria A
- Fast transients IEC 1000-4-4 (1995):
Test voltage: 1kV level 2, aptitude criteria B
- Magnetic fields at the frequency of the network to IEC 1000-4-8 (1995): With a max. distortion of 0.5A: 30A/m 50Hz level 4, aptitude criteria A
- Emissions in accordance with EN 50081-1:
- Radiated emission through the case to EN 55022 (1994): class B
- Conducted emission to EN 55022 (1994): class B

MR411

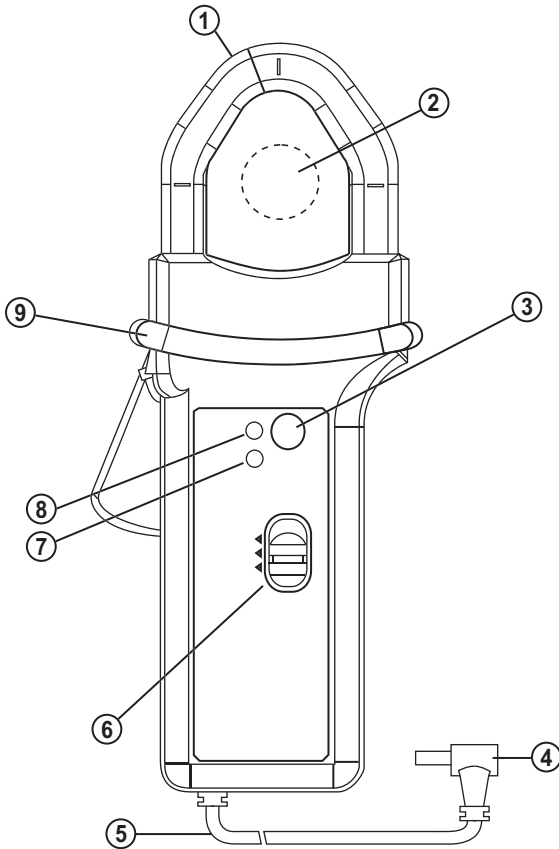

Figure 1

- | | |
|---|--|
| 1. Jaws | 7. Green light (on when battery voltage $\geq 6.5V$) |
| 2. Conductor | 8. Red light (overrange and incorrect zero adjustment) |
| 3. Automatic zero DC button | 9. Protective non-slip guard |
| 4. Safety banana plug $\varnothing 4mm$ | |
| 5. Lead, 5ft (1.5m) | |
| 6. Range selection switch: <ul style="list-style-type: none"> • On/Off • 600A (1mV/A) • 60A (10mV/A) | |

MR521

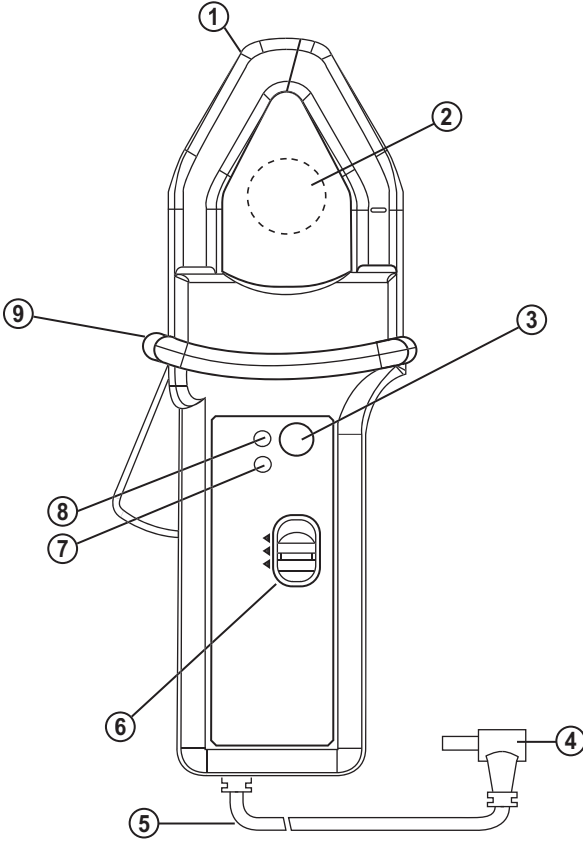

Figure 2

- | | |
|---|--|
| 1. Jaws | 7. Green light (on when battery voltage $\geq 6.5V$) |
| 2. Conductor | 8. Red light (overrange and incorrect zero adjustment) |
| 3. Automatic zero DC button | 9. Protective non-slip guard |
| 4. Safety banana plug \varnothing 4mm | |
| 5. Lead, 5ft (1.5m) | |
| 6. Range selection switch: | |
| • On/Off | |
| • 1500A (1mV/A) | |
| • 150A (10mV/A) | |

DMM/Display Compatibility

The Models MR411 and MR521 current probes are compatible with any multimeter voltmeter or other voltage measuring instrument which has the following features:

- Input jack that accepts 4mm safety banana plug
- Range and resolution capable of displaying 1mV of output per amp of measured current
- Voltmeter accuracy of 0.3% or better to take full advantage of the probe accuracy
- Input impedance of $1M\Omega/100pF$ or greater

When the probe is making a measurement, the current-carrying conductor is not broken and remains electrically isolated from the probe output. As a result, the probe output common may be either floated (isolated) or grounded.



Warning: User Safety:

Always use a DMM, voltmeter or other display, appropriately rated for safety.

Operating Procedure

Making Measurements with the Models MR411 and MR521

- Plug the probe into the display device (e.g., DMM, logger). Note the polarity of the probe output banana plugs (red = positive [+], black = negative [-]).
- Select the appropriate range on the display device. Note that the probe's outputs are 1mV/A and 10mV/A AC or DC. Note the maximum current capability on 10mV/A range.
- Turn display device power on. Turn on the Model MR: the green LED should be on, and the red LED off. If the green indicator does not come on or goes off before the probe has operated for 10 minutes, it is necessary to replace the battery (see "Battery Replacement," pg. 20).
- After approximately 10 minutes of operation, if none of the control buttons has been manipulated power will automatically shut off (see "Auto-Off" on next page).

DC Measurement

- Select the appropriate DC mV or V range on the DMM or measuring instrument.
- "Zero" the probe. With the probe disconnected from test samples (no conductor in probe jaw window), press the auto zero button. The red LED (%) comes on for approximately three seconds to indicate that the probe is zeroing. If the red LED remains lit, this indicates that zero has not been attained - repeat the zeroing operation.
- For best accuracy, especially on low-level measurement, it is recommended that you zero the probe before each measurement.
- Clamp the probe around the conductor to be tested. The DMM or display device should now display the measured conductor current. A positive reading indicates current flowing in the direction of the arrow located on the side of the jaw. A negative reading indicates current flow in the opposite direction of the arrow. Apply the conversion ratio (1mV/A or 10mV/A) to get the value of the current.

AC Measurement

- Select the appropriate AC mV or V range on the DMM or measuring instrument.
- The DC zero adjustment is not required when measuring AC current with a voltmeter that is AC coupled. The DC zero adjustment is required if you are using a voltmeter that is DC coupled.
- Select the appropriate mV AC or V AC range on the DMM or measuring instrument.
- Clamp the probe around the conductor (1) to be tested. The display device should now display the measured conductor current. Apply the conversion ratio (1mV/A or 10mV/A) to get the value of the current.

Indicator Lights: Green LED and Red LED

- The green LED indicates that the probe is on and that the battery is good. The green LED will not light under low battery conditions. Replace the 9V battery if the green LED is not lit.
- The red LED indicates a momentary or continuous overload of the instrument. Readings taken while the red LED is on or flashing should be considered inaccurate. Momentary or continuous currents exceeding 60A peak on the 60A range or 600A peak on the 600A range for the Model MR411, and 150A peak on the 150A range or 1500A on the 1500A range for the Model MR521 will trigger the red LED.

Auto-Off

- The Models MR411 and MR521 have an Auto-Off feature which turns off the instrument after 10 minutes if no control has been used.
- When the probe is switched off by this automatic function, the switch must first be set to the off position before the probe may be powered up again.
- Auto-off may be disabled at power-up by the user. Simply press the auto zero button at the same time as moving the switch from the OFF position to one of the ranges. The green LED blinks three times to indicate that the auto-off is disabled.

Operation Examples

DC Current Measurement Example for Model MR411

- Conductor carrying 25A DC in the direction of the arrow
- DMM placed in DC volts mode
- DMM displays 250.0mV with the probe in the 60A (10mV/A) range

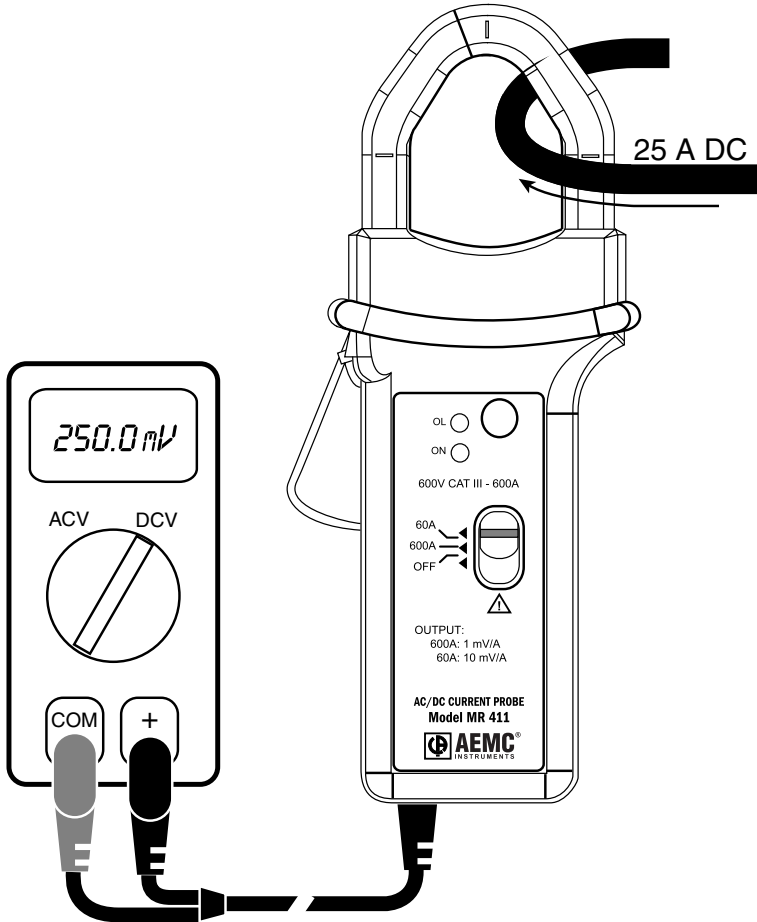

Figure 3

Measuring the DC Component of an (AC+DC) Waveform for Model MR411

- Conductor carrying 300A DC + 25.0A AC
- DMM placed in DC volts mode
- DMM displays 300.0mV with the probe in the 600A (1mV/A) range

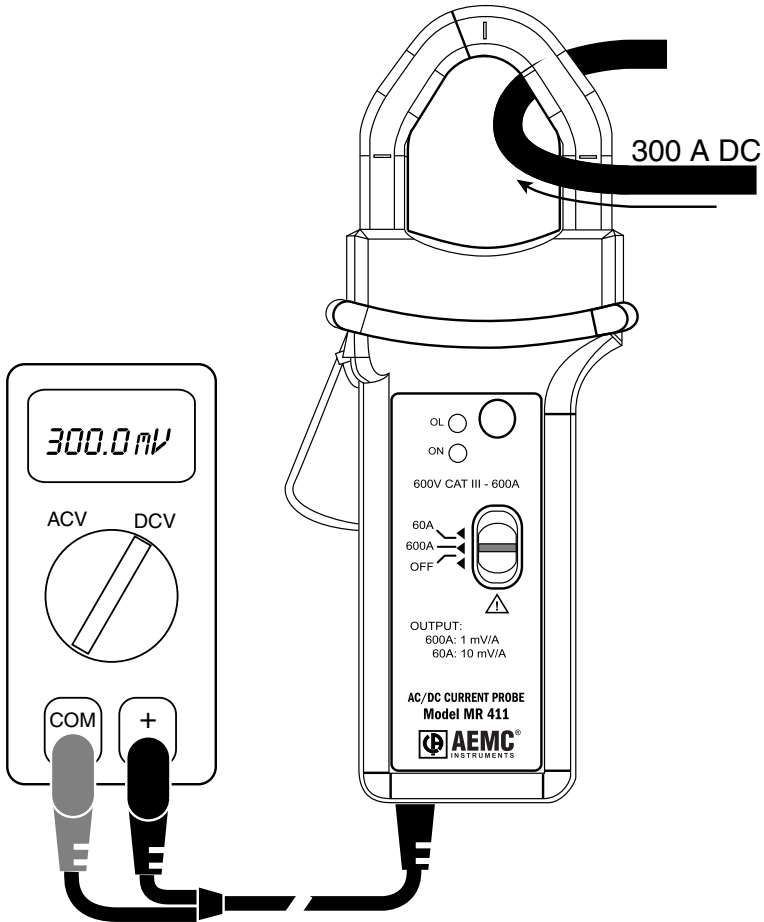

Figure 4

Measuring the AC Component of an (AC+DC) Waveform for Model MR521

- Conductor carrying 900A AC + 20A DC
- Voltmeter placed in AC volts mode
- Voltmeter displays 900.0mV with probe in the 1500A (1mV/A) range

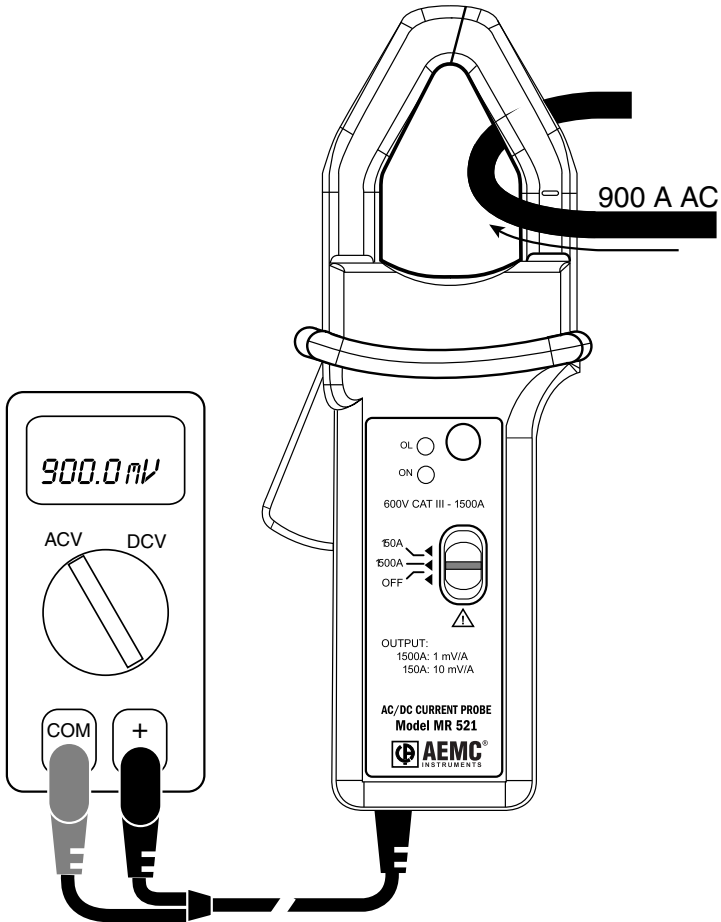

Figure 5

Tips For Getting the Best Accuracy

The Models MR411 and MR521 are capable of measuring DC and low frequency currents over a wide range. Here are some key considerations for getting the most accuracy from your display instrument:

- When using the Models MR411 and MR521 with a DMM or other meter, it is important to select the range that provides the best resolution.
- Make sure that probe jaw mating surfaces are free of dust and contamination.
- Beware of short-circuit currents. Large in-rush DC currents (which can occur when power is first applied in a circuit) and large high-current transients may cause varying degrees of residual readings. If in doubt of a particular reading, remove the probe from the conductor under test and check to see that the display device returns to zero. If not, it will be necessary to rezero the probe.

Typical Response Curves

Model MR411

Typical Accuracy on the 60 A DC Range

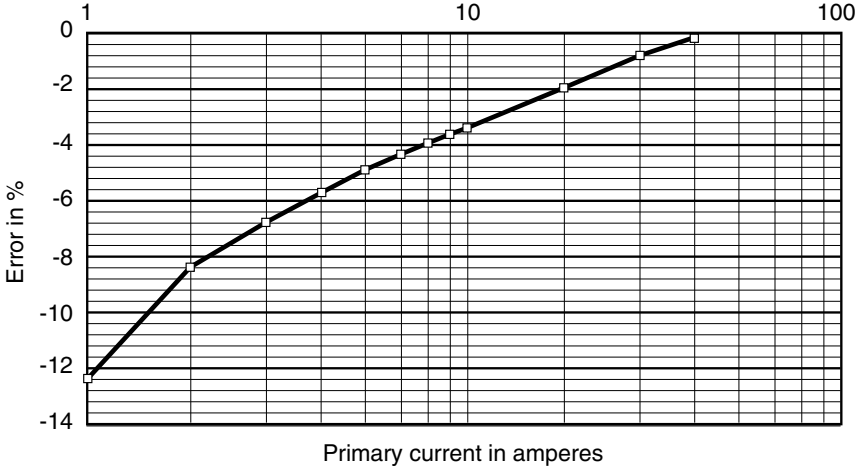

Typical Accuracy at 50 Hz: Range 60 A (10 mV/A)

Typical Accuracy on the 600 A DC Range

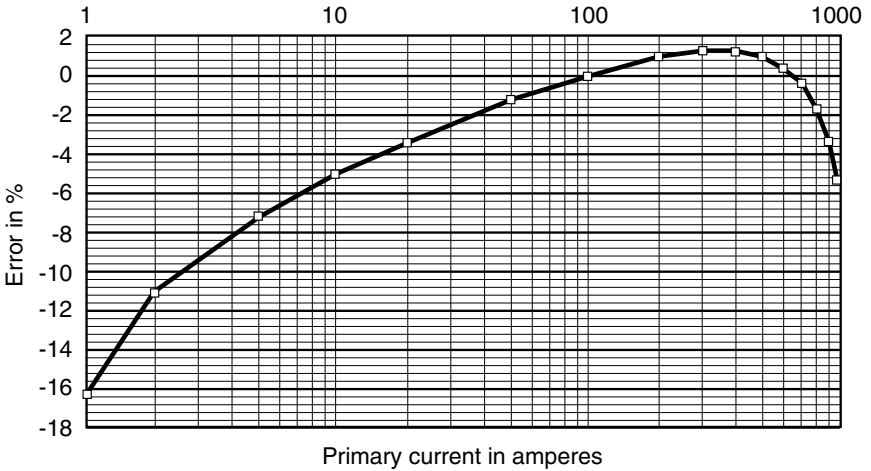

Typical Accuracy at 50 Hz: Range 600 A (1 mV/A)

Typical Response Curves

Model MR521

Typical Accuracy on the 150 A Range in DC

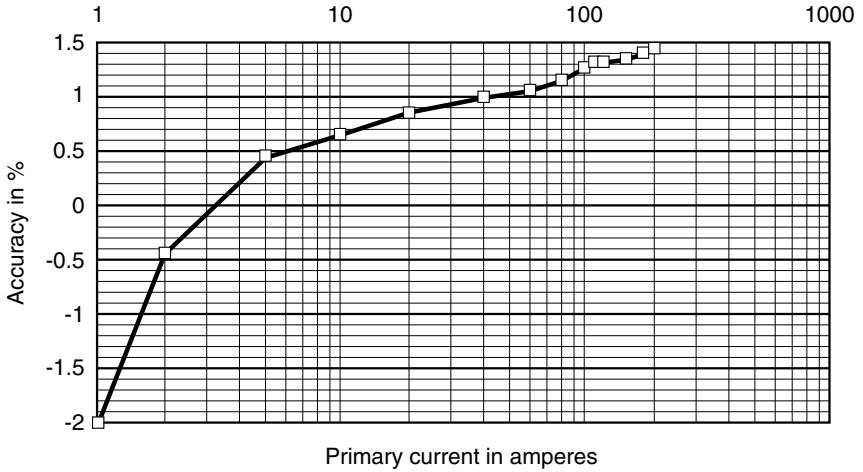

Typical Accuracy at 50 Hz: Range 150 A (10 mV/A)

Typical Accuracy on the 1500 A Range in DC

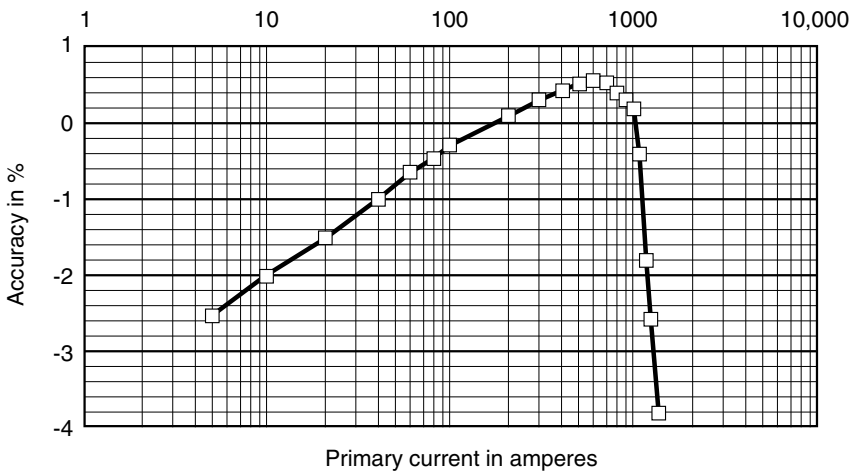

Typical Accuracy at 50 Hz: Range 1500 A (1 mV/A)

Maintenance

- For maintenance use only specified replacement parts.
- Avoid electrical shock: do not attempt to perform any servicing unless you are qualified to do so.
- Avoid electrical shock and/or damage to the instrument: do not get water or other foreign agents into the case. Turn the current probe OFF and disconnect the unit from all circuits before opening the case.

Battery Replacement

When the probe is turned on, the green LED should light up. If it does not, replace the 9V battery. Completely disconnect the probe from the circuit under test and from the DMM or measuring instrument. Turn the probe “Off”, unscrew the battery compartment screw and remove cover. Replace the battery and put the cover back on.

Do not replace the battery while the probe is in use.

Cleaning

Clean the body of the clamp with a cloth lightly moistened with soapy water. Wipe clean with a cloth moistened with clean water and dry. Do not use solvent.

Warranty

The Models MR411 and MR521 are warranted to the owner for a period of two years from the date of original purchase against defects in manufacture. This limited warranty is given by AEMC® Instruments, not by the distributor from whom it was purchased. This warranty is void if the unit has been tampered with, abused or if the defect is related to service not performed by AEMC® Instruments.

Full warranty coverage and product registration is available on our website at: www.aemc.com/warranty.html.

Please print the online Warranty Coverage Information for your records.

What AEMC® Instruments will do: If a malfunction occurs within the warranty period, you may return the instrument to us for repair, provided we have your warranty registration information on file or a proof of purchase. AEMC® will, at its option, repair or replace the faulty material.

Repair and Calibration

To ensure that your instrument meets factory specifications, we recommend that it be submitted to our factory Service Center at one-year intervals for recalibration, or as required by other standards or internal procedures.

For instrument repair and calibration:

You must contact our Service Center for a Customer Service Authorization number (CSA#). This will ensure that when your instrument arrives, it will be tracked and processed promptly. Please write the CSA# on the outside of the shipping container. If the instrument is returned for calibration, we need to know if you want a standard calibration, or a calibration traceable to N.I.S.T. (includes calibration certificate plus recorded calibration data).

Chauvin Arnoux[®], Inc.
d.b.a. AEMC[®] Instruments
15 Faraday Drive
Dover, NH 03820 USA
Tel: (800) 945-2362 (Ext. 360)
(603) 749-6434 (Ext. 360)
Fax: (603) 742-2346 or (603) 749-6309
repair@aemc.com

(Or contact your authorized distributor)

Costs for repair, standard calibration, and calibration traceable to N.I.S.T. are available.

NOTE: All customers must obtain a CSA# before returning any instrument.

Technical and Sales Assistance

If you are experiencing any technical problems, or require any assistance with the proper operation or application of your instrument, please call, mail, fax or e-mail our technical support hotline:

Chauvin Arnoux[®], Inc.
d.b.a. AEMC[®] Instruments
200 Foxborough Boulevard
Foxborough, MA 02035, USA
Phone: (800) 343-1391
(508) 698-2115
Fax: (508) 698-2118
techsupport@aemc.com
www.aemc.com

NOTE: Do not ship Instruments to our Foxborough, MA address.



Chauvin Arnoux[®], Inc. d.b.a AEMC[®] Instruments
15 Faraday Drive • Dover, NH 03820
www.aemc.com