

# 5000V Megohmmeters Models 5000N/5100/5110

USER MANUAL

---

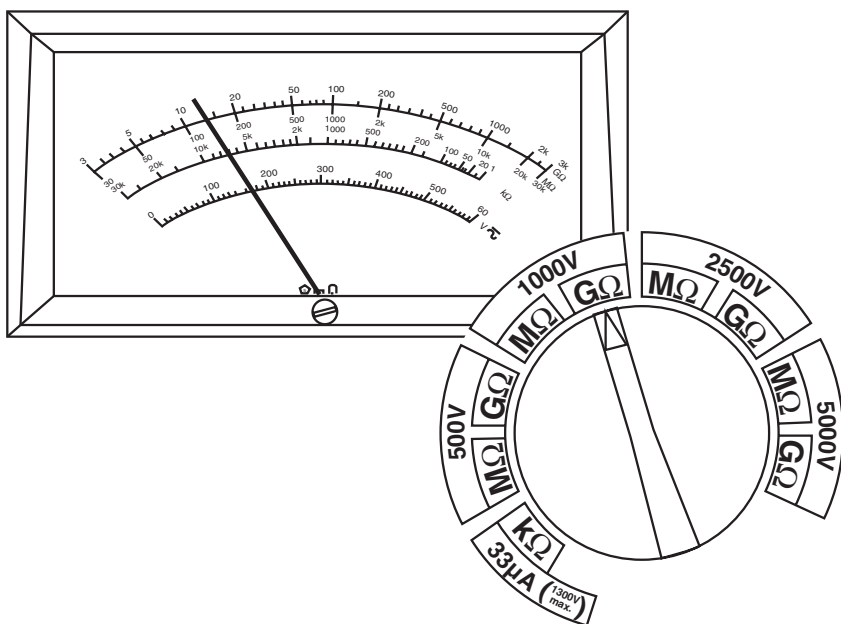



## Limited Warranty

The Megohmmeters Model 5000N, 5100 and 5110 are warranted to the owner for a period of 2 years from the date of original purchase against defects in manufacture. This limited warranty is given by AEMC® Instruments, not by the distributor from whom it was purchased. This warranty is void if the unit has been tampered with, abused or if the defect is related to service not performed by AEMC® Instruments.

**For full and detailed warranty coverage, please read the Warranty Coverage Information, which is attached to the Warranty Registration Card (if enclosed) or is available at [www.aemc.com](http://www.aemc.com). Please keep the Warranty Coverage Information with your records.**

### **What AEMC® Instruments will do:**

If a malfunction occurs within the warranty period, you may return the instrument to us for repair, provided we have your warranty registration information on file or a proof of purchase. AEMC® Instruments will, at its option, repair or replace the faulty material.

REGISTER ONLINE AT:  
[www.aemc.com](http://www.aemc.com)

## Warranty Repairs

### **What you must do to return an Instrument for Warranty Repair:**

First, request a Customer Service Authorization number (CSA#) by phone or by fax from our Service Department (see address below), then return the instrument along with the signed CSA Form. Please write the CSA number on the outside of the shipping container. Return the instrument, postage or shipment pre-paid to:

Chauvin Arnoux®, Inc. d.b.a. AEMC® Instruments  
Service Department  
15 Faraday Drive • Dover, NH 03820 USA

Tel: (800) 945-2362 (Ext. 360)  
(603) 749-6434 (Ext. 360)

Fax: (603) 742-2346 or (603) 749-6309

**Caution:** To protect yourself against in-transit loss, we recommend you insure your returned material.

**Note:** You must obtain a CSA# before returning any instrument.

## Table of Contents

Warning .....	4
International Electrical Symbols .....	4
<b>Megohmmeter Model 5000N .....</b>	<b>5</b>
Receiving Your Shipment.....	5
Ordering Information .....	5
Accessories And Replacement Parts.....	5
Description .....	6
Specifications .....	7
Control & Connector Identification .....	9
Battery Replacement.....	10
AC Supply Module .....	10
<b>Megohmmeter Model 5100/5110.....</b>	<b>11</b>
Receiving Your Shipment.....	11
Ordering Information .....	11
Accessories And Replacement Parts.....	11
Description .....	12
Specifications - Model 5100 .....	13
Specifications - Model 5110.....	15
Control & Connector Identification .....	17
AC Supply Module .....	18
Disassembly.....	19
Using the Clock/Timer.....	20
<b>Operation: Models 5000N, 5100 &amp; 5110.....</b>	<b>22</b>
The Analog Scale .....	22
Preliminary Check .....	23
How to use the Push-To-Test Button.....	23
Utilizing the Guard Terminal.....	24
Voltage Measurements (Safety Check) .....	25
Audible Signal .....	26
Precautions when making DC Insulation Tests .....	27
Insulation Measurement - Connections .....	27
Insulation Resistance Measurements on Motors .....	30

<b>Understanding Insulation Testing .....</b>	<b>32</b>
Ratio Testing .....	33
Types of Tests.....	34
Spot Reading Test .....	34
Polarization Index.....	35
Step Voltage Test.....	36
The Effects of Temperature .....	37
Interpreting the Results .....	38
<b>Maintenance .....</b>	<b>39</b>
Warning .....	39
Cleaning .....	39
<b>Repair And Calibration.....</b>	<b>40</b>
<b>Technical And Sales Assistance.....</b>	<b>40</b>

 **Warning** 

These safety warnings are provided to ensure the safety of personnel and proper operation of the instrument.



**WARNING: HIGH VOLTAGE PRESENT**

- Do not attempt to perform any tests with these instruments until you have read the instruction manual.
- Safety is the responsibility of the operator!
- Tests are to be carried out only on non-energized circuits! Check for live circuits before making resistance measurements (safety check).
- These Megohmmeters are sources of high voltage, as is the sample connected to them. All persons performing or assisting in the tests must employ all safety precautions to prevent electrical shock to themselves and to others.
- AEMC® considers the use of rubber gloves to be an excellent safety practice even if the equipment is properly operated and correctly grounded.
- When testing capacitance samples, make sure that they have been properly discharged and that they are safe to touch. Dielectric insulation samples should be short-circuited for at least five times the amount of time they were energized.
- Megohmmeters should never be used in an explosive environment.
- Use the leads supplied with the megohmmeters. If they are defective or worn, replace before testing.

## **International Electrical Symbols**



This symbol signifies that the instrument is protected by double or reinforced insulation. Use only specified replacement parts when servicing the instrument.



This symbol signifies CAUTION! and requests that the user refer to the user manual before using the instrument.



Risk of electric shock. The voltage at the parts marked with this symbol may be dangerous.

## **MEGOHMMETER MODEL 5000N**

### **Receiving Your Shipment**

Upon receiving your shipment, make sure that the contents are consistent with the packing list. Notify your distributor of any missing items. If the equipment appears to be damaged, file a claim immediately with the carrier and notify your distributor at once, giving a detailed description of any damage.

### **Ordering Information**

Megohmmeter Model 5000N..... **Cat. #186.100**  
Includes megohmmeter, eight 1.5V “AA” batteries, one shielded lead, two color-coded safety leads, insulated alligator clip, test probe batteries, spare fuse, carrying case and user manual.

### **Accessories and Replacement Parts**

AC power supply module with line cord and plug  
for switch-selectable 110/220VAC at 47 to 400Hz..... **Cat. #100.142**  
Protective rubber case with handle, safety yellow ..... **Cat. #2980.02**  
Fuse, set of five, 0.1A slow blow  
for AC supply module..... **Cat. #100.438**  
Fuse, set of one, 0.3A ..... **Cat. #100.429**  
Replacement lead, (green and blue clips) ..... **Cat. #1017.23**  
7-pin shielded lead, 10 ft  
for Models 1000N/5000N/5100 ..... **Cat. #2950.10**  
Probe and clip for Model 1000N/5000N ..... **Cat. #100.404**

## Description

AEMC® Instruments Model 5000N (Cat. #186.100) is a portable, multi-range, high-sensitivity megohmmeter capable of measuring a wide range of insulation resistances from 10 kilohms to 3000 gigohms (3,000,000 megohms). The Model 5000N has four test voltages of 500, 1000, 2500, and 5000 volts. Each test voltage setting has two overlapping resistance ranges of  $30\text{M}\Omega$  to  $30,000\text{M}\Omega$  and  $3\text{G}\Omega$  to  $3000\text{G}\Omega$  on a long (9.4") dial.

In addition, the Model 5000N has a unique low insulation test range of 10 to  $30,000\text{k}\Omega$  with a constant current of  $33\mu\text{A}$  (maximum voltage of 1300VDC), which is useful for testing old or flooded installations. A voltmeter (safety check) with a range of 0 to 600 volts is standard.

The Model 5000N may be powered by either AC or DC. DC power is supplied by eight 1.5V alkaline "AA" batteries. As an option, an AC line supply module and cord for 110/220VAC at 47 to 400Hz can be inserted in the battery compartment.

An audible signal, consisting of approximately ten beeps per minute, is present when the megohmmeter is ON, and serves as a time base for tests of long duration. A green LED, when ON, indicates that the batteries are good when the push-to-test button is depressed. It also serves as a warning light when the instrument is in use, indicating that the selected test voltage is present at the terminals.



## Specifications

### ***INSULATION TESTS***

**DC Test Voltages:**

500, 1000, 2500, 5000V

**Megohm Ranges:**

For each test voltage two direct reading ranges:

30 to 30,000M $\Omega$

3 to 3000G $\Omega$

(3000 to 3,000,000M $\Omega$ )

**Short Circuit Current:** 3mA (max)

**Accuracy:** 5% of reading typical

**Charging Time:**

M $\Omega$  range: 0.3 seconds/ $\mu$ F

G $\Omega$  range: 3 seconds/ $\mu$ F

**Discharging Time:**

Automatic discharge when test button is released; 0.1 seconds/ $\mu$ F

**Scale:**

Two large overlapping scales: 4.7" (119 mm) for each range

**Test Voltage Generation:**

Solid state circuitry generating rated test voltage across the full range

### ***RESISTANCE TESTS***

**Test Current:** Constant 33  $\mu$ A DC

**Kilohm Range:** 10 to 30,000k $\Omega$  (30M $\Omega$ )

**Maximum Test Voltage:** 1300VDC

**Accuracy:** 5% of reading typical

### ***VOLTAGE TESTS (SAFETY CHECK)***

**Voltage Range:** 0 to 600VAC/DC

**Accuracy:** 3% of full scale

## **GENERAL SPECIFICATIONS**

### **Audible Test Signal:**

Ten beeps per minute

### **Power Supply:**

Eight 1.5V "AA" alkaline batteries (NEDA 15A). Typical battery life: 350 one-minute tests; power consumed only when test button is depressed; built-in battery check by green LED.

#### *Option:*

110/220V selectable

47 to 400Hz AC supply module

**Dielectric Test:** 4000VAC, 60Hz, 1 minute

### **Fuse Protection:**

0.3A high interrupting capacity fuse between line and guard terminals

**Meter Movement:** Rugged taut band suspension

**Dimensions:** 7.7 x 5.2 x 3.75" (196 x 132 x 95mm)

**Weight:** 2.2 lbs (1 kg)

**Temperature Range:** 23° to 122°F (-5° to +50°C)

**Case:** High impact gray polycarbonate

### **Terminals:**

Color-coded safety terminals; guard terminal eliminates surface leakage errors

### **Electromagnetic Compatibility:**

CEI 801-2: Electrical Discharge  
Class II



CEI 801-3: Magnetic Fields 3 V/m

CEI 801-4: Rapid Transients Class II

CEI 801-5: Electrical Shock (5KV 2 Joules)

## Control & Connector Identification

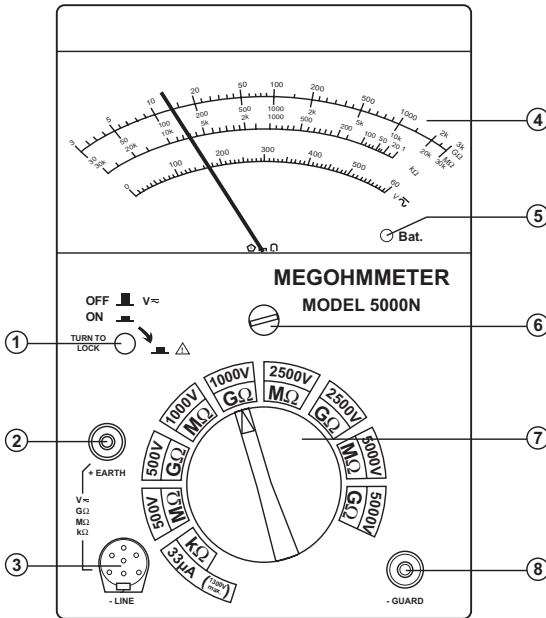

1. **PUSH-TO-TEST button**  
Lock "ON" by turning button a quarter turn to the right.  
OFF Position: Voltmeter position  
ON Position: Test position with voltage present at outputs
2. **EARTH terminal (green)**  
Connects to ground for insulation testing.
3. **LINE terminal (black)**  
Connects to the equipment to be tested.
4. **Analog Measurement Scale**
5. **Battery Power Indicator**  
Green light ON indicates that the batteries are good when the PUSH-TO-TEST button is depressed. Audible "beep" is also emitted approx every 6 seconds.
6. **Mechanical Zero Adjust**
7. **Selection Switch**
8. **GUARD terminal (blue)**  
Used to minimize the effect of leakage current.

## Battery Replacement

The Model 5000N is powered by eight 1.5V “AA” batteries. To replace the batteries, disconnect the instrument from any circuits, verify the PUSH-TO-TEST button is in the OFF position and proceed as follows:

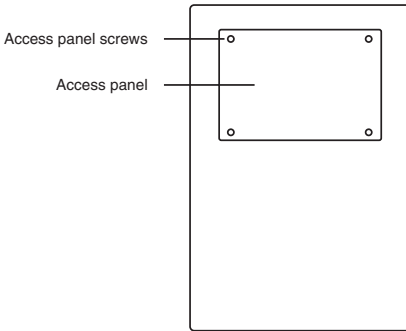

- Unscrew the four standard screws on the four corners of the battery pack and remove the battery pack.
- Replace the batteries, observing the proper polarities.
- Replace the battery case, taking care not to pinch the connecting wire, and tighten the four screws.

Figure 2

## AC Supply Module

The optional AC supply module (Cat. #100.142) provides power to the Model 5000N at 110 or 220VAC. The AC power supply module is designed to plug into the back portion of the instrument, directly replacing the batteries. The module is protected by a 0.1A slow-blow fuse.

**Note:** Cat. #100.142 is supplied with 110V US plug.

- Unscrew the four screws on the corners of the back panel battery pack.
- Disconnect and remove the battery pack.
- Connect the AC supply module to the power supply connector.
- Place the AC supply module into the back of the instrument and tighten the four corner screws, making sure not to pinch the wires of the power supply connector.
- With the tip of a screwdriver, select the proper voltage with the 110/220 supply switch on the back panel of the AC supply module
- Plug the AC supply cord into the appropriate voltage receptacle.

## **MEGOHMMETER MODEL 5100/5110**

### **Receiving Your Shipment**

Upon receiving your shipment, make sure that the contents are consistent with the packing list. Notify your distributor of any missing items. If the equipment appears to be damaged, file a claim immediately with the carrier and notify your distributor at once, giving a detailed description of any damage.

### **Ordering Information**

Megohmmeter Model 5100 ..... **Cat. #1396.07**

Megohmmeter Model 5110 ..... **Cat. #1396.08**

Both models include megohmmeter, set of three leads, hex key, 12V NiCad battery, 110VAC US line cord and instruction manual.

### **Accessories and Replacement Parts**

7-pin shielded lead, 10 ft,  
for Models 1000N/5000N/5100 ..... **Cat. #2950.10**

Color-coded safety leads, set of two, 10-ft..... **Cat. #2950.09**

7-pin Shielded lead, 25 ft,  
for Models 1100N/5000N/5100 ..... **Cat. #2118.26**

Safety leads, set of two 25 ft with alligator clips..... **Cat. #2118.27**

Fuse, set of five, 3.15 A ..... **Cat. #1007.26**

Rechargeable 12V NiCad battery ..... **Cat. #2960.10**

Safety leads,  
set of two 10 ft with heavy duty alligator clips ..... **Cat. #2950.23**

## Description

AEMC® Models 5100/5110 are portable, multi-range, high-sensitivity megohmmeters capable of measuring a wide range of insulation resistances from 10 kilohms to 3000 gigohms. The Model 5100 has four test voltages of 500, 1000, 2500, and 5000 volts. Each test voltage setting has two overlapping resistance ranges of  $30\text{M}\Omega$  to  $30,000\text{M}\Omega$  and  $3\text{G}\Omega$  to  $3000\text{G}\Omega$  ( $3,000,000\text{M}\Omega$ ). The Model 5110 features a color display and also has test voltages of 500, 1000, 2500, and 5000 volts. Each test voltage setting has two overlapping resistance ranges of  $3\text{M}\Omega$  to  $3000\text{M}\Omega$  and  $3\text{G}\Omega$  to  $3000\text{G}\Omega$  ( $3,000,000\text{M}\Omega$ ).

The Models 5100 and 5110 have a unique low insulation test range of 10 to  $30,000\text{k}\Omega$  with a constant current of  $33\mu\text{A}$  (maximum voltage of  $1300\text{V}_{\text{DC}}$ ), which is useful for testing old or flooded installations. A voltmeter (safety check) with a range of 0 to 600 volts is standard.

Both models feature a digital clock timer that indicates time and date. The timer allows accurate testing on time-based test applications. The timer may be programmed in one of two modes: to indicate the elapsed time of applied test voltage, or the time elapsed since the test voltage has been stopped (discharge time).

An audible signal consisting of approximately ten beeps per minute is present when the test voltage has been applied, and also serves as a time base for tests of long duration.

The Models 5100/5110 may be powered by either AC or DC. DC power is supplied by a 12V rechargeable nickel-cadmium battery. AC supply voltage may be either 110V or 220V via the removable line cord, which plugs directly into the front of the instrument. Neon lamps on the front panel indicate battery status; a green light indicates battery charge/AC supply, while a red light indicates the battery charge status.

The rugged field case in safety yellow is weatherproof and rainproof when closed. The instrument cover is also removable. The Models 5100/5110 are specifically designed for field, utility, and industrial use.

## **Specifications - Model 5100**

### ***INSULATION TESTS***

**DC Test Voltages:**

500, 1000, 2500, 5000V

**Megohm Ranges:**

For each test voltage two direct reading ranges:

30 to 30,000M $\Omega$

3 to 3000G $\Omega$

(3000 to 3,000,000M $\Omega$ )

**Short Circuit Current:** 6mA (max)

**Accuracy:** 5% of reading typical

**Charging Time:**

0.5 to 5 seconds/ $\mu$ F typical

**Discharging Time:**

Automatic discharge when test button is released; 0.1 seconds/ $\mu$ F.

Discharge voltage displayed on meter.

**Test Voltage Generation:**

Solid state circuitry generating rated test voltage across the full range

### ***RESISTANCE TESTS***

**Test Current:** Constant 33  $\mu$ A DC

**Kilohm Range:** 10 to 30,000k $\Omega$  (30M $\Omega$ )

**Maximum Test Voltage:** 1300VDC

**Accuracy:** 5% of reading typical

### ***VOLTAGE TESTS (SAFETY CHECK)***

**Voltage Range:** 0 to 600VAC/DC

**Accuracy:** 3% of full scale

## **GENERAL SPECIFICATIONS**

### **Audible Test Signal:**

Ten beeps per minute approx. (signal may be disabled)

### **Power Supply:**

Rechargeable 12V NiCad battery

Typical life: 500 to 2500 1 min tests (depending on test voltage)

Recharging time: 14 hrs (max) for full charge

Fuse protection: 3.15A fast blow

Low battery indicators

**AC Supply:** 110/220V, 47 to 450Hz AC  $\pm$  20%

**Dielectric Test:** 4000VAC, 60Hz, 1 minute

**Overload:** 600Vrms between one terminal and the other two

### **Meter Movement/Display:**

Rugged taut band suspension;

4.4 x 2.2" (112 x 55mm) meter with 4 scales

**Clock/Timer:** Test voltage ON activates timer automatically

**Dimensions:** 9.8 x 10.2 x 15.4" (250 x 260 x 390mm)

**Weight:** 14.8 lbs (6.7kg)

**Temperature Range:** 14° to 131°F (-10 to 55°C)

### **Field Case:**

High impact, fiberglass charged polycarbonate (fire resistant UL94);  
sealed and weatherproofed; rainproof when closed

### **Terminals:**

Color-coded safety terminals; guard terminal minimizes surface  
leakage errors

### **Safety Standards:**

4000V dielectric test

Double insulation

IEC 348

### **Electromagnetic Compatibility:**

CEI 801-2: Electrical Discharge. Class II

CEI 801-3: Magnetic Fields 3V/m

CEI 801-4: Rapid Transients class II

CEI 801-5: Electrical shock (5KV 2 Joules)





## **Specifications - Model 5110**

### ***INSULATION TESTS***

**DC Test Voltages:**

500, 1000, 2500, 5000V

**Megohm Ranges:**

For each test voltage two direct reading ranges:

3 to 3000M $\Omega$

3 to 3000G $\Omega$

**Short Circuit Current:** 6mA (max)

**Accuracy:** 5% of reading typical

**Charging Time:**

0.5 to 5 seconds/ $\mu$ F typical

**Discharging Time:**

Automatic discharge when test button is released; 0.1 seconds/ $\mu$ F.

Discharge voltage displayed on meter.

**Test Voltage Generation:**

Solid state circuitry generating rated test voltage across the full range

### ***RESISTANCE TESTS***

**Test Current:** Constant 33  $\mu$ A DC

**Kilohm Range:** 10 to 30,000k $\Omega$  (30M $\Omega$ )

**Maximum Test Voltage:** 1300VDC

**Accuracy:** 5% of reading typical

### ***VOLTAGE TESTS (SAFETY CHECK)***

**Voltage Range:** 0 to 600VAC/DC

**Accuracy:** 3% of full scale

## **GENERAL SPECIFICATIONS**

### **Audible Test Signal:**

Ten beeps per minute approx. (signal may be disabled)

### **Power Supply:**

Rechargeable 12V NiCad battery

Typical life: 500 to 2500 1 min tests (depending on test voltage)

Recharging time: 14 hrs (max) for full charge

Fuse protection: 3.15A fast blow

Low battery indicators

**AC Supply:** 110/220V, 47 to 450Hz AC  $\pm$  20%

**Dielectric Test:** 4000VAC, 60Hz, 1 minute

**Overload:** 600Vrms between one terminal and the other two

### **Meter Movement/Display:**

Rugged taut band suspension;

4.4 x 2.2" (112 x 55mm) meter with 4 scales

**Clock/Timer:** Test voltage ON activates timer automatically

**Dimensions:** 9.8 x 10.2 x 15.4" (250 x 260 x 390mm)

**Weight:** 14.8 lbs (6.7kg)

**Temperature Range:** 14° to 131°F (-10 to 55°C)

### **Field Case:**

High impact, fiberglass charged polycarbonate (fire resistant UL94);  
sealed and weatherproofed; rainproof when closed

### **Terminals:**

Color-coded safety terminals; guard terminal minimizes surface  
leakage errors

### **Safety Standards:**

4000V dielectric test

Double insulation

IEC 348

### **Electromagnetic Compatibility:**

CEI 801-2: Electrical Discharge. Class II

CEI 801-3: Magnetic Fields 3V/m

CEI 801-4: Rapid Transients class II

CEI 801-5: Electrical shock (5KV 2 Joules)



## Control & Connector Identification

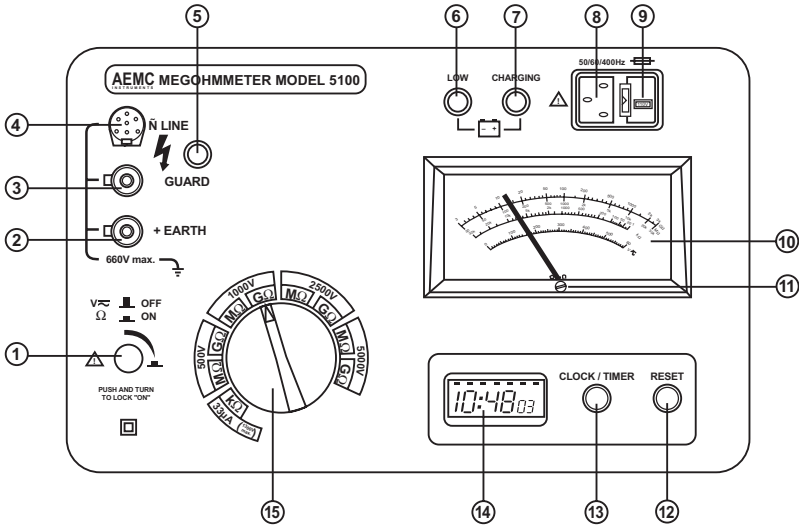

1. **PUSH-TO-TEST button:**  
Lock "ON" by turning button a quarter turn to the right.  
OFF Position: Voltmeter position.  
ON Position: Test position with voltage present at outputs.
2. **EARTH terminal (green):**  
Connects to ground for insulation testing.
3. **GUARD terminal (blue):**  
Used to minimize the effect of leakage current.
4. **LINE terminal (black):**  
Connects to the equipment to be tested.
5. **High Voltage Indicator:**  
Red light blinks when the measurement voltage is on the output terminals. An audible "beep" is also emitted approx. every 6 seconds.
6. **Battery Low Indicator:**  
Light OFF: battery good  
Light ON: battery partially discharged. (Measurements possible for 20-60 minutes depending on voltage selection. Clock and voltmeter still operational).

7. Charging Light:  
Indicates the battery is charging or operation from AC supply
8. Power Line Socket
9. Fuse Socket:  
Select 110/220V with small connector in this socket.  
**NOTE:** When switching the power supply between 110V and 220V, the selection module must be changed accordingly. Change fuse before making any connections.
10. Analog Measurement Scale (Model 5110 has color scale)
11. Zero Adjust
12. Reset Button:  
Resets chronometer and selects time values during programming.
13. Clock/Timer:  
Toggles between the clock and timer on the display.
14. LCD Display: Clock or timer.
15. Selection Switch

## AC Supply Module

Models 5100 and 5110 may be powered by 110V or 220VAC (47 to 450Hz). The instrument includes a 110V supply cord, which provides power to the instrument as well as charging voltage for the rechargeable battery. Verify that "110V" appears in the power supply module window opening; this will permit operation with the 110V supply cord.

To change the power supply voltage selection, push the tab on the selection module to the right and remove the module. Remove the portion of the module that contains the fuse assembly and rotate 180° to display "220V" in the module window. A 220V supply cord (not supplied) is required for 220V operation.



**CAUTION:** Do not change the power supply voltage while operating either Model 5100 or Model 5110 from the AC supply.

Both Models are protected by a 3.15A, 250V fuse (Cat. #1007.26).

## Disassembly

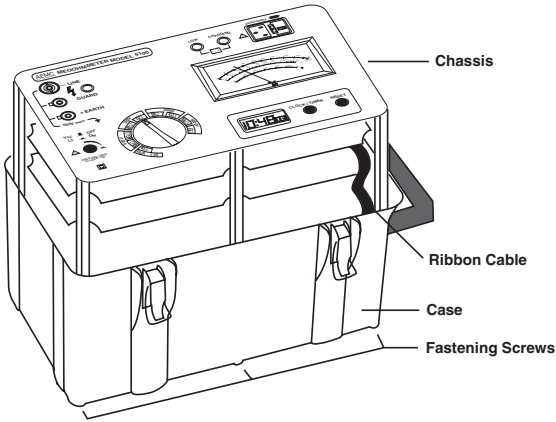

Figure 4

Use the hex key to unscrew the six fastening screws from the chassis, which are located on the bottom of the case.

Pull out the chassis. Do not forget to unplug the ribbon cable which connects the power supply board in the bottom of the case to the boards which are mounted in the chassis.

## Detachable Cover

The cover hinges are fitted with spring loaded clips which allow the cover to be removed. To detach the cover from the Models 5100 or 5110, open lid to a horizontal position and apply downward pressure to the hinge side of the cover while gripping it firmly.

To re-attach the cover, position the cover in a horizontal position and fit the hinges into the respective housing. Apply strong rear-to-front pressure to the cover until it snaps into place.

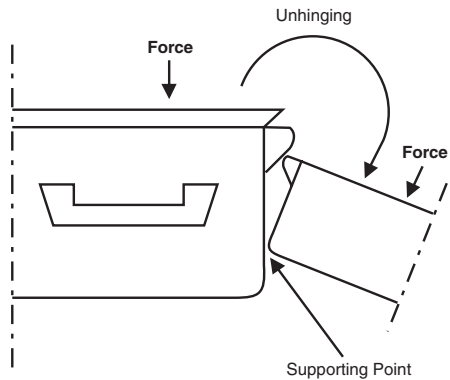

Figure 5

## Using the Clock/Timer

The clock/timer function may be used in three ways. First, a clock and calendar indicate the current time (12-hour format). Second, a timer may be used when performing insulation resistance tests that are dependent upon an accurate time reading (e.g. dielectric absorption, polarization index, step voltage). Third, the timer portion may be programmed as an ascending timer in relation to applied test voltage or in relation to the discharge time.

**Note:** Setting both the clock and timer requires the user to engage the push-to-test button to access different modes. Potentially dangerous voltage may be present. Select a position on the voltage selector switch between voltage ranges (e.g. vertical position between 1000V and 2500V). This eliminates the possibility of voltage on the output while programming the clock/timer.

### Setting the Clock/Calendar

To program the clock, hold the CLOCK/TIMER button down continuously for approximately 4 sec. The “seconds” portion of the display will begin to blink. Reset to :00 with the RESET button.

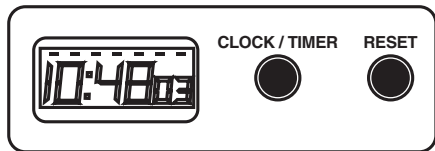

Figure 6

Push and hold or lock (clockwise turn) the PUSH-TO-TEST button. The “minutes” portion of the display will begin to blink 00:XX:00. Press the RESET button to select minutes (00-59).

To access the hour portion of the display, release the PUSH-TO-TEST button. Input the current hour using the RESET button. Hour inputs are programmed using a 12-hour format.

Push and hold the PUSH-TO-TEST button for a second time. The display switches from clock format to calendar (DD:MM). Input the current day (1-31) with the RESET button. Release the PUSH-TO-TEST to activate the “month” portion of the calendar (1-12). Input the current month using the RESET key.

Pressing the PUSH-TO-TEST button a final time causes the day segment indicator to blink (top of display). The format has seven segments indicating days of the week. Select the proper day representation with the RESET key.

Validate the choices by pressing the CLOCK/TIMER button once.

## ***Using the Timer***

The timer portion may be used in two different ways:

First, Voltage Timer indicates time elapsed since the application of the selected test voltage. The timer begins the count (to a hundredth of second) when the PUSH-TO-TEST button is pressed. Releasing the PUSH-TO-TEST button suspends the timer operation. Reapply the test voltage to start the clock again, beginning at the previously elapsed time.

Second, Discharge Timer indicates the time that elapses during the portion of the test when the test voltage has been removed.

The timer may also be controlled (start and stop) using the RESET key.

**Voltage Timer:** This mode causes the timer to begin counting whenever the test voltage is applied. Begin by toggling to the timer portion of the display using the CLOCK/TIMER button (this mode is indicated by the blinking segment(s) on the top portion of the display). Reset to 0 00 00 using the RESET key. The clock will activate each time the PUSH-TO-TEST button is depressed.

**Discharge Timer:** This mode causes the timer to begin counting when the applied test voltage has been removed (i.e., when the PUSH-TO-TEST button is out). To activate this mode, put the display into the clock mode (indicated by one stationary segment on top portion of display) and push/lock the PUSH-TO-TEST button.

With the PUSH-TO-TEST button engaged, switch the display from clock to timer and push the RESET key. The display will reset indicating 0 00 00.

**Note:** In the discharge mode (PUSH-TO-TEST button out), the meter displays the voltage at the terminals. The voltage will drop indicating discharging of the tested sample.

## **OPERATION: MODELS 5000N, 5100 & 5110**

### **The Analog Scale**

***Before taking any measurements, verify that the pointer is zeroed correctly (red AC scale "0"). If it is not, adjust with the mechanical zero adjust screw.***

The analog scale serves two functions:

First, it indicates the actual resistance of the insulating material under test (black scales). The TOP scale is used for measurement on the M $\Omega$  and G $\Omega$  ranges. The bottom half (M $\Omega$ ) covers the range of 30M $\Omega$  to 30,000M $\Omega$  (3M $\Omega$  to 30,000M $\Omega$  for Model 5110), reading from left to right. The upper half of the scale (G $\Omega$ ) covers the range of 3G $\Omega$  to 3000G $\Omega$  and reads right to left.

The center portion of the scale is used for the low insulation test range of 10k $\Omega$  to 30,000k $\Omega$ , reading from right to left.

The bottom red arc is an AC/DC voltmeter that is divided into 10 volt increments. The voltmeter function is operable any time the PUSH-TO-TEST button is out. The voltmeter detects the presence of voltage on the equipment to be tested. **(If voltage is detected, do not proceed with the insulation test).**

The voltmeter function also indicates if, after completing insulation testing, the sample under test has stored a dangerous capacitive charge. The instrument discharges this capacitance internally and the needle will drop accordingly. Disconnect the meter when the sample is discharged.



#### **Warning:**

Electrical equipment and cables may have sufficient capacitance to store a dangerous charge from the instrument test current. For proper discharge to occur the PUSH-TO-TEST button must be in the OFF position with the sample connected between the EARTH and LINE terminals.

On prolonged tests, the PUSH-TO-TEST button may be locked in the ON position; care should be taken in this mode that no damage is done if the instrument is left unattended.



## Preliminary Check

When the push-to-test button is in the OFF position, the pointer should be on zero of the voltmeter scale, and on three of the  $G\Omega$  scale. If it is not, use the mechanical zero adjust on the front of the instrument.

- Detach the leads from the instrument.
- Press the push-to-test button into the ON position. The pointer should deflect completely to the far right of the scale. The green neon "Bat." lamp should light up (Model 5000N) or the red neon light will blink (Models 5100 and 5110).

### MODEL 5000N:

Note: Ensure that the "Bat." light (green) does not go out at any point during the testing. If the light does not illuminate, stop the test and change the batteries before continuing.

### MODELS 5100 and 5110:

Note: Ensure that the "battery low" light (red) is not illuminated at any point during the testing. If the light illuminates, stop the test and charge the battery using the AC supply cord.

Verify that NO VOLTAGE is present on the circuit to be tested.

## How to Use the Push-to-Test Button

**OFF:** Push-to-test button is in the raised position. This is for measurement of AC or DC voltages (safety check). NOTE: Do not depress the push-to-test button if voltage is present.

**ON:** Push-to-test button is depressed and held down for the duration of the test. This is for insulation resistance tests.

**LOCK-ON:** Push-to-test button is depressed and turned clockwise  $90^\circ$  to lock into position. This is for insulation resistance tests of long duration such as the Time Resistance or Absorption Test.

## Utilizing the Guard Terminal

Guard terminals are useful when measuring high resistance values and for stabilizing readings.

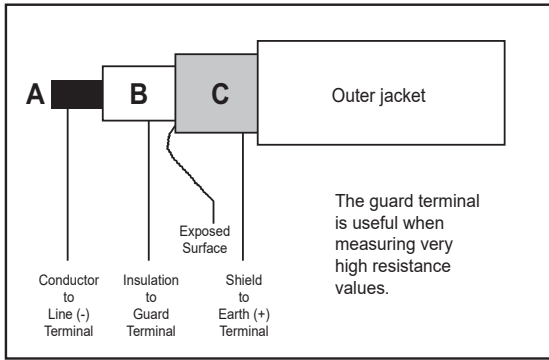

Figure 7

When testing the insulation at the end of a cable, it is necessary to eliminate the error from surface leakage that occurs, particularly at high resistance values. The guard terminal provides a third terminal within the path of the surface leakage. Connect the instrument as shown in Figure 7.

If there is no shield at "B", use a copper wire wound several times around the exposed surface "B". (**Note:** If a shield is not available and you do not make up a shield around "B" and connect to the guard terminal (-), the measurement will be erroneous and lead to confusion as to the cable's state).

If the guard terminal is not connected at "B", the instrument measures the current "I" flowing through the insulation and a surface leakage current " $i_1$ ". See Figure 8.

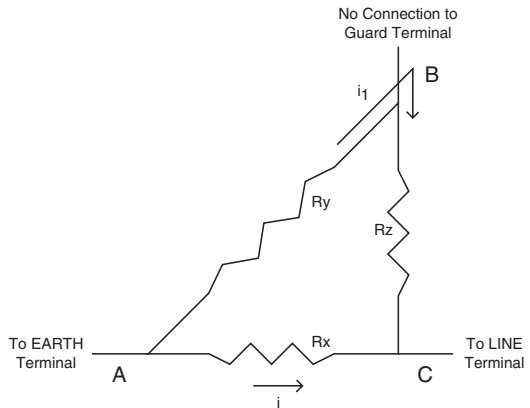

Figure 8

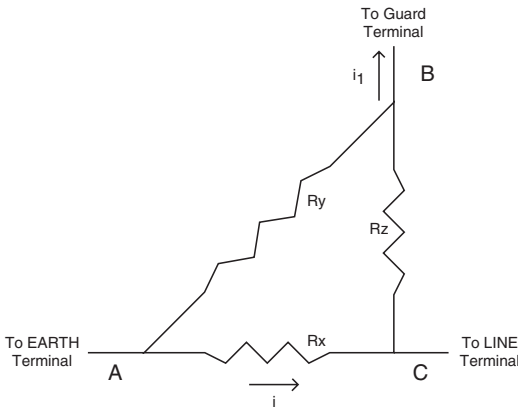

Figure 9

When the guard terminal is connected at “B”, the instrument measures the current “ $I$ ” and not the surface leakage current “ $i_1$ ”, which is not included in the measurement. See Figure 9. This type of measurement will give the true value of the resistance “ $R_x$ ”, providing the “ $R_y$ ” and “ $R_z$ ” are not too low.

## Voltage Measurements (Safety Check)

These instruments can measure AC or DC voltages. For voltage measurements, proceed as follows:

- The push-to-test button should be in the OFF position.
- Connect the instrument with the voltage leads connected between the Line (–) and Earth (+) terminals on the unit.
- Read the voltage directly on the voltage scale.

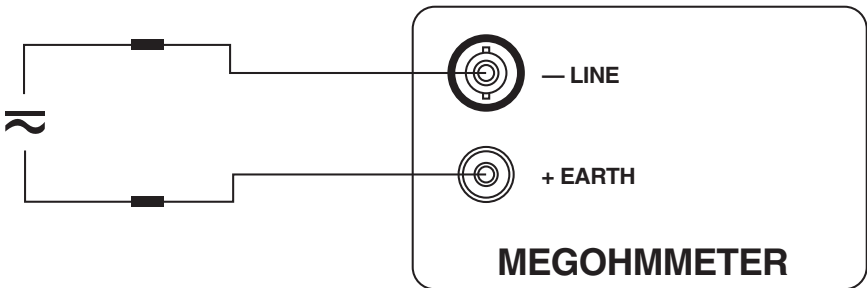

Figure 10

## Audible Signal

When the push-to-test button is in the ON or LOCK-IN position, an audible signal will result. This signal consists of approximately one beep every six seconds (ten beeps per minute). The signal can be used as a time base for monitoring the duration of the test. On the  $M\Omega$  and  $G\Omega$  ranges, the signal indicates that the instrument is in operation and that the selected DC test voltage may be present on the terminals of the instrument.

**Note:** On the Models 5100 and 5110, the audible signal may be disconnected by means of a jumper located on the main circuit board.

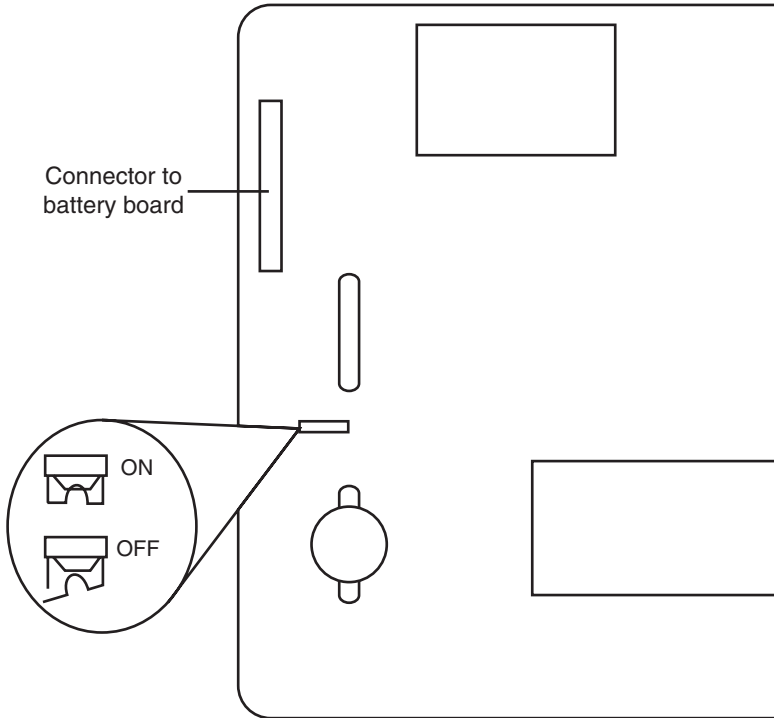

Figure 11

## Precautions When Making DC Insulation Tests

- The equipment should be taken off the line sufficiently in advance to permit it to cool to ambient temperature.
- When you are testing windings, they should be clean and dry; let solvents and cleaners evaporate. Should foreign matter or wet surfaces be present, erroneous readings may result. (A clean, dry sample's resistance will rise for 10 to 15 minutes, whereas a wet, dirty one will stabilize quickly.)
- Make sure that the equipment tested is properly discharged and grounded before testing.
- When testing individual windings, connect all other windings (not under test) together and ground to motor frame.
- When testing phases, be sure they are open to test each individually.
- After applying a test voltage, allow sufficient discharge time. As a rule, discharge twice as long as tested.

**Note:** The instrument voltmeter will indicate the discharge voltage at the terminals.

## Insulation Measurement - Connections

Figure 12 shows the connections to measure the insulation of one conductor to the other conductors. The cable should be disconnected at both ends to avoid leakage through switchboards and panels.

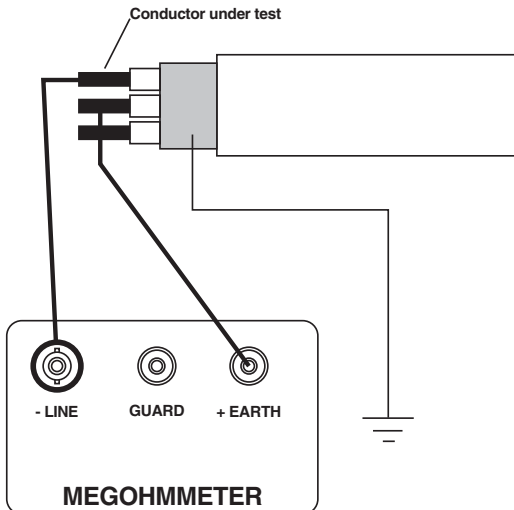

Figure 12

Figures 13 and 14 show the connection for testing insulation from a supply conductor to a ground (motor frame). The connection to the guard terminal is used to eliminate the effects of surface leakage across exposed insulation at one end of the cable. Refer to the section on Utilizing the Guard Terminal (pg 24). The cable should be disconnected at both ends to avoid leakage through switchboards and panels.

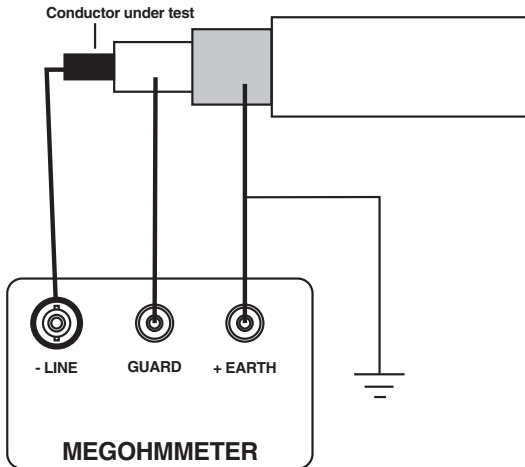

Figure 13

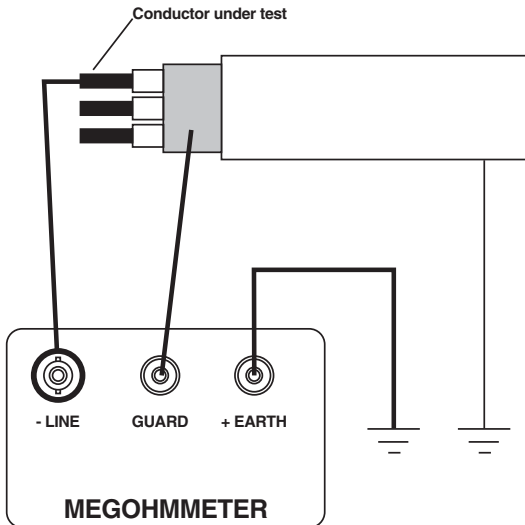

Figure 14

Figure 15 shows the connections to a transformer. Make sure that the switches and/or circuit breakers on both sides are open. Check the high voltage winding to ground, low voltage to ground, and the resistance between them with no winding grounded.

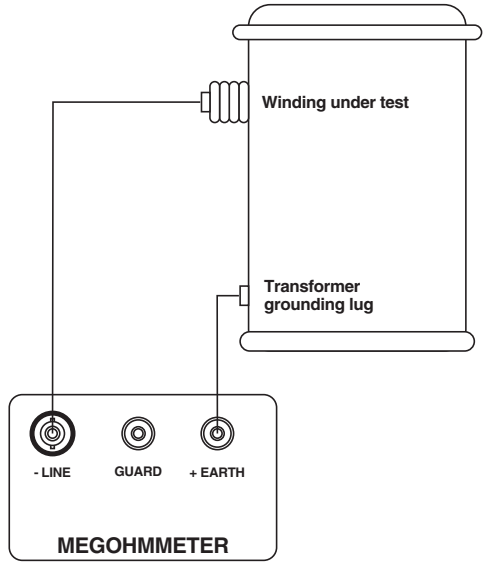

Figure 15

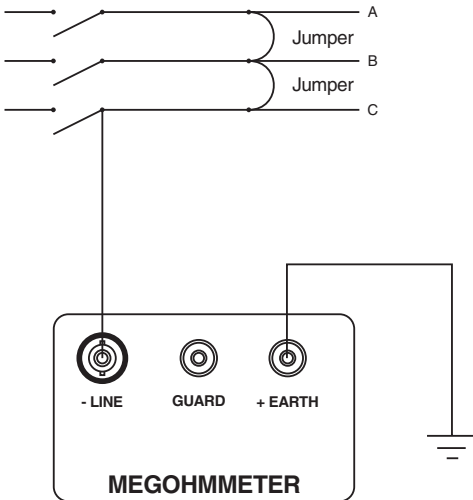

Figure 16

Figure 16 shows the connections for measuring the insulation of a three-phase line to ground by connecting the jumpers between phases. This gives a reading of all conductors at once. If a load such as a motor, heater, etc., is attached to the other end of the line, it will read the load resistance to ground at the same time. By removing the jumpers, readings can be made between the individual conductors and ground.

## Insulation Resistance Measurements on Motors

Figure 17 shows reading the resistance to ground of a three-phase motor winding. Since the three-phase motors are internally connected, it is only necessary to connect one lead to the motor lead and the other lead to the motor frame as shown.

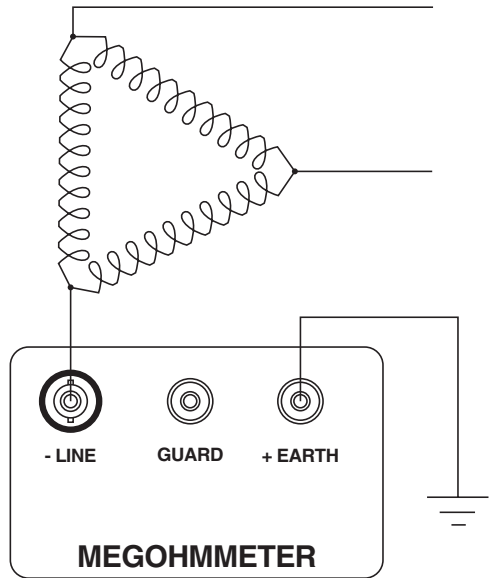

Figure 17

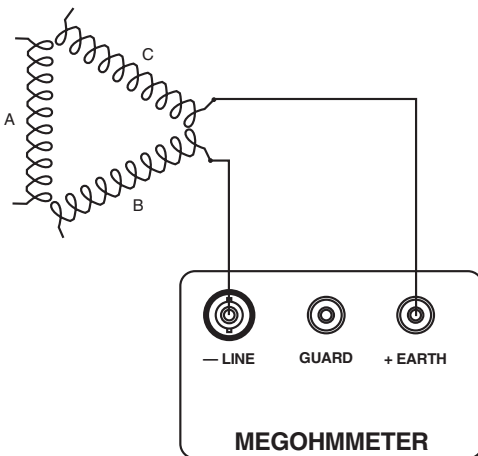

Figure 18

Figure 18 shows the windings of a three-phase motor separated. Sometimes this can be done at the lead terminals while other times the end bells must be removed to get at the lead wires of the coils. By connecting the megohmmeter as shown, the phase insulation resistance value can now be determined. Read between phases "A" and "B", then "B" and "C", then "C" and "A".



Figure 19 shows connections for testing insulation from a supply conductor in a switchbox to ground (motor frame). An identical test may be carried out from the motor starter.

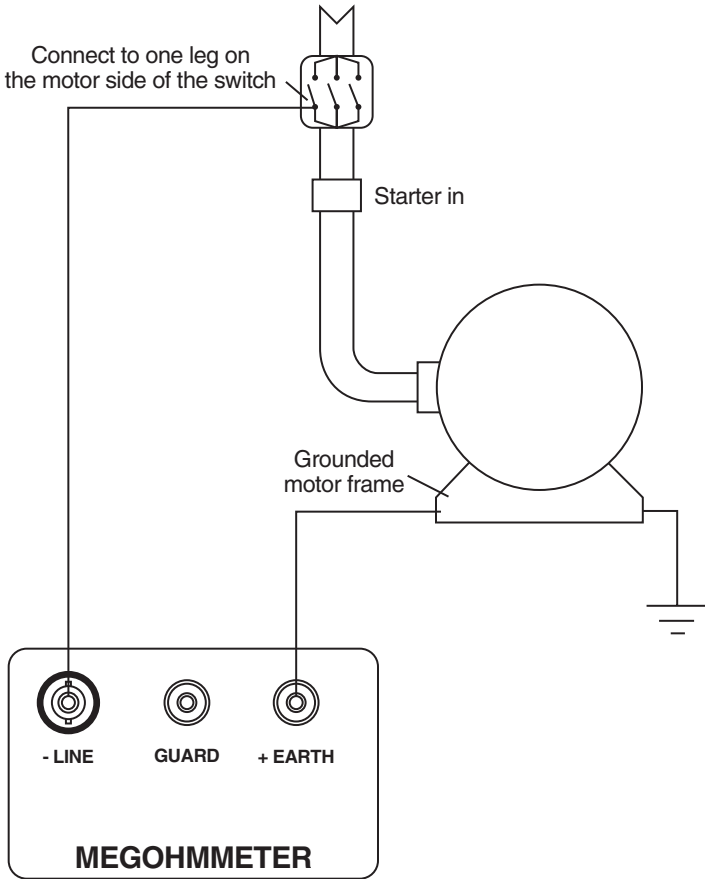

Figure 19

## **UNDERSTANDING INSULATION TESTING**

Insulation is the material between two points of different potential which, through high resistivity, prevents the flow of current between those points. Insulation failure is one of the most common problems associated with electrical equipment breakdown.

A megohmmeter is an insulation resistance tester which is essentially a high resistance ohmmeter ( $M\Omega$  or greater) providing a high DC potential (up to 5000V). This high potential causes low amounts of current to flow through and over the insulation which is under test.

Many factors can cause insulation to fail: mechanical damage, moisture, heat, foreign debris, corrosion, etc. As time passes, these factors combine to permit excessive current to flow through insulation at points where it would normally be blocked by the insulation resistance. Usually, the resistance on degrading insulation will drop gradually, providing plenty of warning. Other times it will drop suddenly, as when it is immersed.

With periodic resistance tests and good record keeping, it is possible to get an accurate picture of the insulation condition. Insulation resistance testing is intended to indicate not only if equipment is bad, but also whether it is becoming bad.

Resistance of many types of insulation can vary greatly with temperature. The resistance data obtained should be corrected to the standard temperature for the class of equipment under test.

Please note that although we present information on test procedures, values and recommended frequency of testing, the manufacturer of your particular piece of equipment is the definitive source for testing parameters and procedures. While we refer to commonly applied rules and practices, every test will not be practical to each piece of electrical equipment in your facility.

## **RATIO TESTING**

In time resistance reading (dielectric absorption ratio), readings are taken at 30 seconds and 60 seconds to obtain the dielectric absorption ratio.

$$\frac{\text{Insulation resistance @ 60s}}{\text{Insulation resistance @ 30s}} = \text{Dielectric Absorption Ratio (DAR)}$$

This test is useful for increasing the accuracy of spot testing. In general, a ratio of 1.25 to 2 or better should be required. (Below 1.1 is dangerous; 1.1 to 1.25 is questionable; 1.25 to 1.4 is fair; and 1.4 to 2 and above is good.) A ratio below this indicates that repair is probably needed.

Remember that a DC insulation test may be used for acceptance testing, but is more commonly used to check the gradual deterioration of equipment over its lifetime. Consult your equipment manufacturer for specific test or test voltage if not known.

Insulation resistance decreases with moisture, temperature and age, and should be recorded over time at a given temperature and corrected.

## **TYPES OF TESTS**

### **Spot Reading Test**

#### ***Method***

For this test, the megohmmeter is connected across the insulation of the windings of the machine being tested. A test voltage is applied for a fixed period of time, usually 60 seconds, and a reading is taken. The spot reading test should only be carried out when the winding temperature is above the dewpoint<sup>1</sup>. The operator should note the winding temperature so that the reading may be corrected to a base temperature of 20°C (68°F).

#### ***Test Duration***

To obtain comparable results, tests must be of the same duration. Usually the reading is taken after 60 seconds.

#### ***Interpreting the Results***

Proper interpretation of spot reading tests requires access to records of results from previous spot reading tests. For conclusive results, only use results from tests performed at the same test voltage for the same amount of time under similar temperature and humidity conditions. These readings are used to plot a curve of the history of insulation resistance. A curve showing a downward trend usually indicates a loss of insulation resistance due to unfavorable conditions such as humidity, dust accumulation, etc. A very sharp drop indicates an insulation failure.

---

<sup>1</sup> Dewpoint temperature is the temperature at which the moisture vapor in the air condenses as a liquid.

## Polarization Index

### ***Method***

This test is based on the comparison of absorption characteristics of good insulation vs. the absorption characteristics of humid or otherwise contaminated insulation. During the test, a test voltage is applied for an extended period, usually 10 minutes. The operator takes a reading every 10 seconds for the first minute, and then every minute up to 10 minutes. A curve is drawn showing the insulation resistance value versus time.

### ***Test Duration***

10 minutes

### ***Interpreting the Results***

If the results were plotted on a graph, the slope of the curve would indicate the condition of the insulation under test. A good insulation will show a continual increase in resistance for typically 10 to 15 minutes. Contaminated, moist, or cracked insulation will produce a relatively flat curve.

A ratio known as the **polarization index** can be obtained by dividing the value from the 10-minute reading by the value from the one-minute reading. This polarization index is indicative of the slope of the curve.

A low polarization index usually indicates excessive moisture and contamination. On large motors or generators, values as high as 10 are commonly expected.

$$\text{Polarization index} = \frac{\text{10-minute reading}}{\text{1-minute reading}}$$

The IEEE Std 43-1974<sup>2</sup> lists the following minimum values for the polarization index for AC and DC rotating machines:

Class A: 1.5

Class B: 2.0

Class C: 2.0

---

<sup>2</sup> IEEE Std. 43-1974, - *Recommended Practice for Testing Insulation Resistance of Rotating Machinery*

## **Step Voltage Test**

### ***Method***

In this test, the operator applies two or more test voltages in steps. The recommended ratio for the test voltage steps is 1 to 5. At each step, test voltage should be applied for the same length of time, usually 60 seconds. The application of increased voltage creates electrical stresses on internal insulation cracks. This can reveal aging and physical damage, even in relatively dry and clean insulation, which would not have been apparent at lower voltages.

### ***Test Duration***

A series of “steps,” each step lasting 60 seconds.

### ***Interpreting the Results***

Compare the readings taken at different voltage levels, looking for any excessive reduction in insulation resistance values at the higher voltage levels. Insulation that is thoroughly dry, clean, and without physical damage should provide roughly the same resistance values despite changes in test voltage levels. If resistance values decrease substantially when tested at higher voltage levels, this should serve as a warning that insulation quality may be deteriorating due to dirt, moisture, cracking, aging, etc.

## **THE EFFECTS OF TEMPERATURE**

Insulation resistance measurements are changed by variations in temperature of the insulation material. Typically, when the temperature goes up, the insulation resistance will go down. Inversely, when the temperature drops the insulation resistance will increase in value.

The best way to obtain consistent measurement results is to test the insulation at a standard temperature, typically 68°F (20°C). If the temperature of the material you are testing is either higher or lower than 68°F (20°C), refer to the temperature correction chart (see table). As a general rule the insulation resistance value may be corrected by:

- Halving the resistance measurement value for every 10°C above the base temperature of 68°F (20°C), or
- Doubling the resistance value for every 10°C below 68°F (20°C)

°C	°F	Multiplication Factor
0	32	0.25
5	41	0.36
10	50	0.50
15	59	0.75
20	68	1.00
25	77	1.40
30	86	1.98
35	95	2.80
40	104	3.95
45	113	5.60
50	122	7.85
55	131	11.20
60	140	15.85
65	149	22.40
70	158	31.75
75	167	44.70
80	176	63.50

## **INTERPRETING THE RESULTS**

Insulation resistance values are a function of the type of insulating material. The actual value you read may vary greatly and is not as important as the trends of the values over time. This is why the resistance measurement must be taken in a greater context. Some other factors to consider are:

### ***Previous Testing Results***

These are very important, since they will indicate the decline in the insulation resistance over time. All new equipment should be tested and documented to serve as a benchmark for future testing.

### ***Careful Visual Inspection***

By taking a very close look at the equipment you are testing it may be possible to see cracks, excessive moisture, burn marks, etc., which may, over time, cause catastrophic equipment failure.

### ***Manufacturers' Recommendations for Specific Equipment***

The definitive source for information on a specific piece of equipment is its manufacturer. Most manufacturers will provide basic information about the insulation resistance which may be encountered during testing.

### ***Comparisons with Similar Equipment***

Similar equipment should provide similar insulation resistance values. This would also remain true when testing cables. For three-phase systems, it would be very useful to compare resistive values between the phases.

By performing insulation resistance tests regularly and recording the test results, it may be possible to predict failure by detecting a downward trend in the resistance. Careful notations should be made as to time/date, temperature, applications, etc.

The information contained in this manual is intended only as a guide to acceptable procedure; it is not intended to be used as a test specification for specific electrical equipment.



## **MAINTENANCE**



### **Warning:**

- For maintenance use only original factory replacement parts.
- To avoid electrical shock, do not attempt to perform any servicing unless you are qualified to do so.
- Do not perform any service while the Megohmmeter is on any circuit.
- To avoid electrical shock and/or damage to the instrument, do not get water or other foreign agents into the electronic module.

### **Cleaning**

The megohmmeter may be gently cleaned with a soft cloth, soap and water. Dry immediately after cleaning. Avoid water penetration into the electronic module.

Make sure the megohmmeter and all leads are dry before further use.

## Repair and Calibration

To ensure that your instrument meets factory specifications, we recommend that it be submitted to our factory Service Center at one-year intervals for recalibration, or as required by other standards or internal procedures.

### **For instrument repair and calibration:**

You must contact our Service Center for a Customer Service Authorization number (CSA#). This will ensure that when your instrument arrives, it will be tracked and processed promptly. Please write the CSA number on the outside of the shipping container. If the instrument is returned for calibration, we need to know if you want a standard calibration, or a calibration traceable to N.I.S.T. (Includes Calibration Certificate plus recorded calibration data).

Chauvin Arnoux<sup>®</sup>, Inc.  
d.b.a. AEMC<sup>®</sup> Instruments  
15 Faraday Drive  
Dover, NH 03820 USA

Tel: (800) 945-2362 (Ext. 360)  
(603) 749-6434 (Ext. 360)  
Fax: (603) 742-2346 or (603) 749-6309

(Or contact your authorized distributor)

Costs for repair, standard calibration, and calibration traceable to N.I.S.T. are available.

**Note: You must obtain a CSA# before returning any instrument.**

## Technical and Sales Assistance

If you are experiencing any technical problems, or require any assistance with the proper operation or application of your instrument, please call, fax or e-mail our technical support hotline:

Chauvin Arnoux<sup>®</sup>, Inc.  
d.b.a. AEMC<sup>®</sup> Instruments  
Phone: (800) 945-2362 (Ext. 351)  
(603) 749-6434 (Ext. 351)  
Fax: (603) 742-2346  
E-mail: [techsupport@aemc.com](mailto:techsupport@aemc.com)



Chauvin Arnoux<sup>®</sup>, Inc. d.b.a AEMC<sup>®</sup> Instruments  
15 Faraday Drive • Dover, NH 03820, USA  
[www.aemc.com](http://www.aemc.com)