

Micro-Ohmmeter Model 5600

USER MANUAL

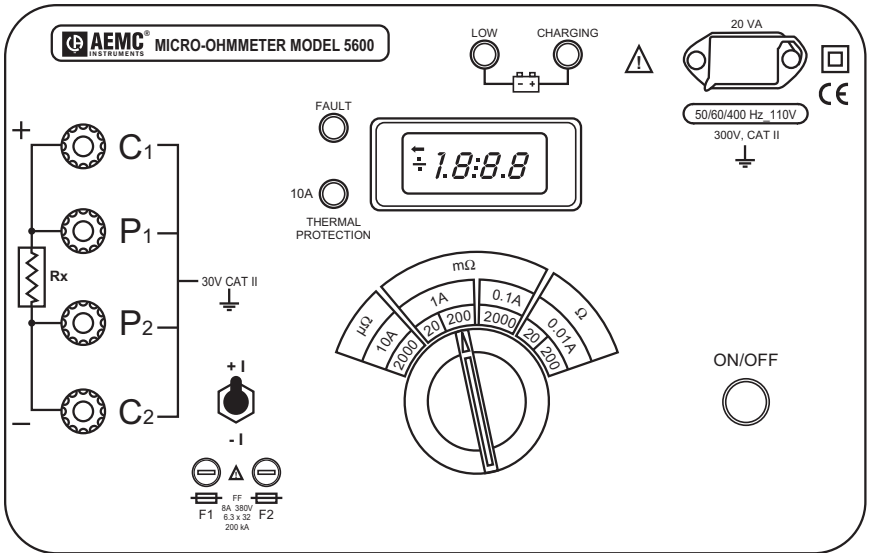

Limited Warranty

The Model 5600 is warranted to the owner for a period of 2 years from the date of original purchase against defects in manufacture. This limited warranty is given by AEMC® Instruments, not by the distributor from whom it was purchased. This warranty is void if the unit has been tampered with, abused or if the defect is related to service not performed by AEMC® Instruments.

For full and detailed warranty coverage, please read the Warranty Coverage Information, which is attached to the Warranty Registration Card (if enclosed) or is available at www.aemc.com. Please keep the Warranty Coverage Information with your records.

What AEMC® Instruments will do:

If a malfunction occurs within the warranty period, you may return the instrument to us for repair, provided we have your warranty registration information on file or a proof of purchase. AEMC® Instruments will, at its option, repair or replace the faulty material.

YOU CAN NOW REGISTER ONLINE AT:
www.aemc.com

Warranty Repairs

What you must do to return an Instrument for Warranty Repair:

First, request a Customer Service Authorization Number (CSA#) by phone or by fax from our Service Department (see address below), then return the instrument along with the signed CSA Form. Please write the CSA# on the outside of the shipping container. Return the instrument, postage or shipment pre-paid to:

Chauvin Arnoux®, Inc. d.b.a. AEMC® Instruments
15 Faraday Drive • Dover, NH 03820 USA
Tel: (800) 945-2362 (Ext. 360)
(603) 749-6434 (Ext. 360)
Fax: (603) 742-2346 or (603) 749-6309
repair@aemc.com

Caution: To protect yourself against in-transit loss, we recommend you insure your returned material.

NOTE: All customers must obtain a CSA# before returning any instrument.

Table of Contents

Warning	3
International Electrical Symbols	3
Definition of Measurement Categories	3
Receiving Your Shipment.....	4
Packaging.....	4
Accessories and Replacement Parts	4
Description	4
Electrical Specifications	5
Mechanical Specifications	6
Safety Specifications.....	6
Control & Connector Identification	7
Disassembly	8
AC Power Selection	9
Indicators.....	10
Battery Indicators.....	10
Display Indicators	10
Fault Indicators	11
Operating Procedure.....	12
Connections and Reading	12
Very Low Resistance.....	13
Meter Readings	13
Application Examples.....	14
Measuring Winding Resistance of Motors and Transformers	14
Measuring Resistance on Electric Motors	15
Battery Strap Measurements.....	16
Maintenance.....	17
Warning	17
Cleaning.....	17
Repair and Calibration	18
Technical and Sales Assistance	18



- These safety warnings are provided to ensure the safety of personnel and proper operation of the instrument.
- Do not attempt to perform any tests with this instrument until you have read the instruction manual.
- Tests are to be carried out on non-live and de-energized circuits only!
- The micro-ohmmeter should never be used in an explosive environment (this includes poorly ventilated battery rooms and enclosures).
- Make sure the internal battery is fully charged prior to testing. If the instrument has been unused for several months, recharge the battery.
- We recommend recharging the micro-ohmmeter every month to ensure a full battery charge when used.
- Only install fuses which are direct replacements.
- If the case needs cleaning, do not use any alcohol or oil based cleaners. Preferably use soapy water with a damp cloth or sponge.

International Electrical Symbols



This symbol signifies that the instrument is protected by double or reinforced insulation. Use only specified replacement parts when servicing the instrument.



This symbol signifies CAUTION! and requests that the user refer to the user manual before using the instrument.



Risk of electric shock. The voltage at the parts marked with this symbol may be dangerous.

Definition of Measurement Categories

- Cat. IV:** For measurements performed at the primary electrical supply (<1000V) such as on primary overcurrent protection devices, ripple control units, or meters.
- Cat. III:** For measurements performed in the building installation at the distribution level such as on hardwired equipment in fixed installation and circuit breakers.
- Cat. II:** For measurements performed on circuits directly connected to the electrical distribution system. Examples are measurements on household appliances or portable tools.

Receiving Your Shipment

Upon receiving your shipment, be sure that the contents are consistent with the packing list. Notify your distributor of any missing items. If the equipment appears to be damaged, file a claim immediately with the carrier and notify your distributor with a detailed description of any damage. Save the damaged packing container to substantiate your claim.

Packaging

The Model 5600 Micro-Ohmmeter (Cat. #1431.01) is supplied with a power supply lead, hex wrench, and user manual.

Accessories and Replacement Parts

Kelvin probes, set of two, on 10 ft color-coded leads with banana plug terminations.....	Cat. #1017.82
Kelvin clips, 1A, set of two, on 10 ft color-coded leads with banana plug terminations	Cat. #1017.83
Kelvin clips, 10A, set of two, on 10 ft color-coded leads with spade lug terminations.....	Cat. #1017.84
Fuse, set of 10, 8A, 1¼ x 1/4" fast blow.....	Cat. #2970.13
Battery 6V, 7 Ah rechargeable NiCad.....	Cat. #2960.12
Soft carrying bag for accessories.....	Cat. #2119.83
Kelvin Probes 20 ft spring loaded	Cat. #2118.52

Description

The Model 5600 performs reliable low resistance measurements with test currents to 10A and resolution to one micro-ohm.

The front end of the Model 5600 employs a four-wire Kelvin configuration, which eliminates test lead resistance for a measurement accuracy of 0.25%. A reverse polarity switch compensates for the effect of DC voltage interference on the accuracy and permits reading averaging. A built-in circuit filters against AC signals.

The Micro-Ohmmeter Model 5600 is housed in a sealed field case. Power is supplied by a long-life NiCad battery with a built-in recharger (110/220V). The large, easy-to-read LCD is 18mm high; it displays the value of resistance, and indicates overrange and reversed connection of measurement leads.

Four LEDs on the front panel indicate measurement faults (open circuit, blown fuse, etc.); thermal protection; low battery and battery recharging.

For operator safety and instrument protection, the micro-ohmmeter is fuse protected at the inputs. Two fuses, accessible on the front panel, protect against stored energy in inductive loads.

Enhanced internal circuitry protects against possible inductive kickback when the current is shut off. A built-in thermal switch protects the micro-ohmmeter against overheating on the 10A range when in continuous use.

Electrical Specifications

Specifications are given for an ambient temperature of $23^{\circ}\text{C} \pm 3^{\circ}$, relative humidity of 40 to 60% and a supply voltage of $6\text{V} \pm 0.1\text{V}$.

Ranges	2000 $\mu\Omega$	20m Ω	200m Ω	2000m Ω	20 Ω	200 Ω
Display	1999	19.99	199.9	1999	19.99	199.9
Resolution	1 $\mu\Omega$	10 $\mu\Omega$	100 $\mu\Omega$	1m Ω	10m Ω	100m Ω
Test Current	10A	1A	1A	100mA	10mA	10mA

Accuracy:

2000 $\mu\Omega$ range:

0.25% of Reading typical, 0.5% max \pm 2cts

20, 200, 2000m Ω , 20, 200 Ω ranges:

0.25% of Reading typical, 0.5% max \pm 1ct

Influence of Environment Conditions:

Temperature: 0.1% per 10°C typical, 0.25% max.

Humidity: 0.5% max from 10 to 90%

Battery Voltage: \pm 0.1% from 4.5 to 7V

Power Supply:

Rechargeable 6V, 7 Ah NiCad battery;

Built-in 110/220V (47 to 450Hz) charger;

Automatic shutoff after 4 minutes non-use;

Automatic shutoff when battery voltage $<4.5\text{V}$

Battery Life (Typical):

2000 $\mu\Omega$ range: 200 to 300 8-second measurements

20-200m Ω ranges: 900 30-second measurements (approx)

2000m Ω , 20-200 Ω ranges: 5000 30-second measurements (approx)

Operating Voltage: 4.5 to 7VDC

Recharge Time: 14 hours from full discharge (approx)

Mechanical Specifications

Display: 2000ct, 7 segment LED

Case: Fiberglass-charged polycarbonate, with handle and removable lid, watertight to IP534 (lid closed), IP520 (lid open).

Color: Safety yellow case with gray faceplate

Operating Temperature: 14° to 131°F (-10° to 55°C)

Storage Temperature: -4° to 131°F (-20°C to 55°C)

Dimensions: 15.35 x 10.24 x 9.84" (390 x 260 x 250mm)

Weight: 17 lbs 10 oz (8kg approx) without leads

Safety Specifications

Safety Standards:

Electrical: EN 61010, 300V, Cat. III



Electromagnetic:

IEC 801-2, Electrostatic discharge

IEC 801-3, Electromagnetic Fields

IEC 801-5, Electrical shocks

Mechanical/environmental:

IEC 529, Protection Index (IP)

IEC 68.2.6, Vibrations

IEC 68.2.27, Shocks

IEC 68.2.29, Shake

IEC 68.2.31, Knock over

IEC 68.2.32, Drop test

Case Material: UL 94

Overload Input Protection: 380Vrms

Fuses: Two high interrupting capacity, 8A, 380V, 1¼ x ¼"

Control & Connector Identification

1. Lead connection terminal lugs; accepts 4mm diameter banana jack or 6mm (min) spade lugs.
2. Thermal protection indicator
3. Measurement current fault indicator
4. Liquid crystal display
5. Battery indication lights (low battery & charging)
6. Line cord input socket for battery recharging
7. On/Off power button
8. Six-position rotary switch selects measurement range & output current
9. Polarity inverter switch
10. Input fuse holders

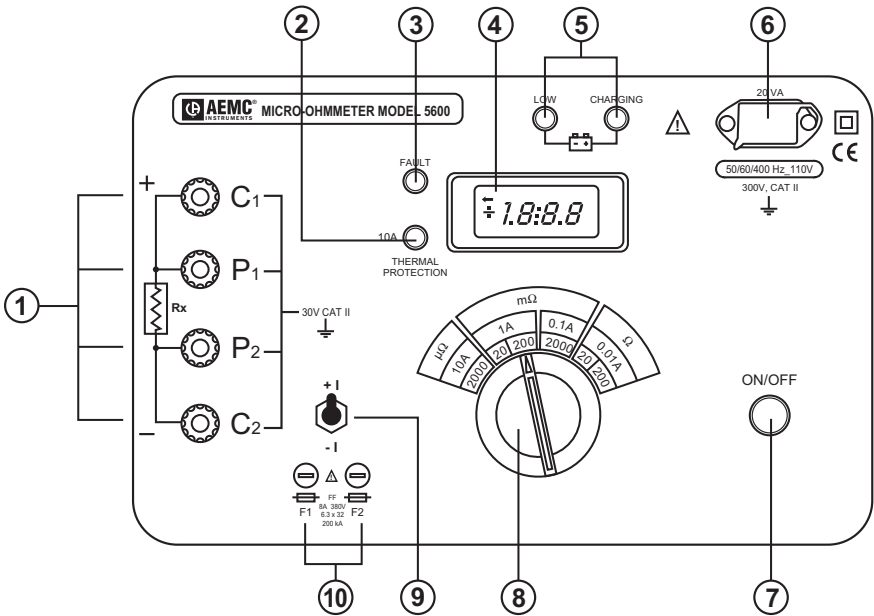

Figure 1

Disassembly

Before replacing the internal batteries or changing the power supply voltage rating, the chassis must first be removed. Use the hex key to unscrew the six fastening screws from the chassis, which are located on the bottom of the case.

Pull out the chassis. Do not forget to unplug the two leads that connect the power supply board in the bottom of the case to the boards, which are mounted in the chassis. Be sure to note the polarity when reconnecting the leads.

Detachable Cover

The cover hinges are fitted with spring-loaded clips, which allow the cover to be removed. To detach the cover from the Model 5600, open the lid to a horizontal position and apply downward pressure to the hinge side of the cover while gripping it firmly (see Fig. 2).

To re-attach the cover, position the cover in a horizontal position and fit the hinges into the respective housing. Apply strong rear-to-front pressure to the cover until it snaps into place.

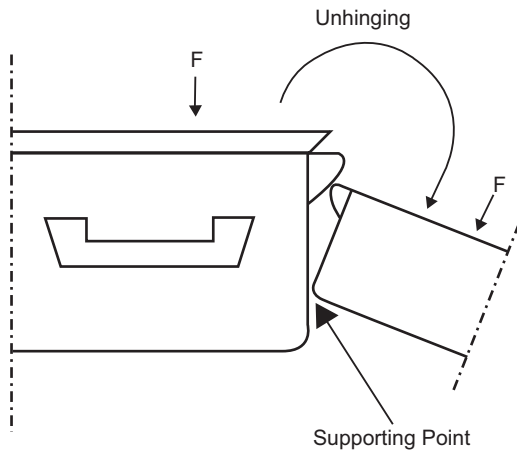

Figure 2

AC Power Selection

The Model 5600 may be recharged by 110V or 220VAC (47 to 450Hz). The instrument includes a 110V supply cord, which provides the charging voltage for the rechargeable battery. Verify that "110V" appears on the indicator located below the line cord indicator socket on the front panel; this will permit recharging with the 110V supply cord.

To change the charging voltage, disassemble the unit as previously noted. Move the switch on the power supply board to the "220V" position (see Fig. 3). A 220V supply cord (not supplied) is required for 220V operation. Be sure to change the indicator on the front panel to the "220V" position by removing the two screws that secure it and turning the indicator over.

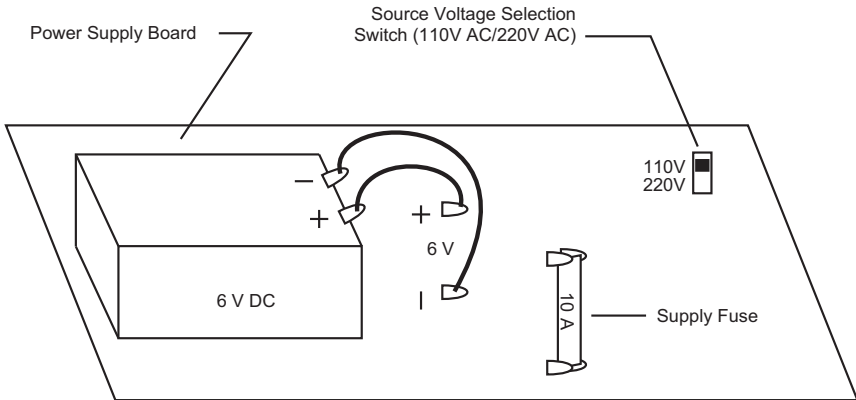

Figure 3



CAUTION: Do not change the charging voltage while the Model 5600 is connected to the AC supply.

Indicators

Battery Indicators

- **LOW** - When flashing, indicates battery life is sufficient for 10 measurements at 10A and more than 100 measurements for other test currents. When the flashing stops, the instrument no longer has sufficient power to perform any further tests. Recharge the batteries.
- **CHARGING** - The green charging light indicates that the battery is currently being recharged. This indicating light will remain on as long as the instrument is connected to AC supply.

Display Indicators

- “1” - On the left of the display indicates range overload.
- “—” - On the left of the display indicates a reversed connection of the measurement leads (crossing the voltage and current leads).

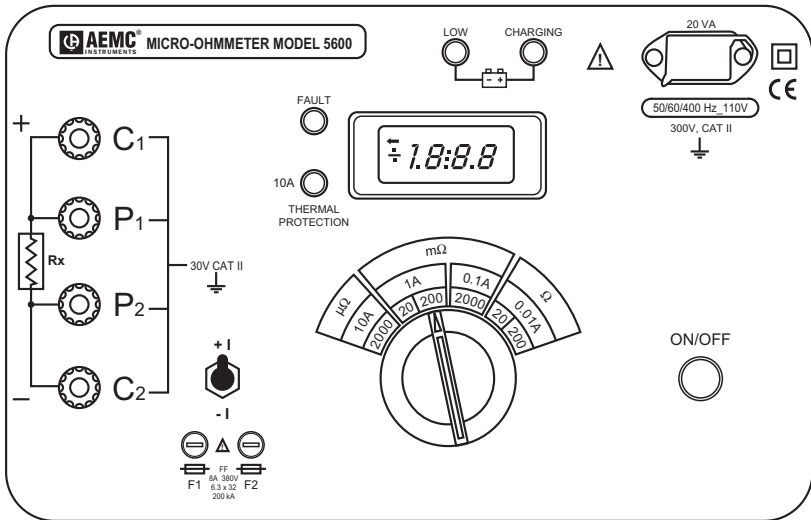

Figure 4

Fault Indicators

- **FAULT** - The fault light will illuminate in one of two cases:
 1. If the measured resistance is very high in relation to the range. Switching to a higher range will extinguish the light.
 2. If the current output is zero, due to an open circuit or blown fuse. Check the circuit for probe/clip contact on test sample and condition of fuses.
- **THERMAL PROTECTION** - On the $2000\mu\Omega$ range (10A), thermal protection of the instrument is provided by an internal thermostat which interrupts the 10A current during prolonged operation. When overheated, the thermal protection circuit turns on its respective indicator light and disables the 10A, $2000\mu\Omega$ range. The other ranges may still be used during this condition.

NOTE: To make a rapid test of the internal fuses, short-circuit terminals C1 and C2. Switch on the instrument using the On/Off button. If the "Fault" light comes on, at least one of the two fuses is blown.



When using 20 ft spring loaded Kelvin lead (Cat.# 2118.52) on the 10A range, the fault light may stay on all the time. Measured values are good.

Operating Procedure

Before performing the resistance test, verify that the sample under test is not energized.

Connections and Reading

Clean all surfaces before connecting test leads. Verify a solid connection between test leads and the sample. Set the On/Off button to the ON position and select the range that provides the most stable reading. If the anticipated resistance is not known, begin with the highest range (200 Ω) and successively lower the range selection until adequate resolution is achieved. The range selection may be changed while the instrument remains energized.

Read the displayed resistance value directly. The use of a Kelvin connection eliminates test lead resistance, as shown in Figure 5.

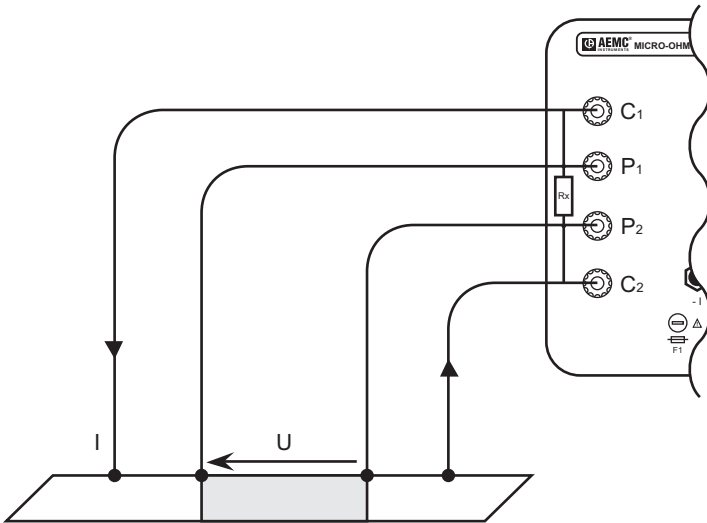

Figure 5

Very Low Resistance

When measuring very low resistive values ($2000\mu\Omega$ range) the presence of stray DC currents may affect the accuracy of the measurements. These currents can be present due to a variety of reasons including chemical or thermal EMF in samples made of dissimilar metals. You can eliminate the effects of this by reversing the direction of current flow (inverter switch, see Figure 6) and using the average of forward and reverse readings. A minus sign will appear in the display when the switch is in the reverse position. Disregard this sign when calculating the average values.

The presence of AC interference in the sample under test may cause the measured value on the display to fluctuate. This interference may become more noticeable in the presence of strong electric fields. The effects of this interference may be reduced by twisting the leads together.

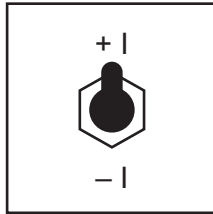

Figure 6

Meter Readings

When testing resistive samples, the meter reading will stabilize within the first few seconds. On inductive loads (e.g. transformers), the measurement reading may take from several seconds to a few minutes to stabilize and depends greatly on the type of equipment and the impedance of the equipment under test. On very large samples such as utility transformers, 10 to 15 minutes charging time may be necessary.

Application Examples

The Model 5600 performs reliably on a variety of low resistance situations. Typical applications include:

- Contact resistance of breakers and switches
- Wire to terminal connections
- Winding resistance
- Motors and generators
- Aircraft and rail bonds
- Grounding connections
- Many other very low resistance samples

The proper procedures for using the Model 5600 in some specific applications are outlined below.

Measuring Winding Resistance of Motors and Transformers

⚠ CAUTION: Prior to and after testing a transformer winding, the energy stored in the magnetic field must be dissipated by shorting the transformer terminals. For additional safety, the transformer terminals should be jumpered together before the instrument is disconnected.

One terminal of the sample should be grounded for safety!

Make connections to the transformer as shown in Figure 7. On larger transformers, the measurement stabilization time will increase.

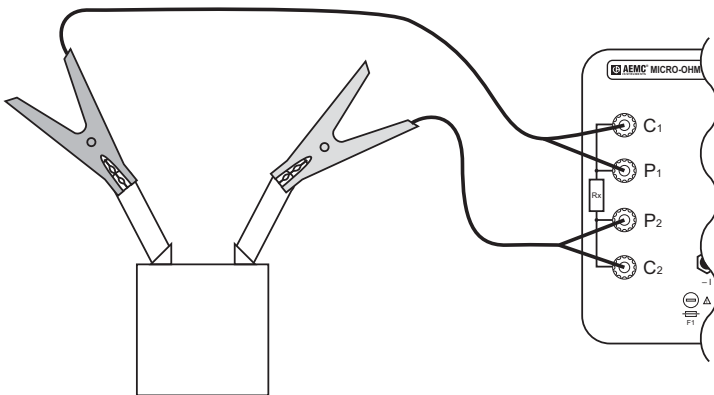

Figure 7

Measuring Resistance on Electric Motors

For this test, Kelvin probes should be used (Figure 8). Make contact with each segment on the motor commutator. Allow approximately two seconds for the display to stabilize.

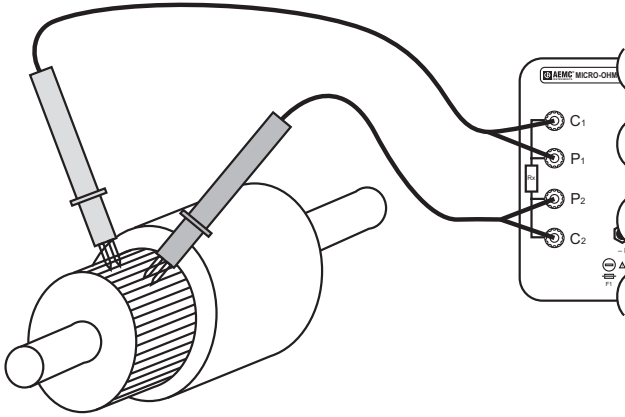

Figure 8

Battery Strap Measurements

Proper battery strap resistance measurements will help ensure proper voltage output. The resistance on battery strap connections should be measured using the Kelvin probes (see Figure 9). Measurements must be made with the system power turned off.

The average resistance of all the intercell connections should be determined by totaling the individual resistances and dividing by the number of connectors. Each individual cell resistance should not exceed the average by more than 10%. See the manufacturer's specifications for typical resistance values.

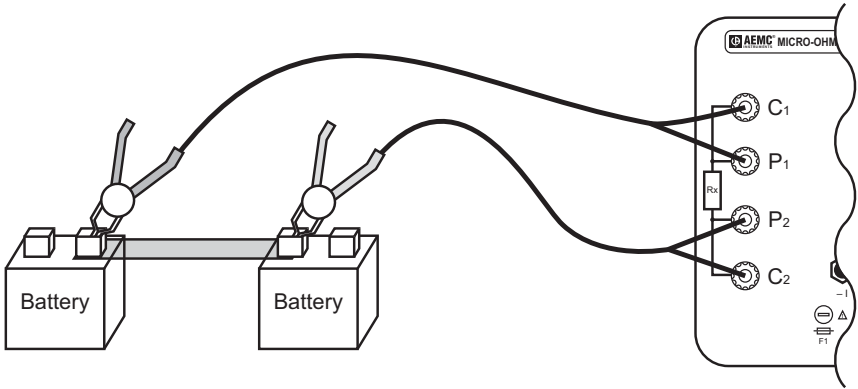

Figure 9

Maintenance



Warning:

- For maintenance use only original factory replacement parts.
- To avoid electrical shock, do not attempt to perform any servicing unless you are qualified to do so.
- Do not perform any service while the micro-ohmmeter is on any circuit.
- To avoid electrical shock and/or damage to the instrument, do not get water or other foreign agents into the electronic module.
- Make sure the internal battery is fully charged prior to testing. If the instrument has been left unused for several months, recharge the battery.
- We recommend recharging the micro-ohmmeter every month to ensure a full battery charge when used.
- When replacing fuses, install only fuses which are direct replacements.

Cleaning

- If the case needs cleaning, do not use any alcohol or oil based cleaners. Preferably use soapy water with a damp cloth or sponge.
- Dry immediately after cleaning. Avoid water penetration into the electronic module.
- Make sure the micro-ohmmeter and all leads are dry before further use.

Repair and Calibration

To ensure that your instrument meets factory specifications, we recommend that it be submitted to our factory Service Center at one-year intervals for recalibration, or as required by other standards or internal procedures.

For instrument repair and calibration:

You must contact our Service Center for a Customer Service Authorization number (CSA#). This will ensure that when your instrument arrives, it will be tracked and processed promptly. Please write the CSA# on the outside of the shipping container. If the instrument is returned for calibration, we need to know if you want a standard calibration, or a calibration traceable to N.I.S.T. (includes calibration certificate plus recorded calibration data).

Chauvin Arnoux[®], Inc.
d.b.a. AEMC[®] Instruments
15 Faraday Drive
Dover, NH 03820 USA
Tel: (800) 945-2362 (Ext. 360)
(603) 749-6434 (Ext. 360)
Fax: (603) 742-2346 or (603) 749-6309
repair@aemc.com

(Or contact your authorized distributor)

Costs for repair, standard calibration, and calibration traceable to N.I.S.T. are available.

NOTE: All customers must obtain a CSA# before returning any instrument.

Technical and Sales Assistance

If you are experiencing any technical problems, or require any assistance with the proper operation or application of your instrument, please call, fax or e-mail our technical support hotline:

Chauvin Arnoux[®], Inc.
d.b.a. AEMC[®] Instruments
Phone: (800) 945-2362 (Ext. 351)
(603) 749-6434 (Ext. 351)
Fax: (603) 742-2346
techsupport@aemc.com



Chauvin Arnoux[®], Inc. d.b.a AEMC[®] Instruments
15 Faraday Drive • Dover, NH 03820 USA
www.aemc.com